



Simon Ganahl
Campus Medius
Digital Mapping
in Cultural and
Media Studies

[transcript] <digital humanities>

Abstract

Campus Medius explores and expands the possibilities of digital cartography in cultural and media studies. Simon Ganahl documents the development of the project from a historical case study to a mapping platform. Based on the question of what a media experience is, the concepts of the apparatus (*dispositif*) and the actor-network are translated into a data model. A time-space of twenty-four hours in Vienna in May 1933, marked by a so-called “Turks Deliverance Celebration” (*Türkenbefreiungsfeier*), serves as an empirical laboratory. This Austrofascist rally is mapped from multiple perspectives and woven into media-historical networks, spanning from the seventeenth century up to the present day.

Keywords

digital mapping, cartography, mediality, media experience, Vienna, 1933, Austrofascism, Turks Deliverance Celebration, *dispositif*, actor-network

Author

Simon Ganahl (Mag. DDr. phil.), born in 1981, researches and teaches at the University of Vienna as a literature and media scholar with a focus on digital humanities. He directs the digital mapping project *Campus Medius* and edits the peer-reviewed, open-access journal *Genealogy+Critique*. After studies in Vienna, Hamburg, and Zurich, he obtained PhD degrees both in communication science and in German philology at the University of Vienna. He was a visiting researcher in the School of Media Studies at The New School in New York and a visiting lecturer in the Center for Digital Humanities at UCLA. His research work has received several awards and grants (e.g., APART from the Austrian Academy of Sciences and Schrödinger from the Austrian Science Fund).

Simon Ganahl

Campus Medius

Digital Mapping in
Cultural and Media Studies

[transcript]

Based on international **peer reviews**, the research work leading to and the publication of this book were supported by the **Austrian Science Fund** (FWF: J 3181-G20 & PUD 17-G) and the **Austrian Academy of Sciences** (ÖAW: APART 11810).

FWF

Der Wissenschaftsfonds.

ÖAW
ÖSTERREICHISCHE
AKADEMIE DER
WISSENSCHAFTEN

Bibliographic information published by the Deutsche Nationalbibliothek: the Deutsche Nationalbibliothek lists this publication in the Deutsche Nationalbibliografie; detailed bibliographic data are available online at URL: dnb.d-nb.de



This work is licensed under **Creative Commons Attribution 4.0 (CC BY 4.0)**. This license permits unrestricted use and distribution of the respective material, provided that the creator(s), who retain(s) copyright, and the source are properly credited (see URL: creativecommons.org/licenses/by/4.0/deed.en).

Creative Commons license terms apply to original material only. The reuse of content cited from external sources (e.g., figures and excerpts) may require further permissions from the rights holder(s). The obligation to research and obtain such permissions lies with the reusing party.

First published in 2022 by transcript Verlag, Bielefeld © Simon Ganahl
Cover design: Stefan Amann (URL: proxi.me). Cover illustration: screenshot of the website campusmedius.net (text: Simon Ganahl, code: Andreas Krimbacher, design: Susanne Kiesenhofer) using a city map of Vienna from 1933 (© Freytag & Berndt) and building data of Schönbrunn Palace provided by the City of Vienna (URL: data.wien.gv.at). Translation: Katy Derbyshire (chap. II. Topography) and Maria Slater (Preface & chap. III. Topology). Proofreading: Maria Slater. Type-setting: Stefan Amann using IBM Plex. Printed by Majuskel Medienproduktion GmbH, Wetzlar. Printed on age-resistant, acid-free paper.

DOI: doi.org/10.14361/9783839456019

Print-ISBN: 978-3-8376-5601-5

PDF-ISBN: 978-3-8394-5601-9

ISSN of series: 2628-4995

eISSN of series: 2703-0415

Preface	7
I. Overview	17
1. Topography: <i>Campus Medius</i> 1.0	20
2. Topology: <i>Campus Medius</i> 2.0	28
3. Data Model and Infrastructure	36
4. Mapping Modern Media	44
II. Topography	53
1. Aspern Airfield	May 13, 1933, 2:00 p.m. 56
2. Lion of Aspern	3:00 p.m. 58
3. Lassalle Hof	3:30 p.m. 59
4. Adolf Hitler House	4:00 p.m. 61
5. UFA Ton Kino	4:45 p.m. 62
6. Burgtheater	7:30 p.m. 65
7. Engelmann Arena	8:30 p.m. 68
8. Friedensbrücken Kino	11:00 p.m. 71
9. <i>Neue Freie Presse</i>	6:00 a.m. 74
10. Schönbrunn Palace Gardens	9:00 a.m. 76
11. Tonkino Fischer	9:00 a.m. 83
12. Karl Marx Hof	10:00 a.m. 85
13. <i>Radio Wien</i>	10:20 a.m. 87
14. German Embassy	1:00 p.m. 90
15. Schwarzenbergplatz	May 14, 1933, 2:00 p.m. 92
III. Topology	95
1. How to Use Reason: Sovereign Signs	98
1.1 Leader: Ernst Rüdiger Starhemberg	100
1.2 Editorial: “Undesirable Visit”	116
1.3 Residence: Schönbrunn	130
1.4 Theater: Fascism as Tragedy	146
1.5 Reframing: “Anthem Chaos”	162

2. How to Capture Life: Examining Gazes	182
2.1 Parade: March on Vienna	184
2.2 Camera: Bell & Howell 2709	199
2.3 Montage: Perceptual Gymnastics	210
2.4 Cinema: Mabuse's Control Center	223
2.5 Exposure: "Lick Me in the Ass!"	236
3. How to Speak Up: Governed Transmissions	248
3.1 Radio: Mikes, Cables, Transmitters	250
3.2 Statistics: RAVAG Studies	264
3.3 Marketing: "Torches of Freedom"	278
3.4 Welfare: Educating New People	291
3.5 Cancellation: "Listener Strike"	306

IV. Appendix

1. List of Figures	318
2. List of Sources	329
2.1 Archival Documents	329
2.2 Books and Brochures	331
2.3 Journals and Newspapers	344
2.4 Films and Sound Recordings	351
2.5 Websites	351
3. Project Team	352
3.1 Project Head	352
3.2 Software Development	353
3.3 Design	353
3.4 Translations	354
3.5 Advisory Board	355

Preface

The research project *Campus Medius* has been presented and reviewed many times over recent years. This preface is structured around some of the questions that came up repeatedly during these verbal and written discussions and that are relevant for the book edition.

Why was the project given the title *Campus Medius*?

- The Latin expression *campus medius* can be translated into English as “middle field.” I chose it as the title of this research project in 2012 because conceptually it was a matter of **mapping mediality as an experiential field**. The title only gained its pedagogical significance in terms of a platform for media education during the series of courses called “**Mapping Modern Media**,” in which students describe and visualize everyday media experiences.

Why publish a book about a digital project?

- The project’s complete historical case study has been online since the launch of *Campus Medius 2.0* in April 2021. From the outset, I had planned to publish the results in book form once this point had been reached, because it is important to me to establish a sensible connection between new digital and traditional models of publication.¹ Here, sensible means that the different media forms are harnessed in their singularity. The website campusmedius.net offers users an interactive media experience comprising not only texts and images, but also films and sound recordings, as well as giving its **creators** the opportunity to correct and update the program code and content (at least for as long as there is funding for this process). In addition, this web application allows not only for the content of the historical case study to be imparted from multiple perspectives, but also for it to be mapped as if with a moving camera.

By contrast, the book concentrates its readers’ attention due to the nature of its inherent material isolation. Those who

1 See Anne Burdick, Johanna Drucker, Peter Lunenfeld, Todd Presner, Jeffrey Schnapp: *Digital_Humanities*, Cambridge: MIT Press 2012, p. 125.

read it are guided through the various sections of the *Campus Medius* research project. They can follow the cross references to footnotes, chapters, and figures, or they can opt to read the text from front to back—in the case of the printed version, without having to use a stationary or mobile computer. In order to exploit this quality of the medium, it was necessary to conceive of the book independently, i.e., without the need for readers to visit the website in parallel. As such, the book edition performs another function in the media network that is *Campus Medius*, namely archiving the project as of the status of version 2.0 from 2021. Nowadays, it is no longer an issue to save electronic data in the long term; the most important formats are established, and many academic libraries have set up digital repositories. What remains unresolved, however, is the question of how websites can be archived as a whole such that they remain usable for decades: after all, the interfaces between the back end and the server and the front end and the web browsers are subject to technological change.

- 1.3 *Campus Medius* runs on **stable infrastructure** and, in my view, has good chances of surviving. Nevertheless, this book—in both its print and electronic editions—is intended to document the project in a way that will remain legible even if the digital environment changes to such an extent that the website can no longer be used (or rather if there is no longer the funding to continue developing it). Conversely, the reference systems of campusmedius.net have inspired me to encourage non-linear readings of the book. For this reason, besides the footnotes, there are also references throughout to figures and chapters that invite readers to jump back and forth through the volume.² This is nothing new; indeed, it has been customary in scholarly literature for centuries. However, it was working on the website that prompted me to make more use of these typographical possibilities than is the norm in monographs.

- 2 In each chapter, the sources contained in the footnotes are listed in full upon first mention and in abbreviated form thereafter. The complete List of Sources (see chap. IV.2) can be found in the Appendix. The internal references to chapters and figures are linked in the electronic edition of the book, as are the external URLs and DOIs. The decision was made not to include an index due to the open-access PDF version of the publication, the full text of which can be searched just like the website campusmedius.net.

What do the theoretical concepts of the *dispositif* and the actor-network have to do with mapping?

“Untangling these lines within a social apparatus [*dispositif*] is, in each case, like drawing up a map, doing cartography, surveying unknown landscapes, and this is what he calls ‘working on the ground,’” Gilles Deleuze wrote of the philosophy of Michel Foucault.³ Put very simply, I understand the *dispositif* as a concept with which to analyze historical patterns of relations, and the actor-network in the sense of Bruno Latour as a perspective on actions in which the focus is on the connections between people and things. In turn, a map is in essence a visualization of a set of relations,⁴ that is, also a possibility to make *dispositifs* and actor-networks perceivable. Modern cartography has standardized a series of such visualization methods, all of which are not neutral but rather have their own histories.

III In the “**Topology**” of *Campus Medius 2.0*, the bird’s-eye perspective, the panorama, and the street view are interwoven in three media-historical networks, so-called *dispositifs* of mediation, which span from the seventeenth century to the present day. Using the example of the “**Turks Deliverance Celebration**” (II.10 (*Türkenbefreiungsfeier*)⁵ in Vienna on May 14, 1933, the aim is to show that these cartographic interfaces are worldviews in the ideological sense. In the case study, it was important to me not only to describe the *dispositifs* as historical patterns of relations by means of specific actors or mediators, but also

- 3 Gilles Deleuze: “What is a *dispositif*?,” in: Timothy J. Armstrong (ed.): *Michel Foucault Philosopher*, trans. Timothy J. Armstrong, New York: Routledge 1992 [French 1989], pp. 159–168, here p. 159.
- 4 See Todd Presner: “Lexicon,” in: Todd Presner, David Shepard, Yoh Kawano: *HyperCities. Thick Mapping in the Digital Humanities*, Cambridge: Harvard University Press 2014, pp. 12–21, here p. 15.
- 5 Upon mention in each chapter, the German original of key terms such as “Turks Deliverance Celebration” is given in italics in parentheses; thereafter, only the English translation is used. Titles of works cited in the running text—but not in footnotes—are given first in the original and subsequently translated into English in parentheses. Conversely, the original titles of smaller works mentioned in the running text, such as articles or speeches, are provided in italics in parentheses after their English translation in quotation marks for ease of reading. →

- III.1.5 to demonstrate opportunities for resistance. Consequently,
 III.2.5 the **reframing** of the “Emperor’s Song” (*Kaiserlied*) protests
 III.3.5 against sovereign signs, the **exposing** of the buttocks against
 examining gazes, and the **canceling** of radio licenses against
 governed transmissions.

**Why does the weekend of May 13 and 14, 1933, in Vienna
 serve as the historical starting point?**

- I.1 As I explain in the **Overview**, I became aware of May 13 and 14,
 1933, in Vienna while studying the *Third Walpurgis Night* by Karl
 Kraus. The political events of that weekend induced Kraus to
 come out in favor of the authoritarian politics of Austria’s feder-
 al chancellor Engelbert Dollfuss. What interested me most was
 the wide range of public gatherings in this time-space, which
 II was ultimately condensed into **24 hours in Vienna**: On the one
 hand the “Turks Deliverance Celebration” as a function that
 launched Austrofascism and the countermeasures taken by
 the National Socialist and the Social Democratic opposition;
 on the other hand the cultural events, such as those in the
 cinemas and theaters, which though at first glance seem to
 be unrelated are upon closer inspection interwoven with the
 political phenomena.

- IV.2 In addition to Kraus having drawn my attention to these
 happenings and my desire to understand their context, the
 rich media-historical **sources** spoke for choosing this case
 study. A wealth of textual, visual, and acoustic documents
 provided the opportunity to observe and convey the historical
 events from various standpoints. Furthermore, I consider the
 weekend of May 13 and 14, 1933, in Vienna and specifically the
 “Turks Deliverance Celebration” to be relevant in genealogical
 terms, in other words in the sense of a history of the present.
 By portraying the events from multiple perspectives, the
 intention is for manifest networks of modern media history

- As proper nouns, the names of political parties—and associated
 adjectives—have been capitalized, e.g., Christian Social Party, Christian
 Social federal chancellor; where used in the more general sense of a
 political theory or movement rather than a specific political party, such
 terms are written in lower case, e.g., socialist principles. In order to avoid
 misunderstandings, we also decided to replace the German letter “ß” with
 “ss” in the English edition of the book, e.g., Dollfuss instead of Dollfuß.

to emerge that not only make clear the media infrastructure that facilitated (Austro-)Fascism but also raise awareness of the ways in which these historical nexuses shape current media experiences.

Where is *Campus Medius* located in the research field of the digital humanities?

The *Digital Humanities Manifesto* was a key incentive for *Campus Medius*.⁶ Inspired by avant-garde manifestos, the text written by Jeffrey Schnapp and Todd Presner among others in 2008/9 called for a qualitative shift in the digital humanities, for interdisciplinary collaboration, careful curating, and multi-media publications. In the question below about authorship, I describe the genesis of the website campusmedius.net, in which the specific personal and institutional influences are made clear. There it becomes evident that *Campus Medius* is a digital project that builds on corresponding research undertaken in the School of Media Studies at The New School in New York and in the Center for Digital Humanities at UCLA.

Generally, but also with regard to the institutionalization of the research field in the German-speaking world, *Campus Medius* is located on the periphery of the digital humanities. Entirely contrary to the trend, it does not follow a big data approach but works with *small data*, which are dis- and reassembled from the perspectives of cultural and media studies, as well as informatics and design. It is not a quantitative but a qualitative DH project, which was carried out as a long-standing multidisciplinary collaboration and attempts to connect traditional with digital publication models. In this sense, *Campus Medius* pursues a sideline of the digital humanities and hopefully has a bearing on the “mainline.”

Who authored *Campus Medius*?

The historical case study of *Campus Medius* is a monograph in the field of cultural and media studies, which was published as a website in several phases from 2014 to 2021 and has now been released in the form of a book. I am the author of

6 See Jeffrey Schnapp et al.: *The Digital Humanities Manifesto 2.0*, 2009, URL: www.humanitiesblast.com/manifesto/Manifesto_V2.pdf.

IV.3 this work to the extent that I conceived and direct the project, researched and evaluated the sources, and wrote all the texts. However, it would not have been possible for me to realize the project without working together with others. Besides scholarly discussions and financial support, it required a decade of close **cooperation** with computer scientists, designers, and translators, the most important stages of which are described chronologically below.

The theoretical and empirical concept of *Campus Medius* was mainly developed in Vienna and Zurich. In Vienna it was primarily the research group Mediologie@Wien, founded by Arndt Niebisch and Martina Süess under the professorship of Eva Horn, as well as my PhD supervisors Roland Innerhofer and Wolfgang Duchkowitsch, whose expertise in the fields of literary and media studies shaped the project. The historical case study was also influenced by the work on the “Memory of the Turks” (*Türkengedächtnis*) conducted by Johannes Feichtinger and Johann Heiss at the Austrian Academy of Sciences.

For Zurich, the first person who should be named is the historian Philipp Sarasin, in whose department I was involved in founding the *foucaultblog* as a visiting researcher. From this digital platform, I developed the open-access journal *Le faucaldien* together with Maurice Erb and Patrick Kilian, which has been published by the London-based Open Library of Humanities since 2017.⁷ It was predominantly this editorial work that deepened my understanding of the concepts of the *dispositif* and the actor-network.

I.1 **Campus Medius 1.0** emerged from 2012 at the New School in New York and was based on the model of the Urban Research Tool developed by Shannon Mattern and Rory Solomon. Shannon’s urban media archaeology left a definite mark on the project, and Rory was instrumental—not only as the technical lead but also conceptually—in the first version of the website *campusmedius.net* from 2014, on which Darius Daftary as programmer, Mallory Brennan as designer, and Katy Derbyshire as translator also collaborated. This work was funded by an Erwin Schrödinger fellowship (J 3181-G20) from the Austrian Science Fund (FWF).

7 From 2022 the journal appears under the title *Genealogy+Critique*.

The further development of the project was made possible by an APART fellowship (11810) from the Austrian Academy of Sciences, which led me to the Center for Digital Humanities at UCLA in 2016. There I had the opportunity to discuss the plans for *Campus Medius* and hold the course “**Mapping Modern Media**” for the first time. Besides David D. Kim and Miriam Posner, Todd Presner must be mentioned at this point: he supported the project both on an organizational level and with his expert knowledge. The *HyperCities* mapping platform he directed was a model for *Campus Medius*, which—entirely in the spirit of the allegory—is a dwarf standing on the shoulders of this giant.

Continuing chronologically, next I would like to draw attention to the Critical Genealogies Workshop in which I was invited to participate in Denver in 2016. Carefully curated by Verena Erlenbusch-Anderson and Colin Koopman, this meeting to debate ongoing genealogical works served as a further bridge to help me navigate from the theoretical concepts to the empirical and digital realization of *Campus Medius 2.0*. My conversations with Robert W. Gehl and Thomas Nail influenced the subsequent direction taken by the project to a greater degree than they are probably aware.

Back in Vienna, it was again Roland Innerhofer who created the conditions at the Department of German Studies that allowed me to complete my research. Beneficial in this regard were on the one hand my collaboration on the lecture series “Germanistik digital” organized by Ingo Börner, Wolfgang Straub, and Christian Zolles, and on the other a series of workshops initiated by Katharina Prager, which in cooperation with the Vienna City Library and the Austrian Centre for Digital Humanities aimed to connect various digital projects on Viennese Modernism. Concerning the technical infrastructure, my thanks go to Susanne Blumesberger and Raman Ganguly for providing *Campus Medius* with full access to the digital repository PHAIDRA, and to the head of the Department of German Studies for supplying us with a virtual server at the Vienna University Computer Center.

Moreover, I owe a deep debt of gratitude to Andreas Krimbacher and Susanne Kiesenhofer, who developed ***Campus Medius 2.0*** with me for several years. As a geomatics engineer, Andreas engaged with my cultural and media studies

thinking with curiosity and flexibility and conversely did not tire of explaining to me how databases and interfaces work. He authored the source code of the second version of the website campusmedius.net from 2021, which he programmed exclusively with open-source software and made freely available on GitHub.⁸ With her expertise in design and information technology, Susanne was constantly involved in the project's implementation and dealt with every visual detail with artisanal precision, including the graphic icons for which Mallory Brennan had conducted important preliminary work based on Otto Neurath's ISOTYPE. In this context, I would also like to thank Maria Slater for her perseverance and precision when translating from the German into English. A dozen rounds of editing were needed for the various lyrics for Haydn's

III.1.5 **“Emperor’s Song”** alone in order to keep the translation of the content and poetry as faithful as possible to the original.

That the book edition of *Campus Medius* has now been released in German and English both in print and electronically as an open-access monograph was made possible by a publication grant (PUD 17-G) from the Austrian Science Fund (FWF). The design of the cover and the layout, as well as the typesetting, was undertaken by Stefan Amann, to whom I offer my heartfelt thanks for his patience during the creative process and for his typographic accuracy. The collaboration with the transcript publishing house, namely with Daniel Bonanati and Gero Wierichs, was exceptionally transparent and professional. Compared to other publishing offers, transcript stood out not only for its specialism and independence, but also for its comprehensive physical and digital distribution channels, openness when it came to matters of copyright,⁹ and clear cost-benefit ratio. That may seem very pragmatic, but

- 8 See URL: github.com/campusmedius/campusmedius.
- 9 Apart from the works cited in *Campus Medius*, which are protected by copyright, this book's content is—in line with the website campusmedius.net—available open access under Creative Commons CC BY 4.0. This license permits unrestricted use and distribution of the respective material, provided that the creator(s), who retain(s) copyright, and the source are properly credited. Preliminary versions of the first chapter (Overview) were published in Ingo Börner, Wolfgang Straub, Christian Zolles (eds.): *Germanistik digital. Digital Humanities in der Sprach- und Literaturwissenschaft*, →

for a scholarly publication financed with public funds on the basis of international peer reviews, in my opinion those are the most important criteria for choosing a publishing house.

Regarding the future of *Campus Medius*, its inclusion in university teaching is key—something that has become established in recent years and that I would like to continue to develop. After devising “Mapping Modern Media” at the Center for Digital Humanities at UCLA, I was invited to regularly hold the course at the University of Liechtenstein and at the University of Applied Sciences in Vorarlberg, Austria, for which I would like to thank in particular Roman Banzer, Markus Hanzer, Margarita Köhl, Monika Litscher, as well as Hubert Matt who generally offered considerable advice on the project. I also want to express my thanks to the dozens of students who attended these courses and whose works continue to support and motivate me to develop *Campus Medius* into a digital platform where everyday media experiences can be described and visualized. The discussions in the context of the research network YouthMediaLife, which Susanne Reichl and Ute Smit founded at the University of Vienna, have further contributed to the realization of these plans. *Campus Medius* also serves media education to the extent that the project’s historical case study provides the foundation for the introductory lecture series on the history of media and communication, which I have held at the Department of Communication at the University of Vienna since 2020. My sincere thanks go to Petra Herczeg, Klaus Lojka, Valerie Lechner, and Krisztina Rozgonyi for this opportunity.

I am aware that I am now testing my readers’ patience, but I would like to mention a few more people who did not make an appearance in this chronology yet helped me to conceptualize or implement *Campus Medius*. With thanks, I

- Vienna: facultas 2018, pp. 104–117; *spheres. Journal for Digital Cultures*, #1: Politics after Networks (2018), DOI: doi.org/10.25969/mediarep/3814; *medien & zeit*, 36/1 (2021), pp. 42–52. In an educational setting, the third chapter (Topology) constitutes the reader for the lecture series STEOP A: VO HIST in the Department of Communication at the University of Vienna, which has been published by facultas under the title *Medien- und Kommunikationsgeschichte* (“History of Media and Communication”) since 2020.

will therefore name them in alphabetical order by surname (and I ask for the forgiveness of those whom I have omitted to list here): Clemens Apprich, Thomas Ballhausen, Paolo Carpignano, Sabrina Corbellini, Georg Eckmayr, Alexandra Egger, Christian Fleck, Daniela Franke, Andreas Gelhard, Tanja Gnosa, Gerhard Gonter, Wolf Harranth, Kristina Höch, Margriet Hoogvliet, Rastislav Hudak, Thomas Hübel, Sigrid Kammerer, Franziska Klemstein, Andreas Koop, Anna Lindner, Hannes Mittergeber, Wolfgang Pensold, Robert Pfundner, Martin Reinhart, Barry Salmon, Gottfried Schnödl, Mathias Schönher, Elena Vogman.

Instead of thanking my wife and daughter at the end of this preface, I had better apologize to them for being unfaithful, for the countless hours that I spent caring for this illegitimate child, which though not yet fully grown is now at least mature enough to be let out into the world in the hope that it will make friends.

Vienna, fall 2021

Overview:
The development
of the project
Campus Medius
from a historical
case study to a
mapping platform.

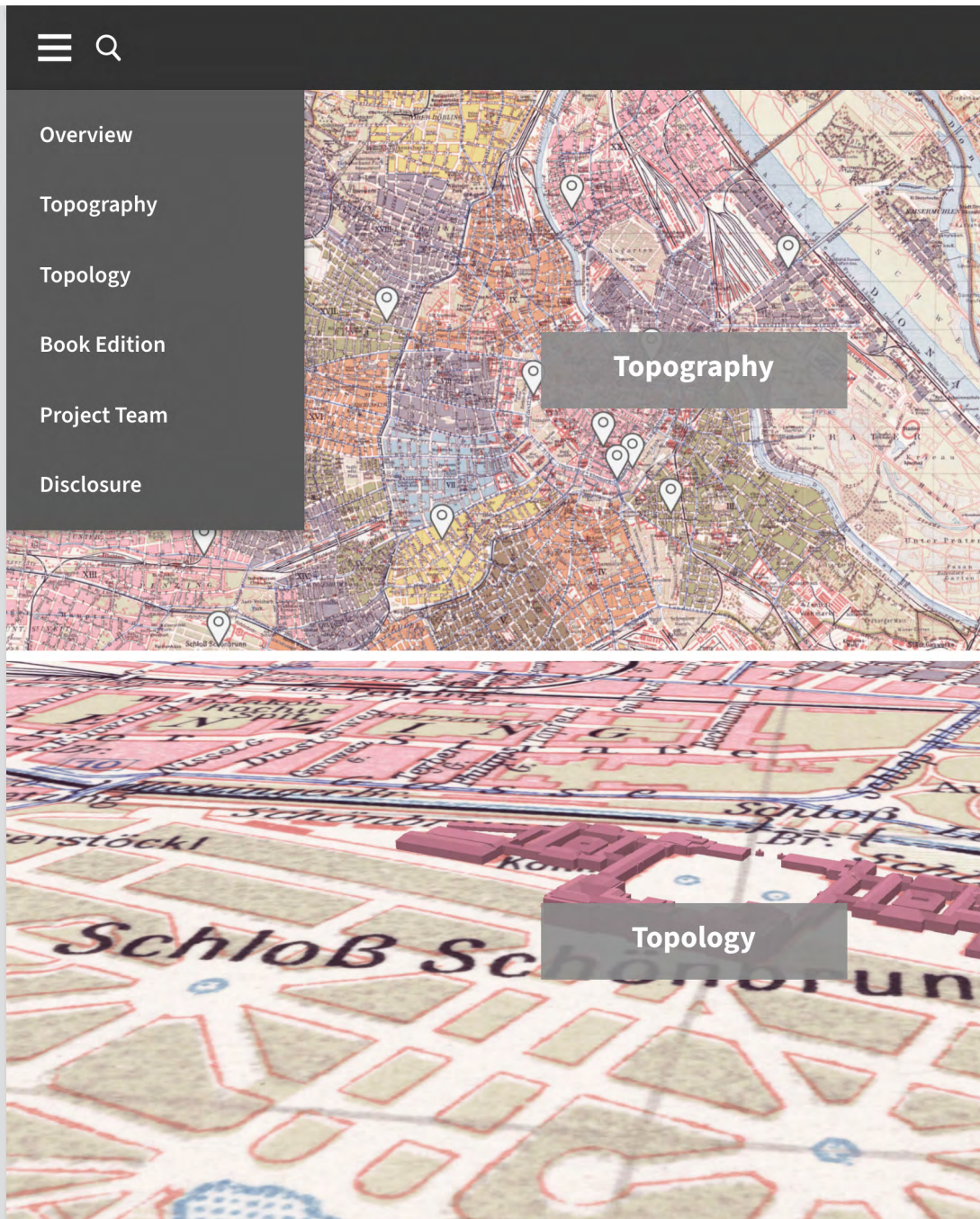

Fig. 1: Screenshot of the website campusmedius.net (desktop version 2.0/2021) showing the start page with the opened menu and the selection of the page “Overview” (text: Simon Ganahl, code: Andreas Krimbacher, design: Susanne Kiesenhofer).



Campus Medius explores and expands the possibilities of digital mapping in cultural and media studies. The fields on the left lead directly to the historical case study. However, we recommend reading the introductory overview first.

[OVERVIEW](#)[BOOK EDITION](#)[PROJECT TEAM](#)

The QR code leads
to the corresponding
web page.



1. Topography: *Campus Medius* 1.0

The idea for this mapping project originated in my doctoral studies on the media references in the writings of Karl Kraus (1874–1936) and Peter Altenberg (1859–1919), where I investigated a text that Kraus had written in Vienna in 1933: the *Dritte Walpurgisnacht* (*Third Walpurgis Night*).¹⁰ In this 300-page essay, the events of a weekend that May are central to its judgment about the contemporary political situation, namely the Nazi “seizure of power” in Germany and the Austrian response to these developments. By researching what had happened in Vienna on May 13 and 14, 1933, I soon understood why Kraus had experienced this weekend as a turning point. Consequently, I decided to represent fifteen selected events within twenty-four hours, from Saturday at 2 p.m. to Sunday at 2 p.m., on a digitized map of Vienna from 1933. Supervised by the media scholar Shannon Mattern, the initial version of the website was developed in collaboration with the software engineers Rory Solomon and Darius Daftary and the designer Mallory Brennan at The New School in New York and launched at campusmedius.net in July 2014.¹¹

The selection of the empirical material was also influenced by the concept of the *chronotope*. In the 1930s, Mikhail Bakhtin had written an essay on time-spaces or space-times in literature from antiquity to the Renaissance, which became very important in literary studies after its publication in 1975.¹² This approach inspired me to limit the historical case study to

- 10 See Simon Ganahl: *Karl Kraus und Peter Altenberg. Eine Typologie moderner Haltungen*, Konstanz: Konstanz University Press 2015, pp. 21–111, DOI: doi.org/10.26530/oapen_574830. A digital edition of the *Third Walpurgis Night* is online available at URL: kraus1933.ace.oeaw.ac.at.
- 11 Shannon Mattern has since published her urban media archaeology, which had a formative influence on *Campus Medius*, in two books: *Deep Mapping the Media City*, Minneapolis: University of Minnesota Press 2015; *Code + Clay... Data + Dirt. Five Thousand Years of Urban Media*, Minneapolis: University of Minnesota Press 2017.
- 12 See Mikhail M. Bakhtin: “Forms of Time and of the Chronotope in the Novel” [Russian 1975], in: *The Dialogic Imagination. Four Essays*, ed. Michael Holquist, trans. Caryl Emerson and Michael Holquist, Austin: University of Texas Press 1981, pp. 84–258.

exactly twenty-four hours in Vienna—a temporal and spatial unity that not only emerged in the course of events, but also resembles the most significant chronotope of the Modernist novel. Just think of James Joyce’s *Ulysses*, Virginia Woolf’s *Mrs Dalloway*, Andrei Bely’s *Petersburg*, or—to name another medium—the documentary *Berlin: Symphony of a Metropolis* by Walter Ruttmann. In all these artworks from the first third of the twentieth century, one finds the attempt to capture modernity in a very specific time-space: a day in the city.¹³

The historical chronotope of twenty-four hours in Vienna on May 13 and 14, 1933, is marked by so-called “Turks Deliverance Celebrations” (*Türkenbefreiungsfeiern*) held by the Austrian Homeland Protection (*Heimatschutz*) in the **gardens of Schönbrunn Palace** and by the NSDAP in the **Engelmann Arena**. As the 250th anniversary of the city’s liberation from the Ottoman siege in mid-September 1683, celebrated in advance for reasons of propaganda, these competing rallies were oriented from the outset on media communication: prepared by the party-political press, partially broadcast live on **Radio Wien**, and captured in newsreels. To create counter-publicity, the Social Democrats published programmatic editorials and organized “**freedom celebrations**” in the municipal housing projects (*Gemeindebauten*). While the Burgtheater staged the play *Hundred Days*, cowritten by Benito Mussolini, several cinemas were screening Fritz Lang’s sound feature *The Testament of Dr. Mabuse*, a film banned in Germany. In other movie theaters, adherents of National Socialism viewed the documentary *Germany Awakes*, and a group of communists showed Sergei Eisenstein’s *Battleship Potemkin and Turksib* by Viktor Turin. Moreover, the Sunday edition of the *Neue Freie Presse*, Vienna’s most important bourgeois newspaper, printed an essay entitled “**Humbug, Bluff, and Ballyhoo**” on public relations as practiced by Edward Bernays, a nephew of Sigmund Freud.

On the website, users can discover what was happening simultaneously at different places in Vienna by moving the

13 See Simon Ganahl: “Der monströse Fouleuze. Eine philosophische Lektüre von Andrej Belyjs *Petersburg*,” in: *Le foucaldien*, 3/1 (2017), DOI: doi.org/10.16995/lefou.23.

twenty-four-hour timeline. The interactive map also makes it possible to give a spatial overview of the events. Inspired by the research platform *HyperCities*,¹⁴ to which *Campus Medius* in general owes a great deal, we not only geo-referenced their sites but used an established technique for historical mapping projects known as *rectification*. In our case, a city map of Vienna from 1933 was scanned with high resolution at the Austrian National Library,¹⁵ converted into a GeoTIFF file, and rectified to align with the underlying GIS data of OpenStreetMap.¹⁶ This technological procedure discomfited me because of the idea that a digital map represents the reality from which a printed map more or less deviates. What actually happens in the process of rectification, though, is a translation between different projections of reality that ought to be traced back to the historical conditions of their emergence.¹⁷ Due to this critique of the cartographical approach, we have striven to question and alienate these standardized representations of time and space in the current version of the project that I will discuss in the **second part** of the introduction.

I.2

Fig. 2, p. 24

By selecting a pin on the map, an **actor-network** of the respective event popped up in the initial release of *campusmedius.net*. This visualization was derived from actor-network theory, which basically states that it is not a subjective consciousness that decides to act, and then things happen accordingly—in other words, that actions should not be understood as human intentions, but rather as interplays between human and nonhuman actors.¹⁸ We styled the actor icons along the lines of the International System of Typographic Picture Education (ISOTYPE), a conceptually universal picture language developed under the direction of the political economist and Austro-Marxist Otto Neurath, a member of the Vienna

14 See URL: www.hypercities.com.

15 See *Gesamtplan von Wien*, Vienna: Freytag & Berndt 1933, source: Austrian National Library, K III 101617.

16 See URL: www.openstreetmap.org.

17 See Todd Presner: “The View from Above/Below,” in: Todd Presner, David Shepard, Yoh Kawano: *HyperCities. Thick Mapping in the Digital Humanities*, Cambridge: Harvard University Press 2014, pp. 84–127, here pp. 110–118.

18 See Bruno Latour: *Reassembling the Social. An Introduction to Actor-Network-Theory*, New York/Oxford: Oxford University Press 2005.

Fig. 3, p. 26

Circle, from the mid-1920s onward.¹⁹ In our project, however, ISOTYPE is not regarded as a universal design concept, but rather as a visual vocabulary that is closely related to the historical setting of the case study. In *Campus Medius* 1.0, the colors of the icons designated political backgrounds, with red for socialist and communist, green for Austrofascist, brown for National Socialist, and blue for bourgeois actors. If the user clicked on this actor-network window, a **multimedia description** of the associated event opened up, featuring photographs, sound recordings, movie clips, archival documents, press articles, etc.

This is, by and large, the first version of *campusmedius.net* as the website went online in 2014—a kind of digital exhibition. The project’s take on the research field of digital humanities has been strongly influenced by the *Digital Humanities Manifesto 2.0*, which argues for “the scholar as curator and the curator as scholar.”²⁰ With every historical document that is digitized, this claim becomes more important. By October 29, 2020, the Austrian National Library, for example, had made twenty-three million newspaper pages available in Austrian Newspapers Online (ANNO):²¹ What is such “big data” good for if it is not correlated in meaningful ways? One way is to develop algorithms that help recognize patterns; another way is to curate this cultural heritage in digital monographs. We started with the latter approach, used the preliminary results to translate our theoretical concepts into a data model, and have begun to devise an algorithmic analysis based on the second version of the project that I will present in the here following section.

- 19 See Otto Neurath: *International Picture Language. The First Rules of Isotype*, London: Kegan Paul 1936, and Christopher Burke, Eric Kindel, Sue Walker (eds.): *Isotype. Design and Contexts. 1925–1971*, London: Hyphen Press 2013.
- 20 Jeffrey Schnapp et al.: *The Digital Humanities Manifesto 2.0*, 2009, p. 8, URL: www.humanitiesblast.com/manifesto/Manifesto_V2.pdf.
- 21 See URL: anno.onb.ac.at.

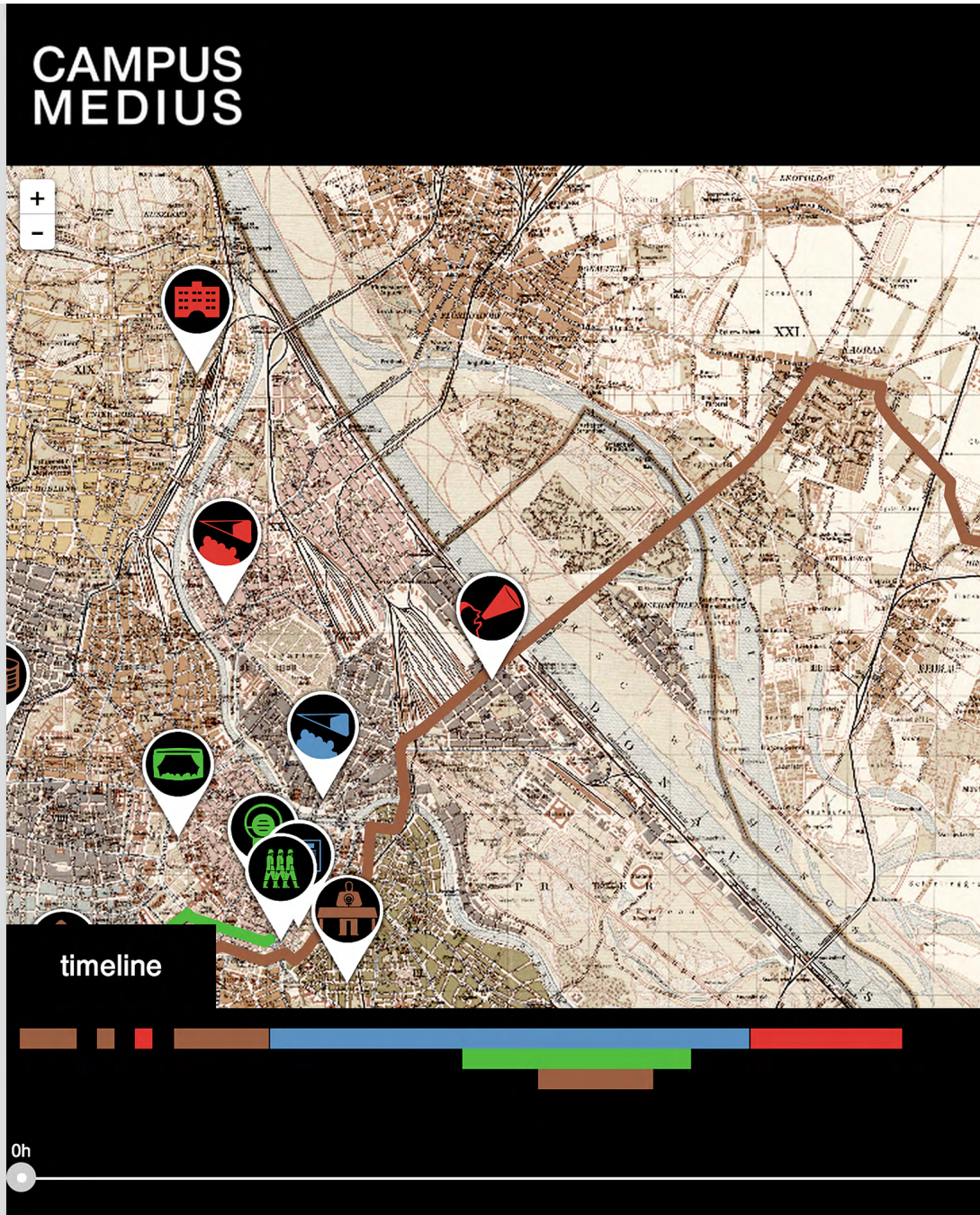

Fig. 2: Screenshot of the website campusmedius.net (desktop version 1.0/2014) showing the map of Vienna from 1933 rectified to align with the underlying OpenStreetMap, the twenty-four-hour timeline from May 13, 1933, at 2 p.m.,

about

team

OpenStreetMap contributors (present day)

Freytag & Berndt: Gesamtplan von Wien (1933)

Aspern Airfield
 May 13, 1933
 2:00 pm – 2:45 pm

read more »

24h

Leaflet

to May 14, 1933, at 2 p.m., and the opened actor-network window of the event “Aspern Airfield” (text: Simon Ganahl, back-end coding: Rory Solomon, front-end coding: Darius Daftary, design: Mallory Brennan).

**CAMPUS
ME**

Radio Wien

May 14, 1933
10:20 am – 11:05 am

📅 From 10:20 to 11:05 a.m. on May 14, 1933, Radio Wien broadcasts the speeches held at the "Turks Deliverance Celebration" in [Schlosspark Schönbrunn](#). The speakers at the event, commemorating Vienna's liberation from the Second Turkish Siege in 1683, are the chief of the Home Guard Ernst Rüdiger Starhemberg, security minister Emil Fey, and federal chancellor Engelbert Dollfuß, who says into the row of carbon and condenser microphones: "Foreign spirit and foreign ideas are in our people, have lodged themselves and brought evil upon us." [1] To combat this enemy ideology—namely socialism—the Austrian government, which has taken an authoritarian line since March of 1933, uses radio for its propaganda purposes. [2]

The live broadcast of the rally in Schönbrunn breached a taboo and prompted public protest. The Social Democratic *Arbeiter-Zeitung* reported on May 16, 1933, that more than 10,000 listeners had cancelled their radio registration because "on Sunday—deviating from the previous practice of not transmitting party-political events on the radio—the Austrian Home Guard's so-called 'Turks Deliverance Celebration' was broadcast." [3] Since its foundation in 1924, the broadcasting company Radio-Verkehrs-AG (RAVAG) had been obliged to maintain political neutrality, which was monitored by an advisory board at weekly meetings. The Federal Press Service within the chancellery did exert an influence over news programs; however, there were no party-political speeches on Austrian radio. The opposition now criticized that the government was abusing the new medium as its mouthpiece.

Photographs of Schönbrunn, a

timeline

Fig. 3: Screenshot of the website [campusmedius.net](#) (desktop version 1.0/2014) showing the opened information of the event "Radio Wien" (text: Simon Ganahl, back-end coding: Rory Solomon, front-end coding: Darius Daftary, design: Mallory Brennan).

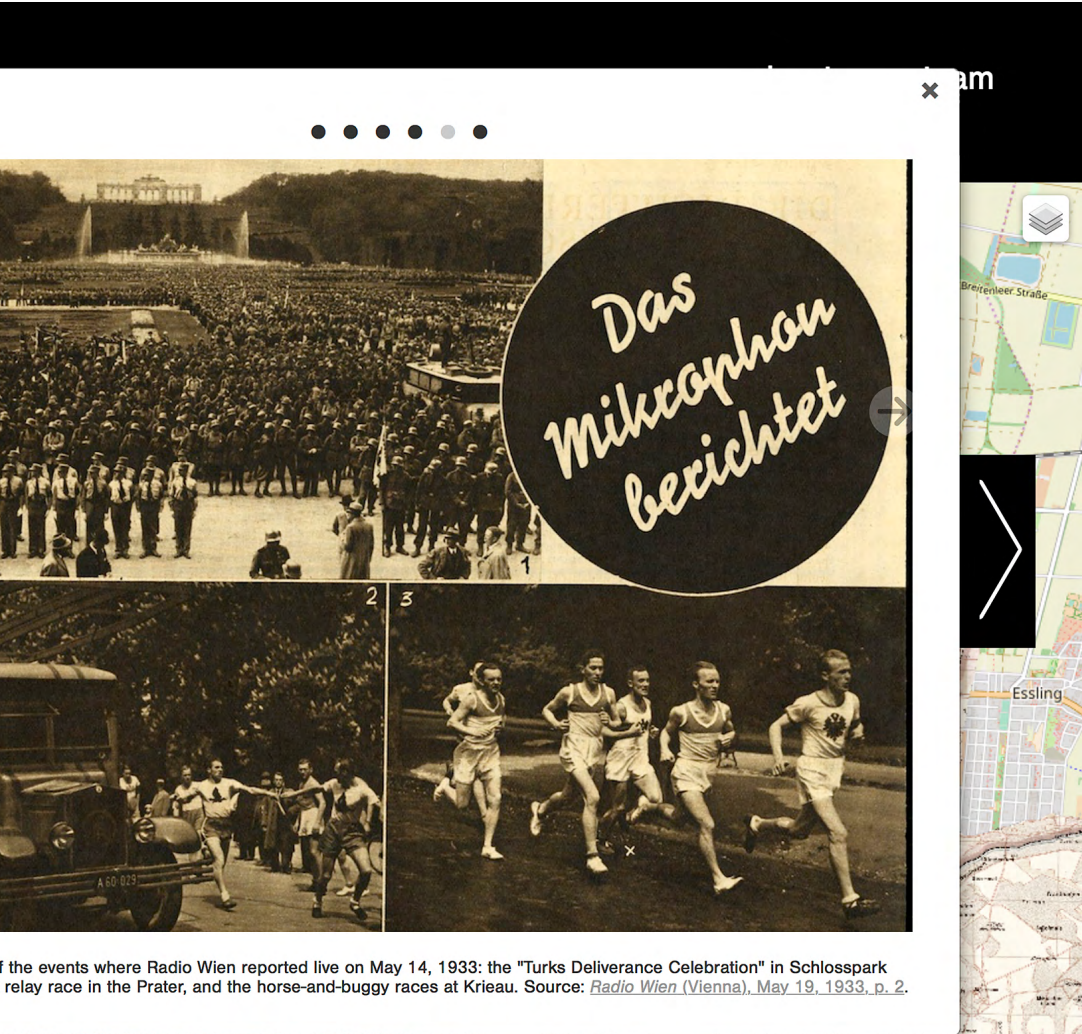

of the events where Radio Wien reported live on May 14, 1933: the "Turks Deliverance Celebration" in Schlosspark relay race in the Prater, and the horse-and-buggy races at Krieau. Source: *Radio Wien (Vienna), May 19, 1933, p. 2.*



2. Topology: *Campus Medius 2.0*

II &
Fig. 18, p. 54

III &
Fig. 35, p. 96

II.10 &
Fig. 29, p. 80

Table 1, p. 31

In the current version of *campusmedius.net* published in April 2021, which was programmed by Andreas Krimbacher and designed by Susanne Kiesenhofer, the aforementioned overview of the historical chronotope continues to exist in the “**Topography**” module, comprising as before the twenty-four-hour timeline and the rectified map of Vienna from 1933. The fifteen events, however, are only marked by ordinary pins as the concept of the actor-network moved to a new module that we call “**Topology**.” In this section, we focus on the main event of the selected time-space: the “**Turks Deliverance Celebration**” held by the Austrian Homeland Protection in the gardens of Schönbrunn Palace on May 14, 1933, which is imparted from a bird’s-eye perspective, panoramically, and in street view by five mediators each. The narrative technique of telling a story from different perspectives is very common in novels, films, and TV serials. In *Campus Medius 2.0*, this approach is deployed to construct ideal-typical interfaces meant to spotlight and denaturalize representations of time and space that have become standardized in digital cartography.

I drew a **table** that outlines this multi-perspectival account of the “Turks Deliverance Celebration.” Conceptually, the scheme is based on a question that has motivated the project from the outset: What is a media experience? Or more precisely, what does it mean to have a media experience in modernity? This line of inquiry derives from Michel Foucault’s studies on modern possibilities of experiencing.²² But can we also conceptualize *mediality* as an experiential field in the Foucauldian sense? What possibilities of having media experiences have opened up in the modern age since about the mid-seventeenth century? The table answers this question with a bold thesis: having a media experience in modern societies essentially

- 22 As Foucault wrote in retrospect, his studies of modern madness, disease, criminality, and sexuality explored “the historical *a priori* of a possible experience.” (Michel Foucault: “Foucault,” trans. Robert Hurley [French 1984], in: *Essential Works of Foucault. 1954–1984*, vol. 2, ed. James Faubion, Harmondsworth: Penguin 2000, pp. 459–463, here p. 460 [emphasis in original].)

Fig. 4, p. 32

means using reason in sovereign signs, capturing life in examining gazes, or speaking up in governed transmissions. These three possibilities of having media experiences—in Foucauldian terms: *dispositifs* of mediation—materialize in heterogeneous *mediators*. For our case study on the “Turks Deliverance Celebration,” each mediation is expressed by five selected mediators whose **icons** are designed along the lines of ISOTYPE and that are associated in specific types of connection, in distinct *topologies*. Are the mediators marking out territories or spreading in an unlimited space? Do they end sometime or potentially exist infinitely? Is a centralized or an equalized distribution taking place? Etc. The mapping *interfaces* result from these *dispositifs* of mediation, because seeing things from a bird’s-eye perspective, panoramically, or in street view entails certain notions of the world, certain ideologies that we aim to elucidate.²³

III.1 &
Fig. 36, p. 99
III.1.1 &
Fig. 37, p. 104

Fig. 5, p. 34

So how was the new Topology module implemented on the website? I start with the mediation “**How to Use Reason: Sovereign Signs**,” taking the example of the mediator **Ernst Rüdiger Starhemberg**, the federal leader of the Austrian Homeland Protection and initiator of the “Turks Deliverance Celebration” in Vienna on May 14, 1933. Instead of a timeline, the Topology includes a selector beneath the map where the users can switch between the three mediations. In this case, the mediators are viewed from above and navigated via zooming. The network is centralized, that is, all navigations have to pass a **central node**: the transcendent bird’s-eye view, overarching the earth’s surface, which is not only the perspective of god, but also of the sovereign monarch overseeing his or her territory. This worldview was very familiar to Starhemberg, who came from an old aristocratic family of the Habsburg Monarchy, which ended together with World War I in 1918. One of his ancestors was Count Ernst Rüdiger von Starhemberg, the successful military commander of Vienna during the Ottoman siege of the city in summer 1683.

23 On interfaces as practices of mediation, see Alexander R. Galloway: *The Interface Effect*, Cambridge: Polity 2012, and Johanna Drucker: *Graphesis. Visual Forms of Knowledge Production*, Cambridge: Harvard University Press 2014.

Mediation	Media	
demand & response	medium	mediator
How to Use Reason: Sovereign Signs	leader editorial residence theater reframing	Ernst Rüdiger Starhemberg “Undesirable Visit” Schönbrunn Fascism as Tragedy “Anthem Chaos”
How to Capture Life: Examining Gazes	parade camera montage cinema exposure	March on Vienna Bell & Howell 2709 Perceptual Gymnastics Mabuse’s Control Center “Lick Me in the Ass!”
How to Speak Up: Governed Transmissions	radio statistics marketing welfare cancellation	Mikes, Cables, Transmitters RAVAG Studies “Torches of Freedom” Educating New People “Listener Strike”

Led by Federal Chancellor Engelbert Dollfuss, the Austrian government adopted an authoritarian course in March 1933. His cabinet prevented parliament from working and governed by emergency decree, but it was not clear that spring how matters would develop. Supported by **Benito Mussolini**, Italy’s Fascist prime minister, Starhemberg suggested holding a mass rally of the Austrian Home Guards (*Heimwehren*) to celebrate the 250th anniversary of Vienna’s liberation from the second Ottoman siege, which actually took place in mid-September 1683.²⁴ However, the plan, supported by the **party-political press**, was to give a public signal of Austria as a Fascist sovereign nation earlier in the year, and it worked out: to the strains of the ambiguous **national anthem**, the chancellor swore fidelity to the leader of the Homeland Protection in front of allegedly forty thousand Home Guard members, deployed radially in the **Baroque gardens** starting

III.1.4

III.1.2 & Fig. 44, p. 123

III.1.5

III.1.3

24 See Ernst Rudiger Starhemberg: *Between Hitler and Mussolini*, New York/London: Harper & Brothers 1942, pp. 95–117.

Topology			Interface	
space	time	value	perspective	navigation
limited	infinite	centralized	bird's-eye	zooming
limited	finite	ranked	panorama	panning
unlimited	finite	distributed	street view	tracking

Table 1: The three *dispositifs* of mediation implemented in the Topology module of the website *campusmedius.net* (version 2.0/2021) as a multi-perspectival account of the “Turks Deliverance Celebration” held in Vienna on May 14, 1933.

from the balcony of Schönbrunn Palace, where Dollfuss and Starhemberg were standing.²⁵

III.2 &
Fig. 73, p. 183

III.2.2 &
Fig. 85, p. 206

III.2.1

In the second mediation, “**How to Capture Life: Examining Gazes,**” the users view and navigate the map panoramically. Its network is ranked, meaning they need to pan from the first to the fifth mediator one after another. The 35 mm movie camera “**Bell & Howell 2709,**” which was launched in 1912 and soon came to be the American standard model, may serve as an exemplary mediator for this interface. I recognized the distinctive camera on the very right of a photograph that shows the **Home Guard parade** following the rally in Schönbrunn, captured on Mariahilfer Strasse near Vienna’s western

25 See “Der Zug der Vierzigtausend durch Wien,” in: *Reichspost* (Vienna), May 15, 1933, pp. 1–3.



Fig. 4: Mediator icons, designed by Susanne Kiesenhofer and Mallory Brennan along the lines of Otto Neurath's International System of Typographic Picture Education (ISOTYPE), implemented in the Topology module of the website *campusmedius.net* (version 2.0/2021).

Fig. 81, p. 200

railway station.²⁶ On a high-resolution scan of **this picture**, it was possible to identify the model and to realize that this unique camera had been equipped with an aftermarket motor and apparatus for recording optical sound. The reel was shot for the German version of *Fox Movietone News* and has been preserved in the Filmarchiv Austria.²⁷

III.2.3

I have been particularly interested in the question of which kind of film this assemblage was able to shoot, how this specific camera and the following **editing process** made it possible to capture the movement of the parade. In principle, this upgraded Bell & Howell 2709 reviewed the paramilitary procession not unlike the members of the Austrian government awaiting

26 See "Türkenbefreiungsfeier" (photograph, Vienna, May 14, 1933), source: Austrian National Library, 66.287 B.

27 See "Die Türkenbefreiungsfeier des österreichischen Heimatschutzes in Wien," in: *Jahresschau 1933 der Bundespolizeidirektion in Wien. Eine Chronik im Laufbild*, 35 mm film, source: Filmarchiv Austria, JS 1933/8.

III.2.4 the march-past at Schwarzenbergplatz in the city center. And the spectators viewing the newsreel in the **movie theaters** later on, were they not taking up a similar position of examining these moving bodies? A form of disciplinary examination that a few residents of Vienna's Lassalle Hof literally inverted the day before when they turned their **exposed buttocks** instead of their eyes toward a passing convoy with Nazi politicians from Germany.²⁸

III.2.5 &
Fig. 102, p. 238

III.3 &
Fig. 106, p. 249

III.3.1 &
Fig. 108, p. 254

The third mediation, "**How to Speak Up: Governed Transmissions,**" is determined by the mapping interface of the street view. In its distributed network, the users can navigate by tracking in all directions but are not able to escape this narrow perspective. As a corresponding mediator, I lastly present the **technical apparatus** that broadcast the speeches held at the "Turks Deliverance Celebration" live on *Radio Wien*.²⁹ These voices, transformed into electricity by a dynamic or carbon microphone, arrived at the tube amplifier by cable, were relayed from Schönbrunn Palace to the headquarters of the Austrian Radio Verkehrs AG (RAVAG) in the inner city possibly by a shortwave transmitter, but probably via phone lines, and transferred from there in special broadcasting cables to the large transmitter on the Rosenhügel in the southwest of Vienna, as well as to the regional stations in the federal provinces that generated and aired electromagnetic waves at their allocated lengths.

III.3.4 The Social Democrats, who set up about fifty "**freedom celebrations**" opposing the "Turks Deliverance Celebration,"
III.3.5 organized a "**listener strike**" with more than ten thousand cancellations of radio licenses in protest against the live broadcast.³⁰ What these people express in their collective letter of cancellation is an aversion to being patronized by the state and a strong will to raise their own voices on the radio. The protest corresponds to the findings of a contemporary study carried out by the Wirtschaftspsychologische Forschungsstelle, based

28 See "Pfui-Rufe, rote Fahnen und Pfeifkonzert," in: *Die Rote Fahne* (Vienna), May 14, 1933, p. 2.

29 See "Radio-Wochenprogramm vom 13. bis 21. Mai," in: *Neue Freie Presse* (Vienna), May 13, 1933 (evening edition), p. 4.

30 See "Die Antwort auf den Kikeriki-Sonntag," in: *Arbeiter-Zeitung* (Vienna), May 16, 1933, p. 2.

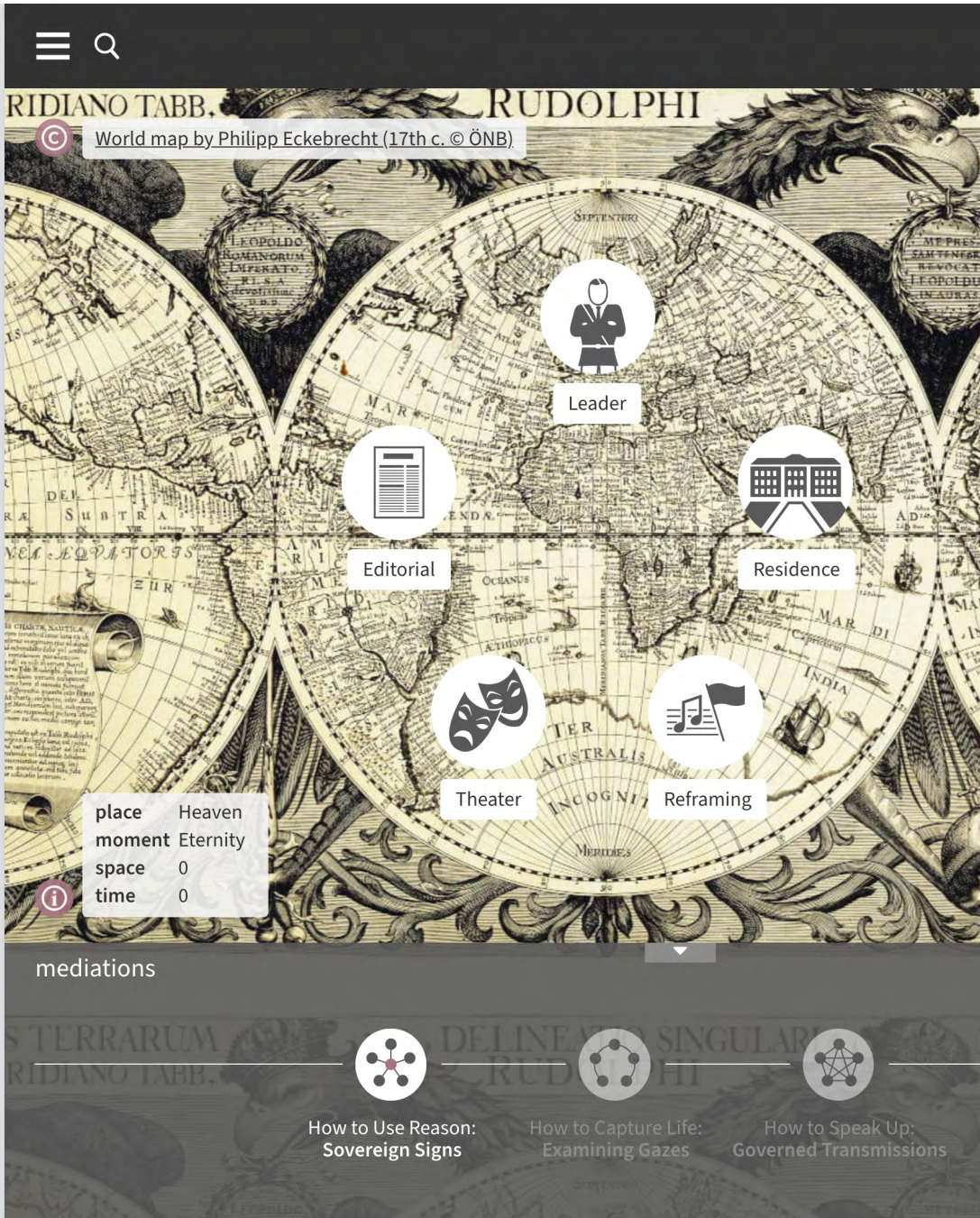

Fig. 5: Screenshot of the Topology module of the website campusmedius.net (desktop version 2.0/2021) showing the start page of the mediation



How to Use Reason: Sovereign Signs

” God

In contrast to the other two mediations, which are implemented without an external perspective, the mediation "How to Use Reason: Sovereign Signs" requires an additional, transcendent mediator. In the website's database, its number is 0 and its name is "God."

“How to Use Reason: Sovereign Signs” (text: Simon Ganahl, code: Andreas Krimbacher, design: Susanne Kiesenhofer).

III.3.2 in Vienna and headed by Paul Lazarsfeld, who later became a major figure in American sociology after his emigration to New York.³¹ The RAVAG had commissioned this Center of Economic-Psychological Research to run a statistical survey of the tastes of Austrian radio listeners. The innovative aspect of the **RAVAG study**, conducted in 1931/32, was not so much the quantitative measurement of listeners' wishes, but rather the fact that it provided information on the likes and dislikes of various social groups. By correlating radio programs with social data, the final report broke down the mass audience into specific target groups. This is one beginning of what is called "profiling" today and what might be appreciated or rejected as **management of the freedom to communicate**.³²

III.3.3 &
Fig. 120, p. 280

3. Data Model and Infrastructure

In the first two parts of this introduction, I mainly discussed the website's front end, i.e., issues related to the interface. On the other side of the software stack, however, its back end is located; invisible to the users, it is a database in which all the content is stored. What I would like to stress here is that deciding which entities are included in the database and how they are related is a genuinely methodological matter. In order to build a scholarly website, the research approach needs to be operationalized; at least working definitions of the central concepts are necessary. In a project within the field of cultural and media studies, this work definitely cannot be conducted by software engineers alone, because: "The database is the theory!"³³ If a website is

- 31 See Desmond Mark (ed.): *Paul Lazarsfelds Wiener RAVAG-Studie 1932. Der Beginn der modernen Rundfunkforschung*, Vienna: Guthmann-Peterson 1996.
- 32 On the history of digital profiling, see Colin Koopman: *How We Became Our Data. A Genealogy of the Informational Person*, Chicago/London: University of Chicago Press 2019, and Andreas Bernard: *The Triumph of Profiling. The Self in Digital Culture*, trans. Valentine A. Pakis, Cambridge: Polity 2019 [German 2017].
- 33 Jean Bauer: "Who You Calling Untheoretical?," in: *Journal of Digital Humanities*, 1/1 (2011), URL: journalofdigitalhumanities.org/1-1/who-you-calling-untheoretical-by-jean-bauer.

Fig. 6, p. 38

supposed to match up to the complexities of the theoretical approaches that are guiding cultural and media research, both its back end and its front end must be developed in a truly interdisciplinary dialogue with programmers and designers. Hence, the following paragraphs will deal with the **data model** on which the Topology module of *Campus Medius* is based.

I start with the entity at the top of the diagram, the *mediator* as anyone or anything given in an experience that makes a difference to the course of action. In our terminology, a *medium* is none other than a type of mediators: Starhemberg appears on the stage of the “Turks Deliverance Celebration” as federal leader of the Austrian Homeland Protection, but ideally aligns himself with leader figures ranging from the Roman Caesars via the Habsburg emperors to the Fascist *Duce*. This is an example of a one-to-many relationship, with one medium constituted from many mediators. It was important for us to attach the attributes *space*, *time*, and *value*—the latter understood in terms of weighing the nodes in a network—to the *relation*, which connects two mediators, and not to the mediator itself.³⁴ The common practice in digital cartography, however, is to determine where and when an entity occurs, i.e., to set its location (latitude/longitude) and its date and time. Yet this approach would have required a kind of transcendent gaze, an external perspective able to situate mediators in absolute time and space. In order to avoid this “god trick of seeing everything from nowhere,”³⁵ we have conceptualized space, time, and value relationally, in other words as differences in the network of mediators.³⁶

- 34 The selection of space, time, and value as relational properties is based on Foucault’s analysis of power relations, especially his precise description of spatial distributions, temporal orders, and evaluative rankings. See Michel Foucault: *Discipline and Punish. The Birth of the Prison*, trans. Alan Sheridan, New York: Vintage Books 1995 [French 1975], pp. 135–228.
- 35 Donna Haraway: “Situated Knowledges. The Science Question in Feminism and the Privilege of Partial Perspective,” in: *Feminist Studies*, 14/3 (1988), pp. 575–599, here p. 581.
- 36 The transcendent position is implemented in the Topology of *Campus Medius* as a deliberate, additional mediator of the mediation “How to Use Reason: Sovereign Signs” (see chap. III.1). In the website’s database, its number is 0 and its name is “God” (see fig. 5, p. 34). The other two mediations are realized immanently, that is, without an external perspective.

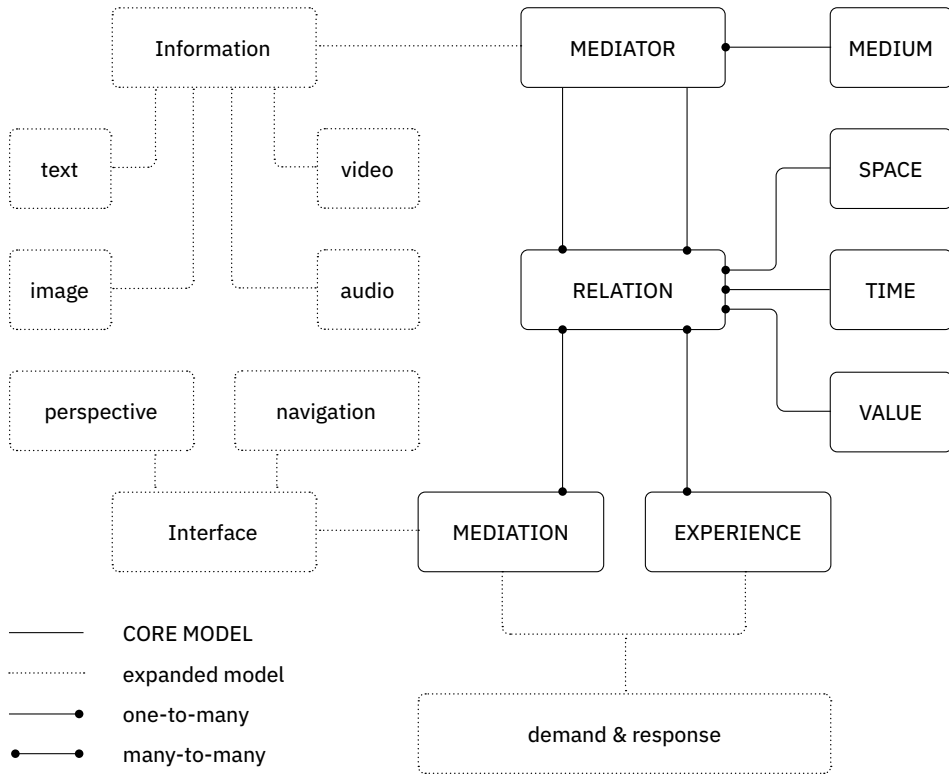

Fig. 6: The data model, developed by Simon Ganahl and Andreas Krimbacher, of the Topology module of the website *campusmedius.net* (version 2.0/2021).

An *experience*, in the sense of our data model, is an individual subset of relations including the attached mediators. And just as in our terminology a medium is a type of mediators, a *mediation* is a pattern of relations (e.g., the centralized topology occurring again and again in the “Turks Deliverance Celebration”). In other words, a regularity of spatial, temporal, and evaluative connections—but what is actually mediated in an experience? This question links to the box at the foot of the data model, which summarizes the major function of the Foucauldian *dispositif*, namely to strategically respond to a social demand.³⁷ While actor-network accounts focus on

37 In an interview from 1977, Foucault defined the *dispositif*, usually translated into English as “apparatus” or “mechanism,” as “a thoroughly heterogeneous →

concrete empirical cases in order to precisely describe who or what makes a difference to a course of action, *dispositif* analysis searches for types of connection, for historical patterns of relations that are actualized in the given situation. Let us take the aforementioned example of the protest against the live broadcast of the “Turks Deliverance Celebration”: the people who canceled their license wanted to speak up and refused to be influenced or educated from above—a collective demand to which Austrian radio was not ready to respond in 1933. However, counseled by the emigrant Paul Lazarsfeld, his wife Herta Herzog, and his friend Hans Zeisel, the Columbia Broadcasting System (CBS) and the New York advertising agency McCann-Erickson soon learned how to steer free expression of opinion in specific directions.³⁸

In short, the actor-network and the *dispositif* are the central theoretical concepts that are operationalized in the data model of *Campus Medius* 2.0. Thus far, I have only elaborated on the right-hand part of the **diagram**, the ontological structure of the database. Its left-hand side, however, shows how the stored data become perceptible to the users. In order to appear on the website, a mediator (or an event in the Topography module) needs to receive *information*—it literally has to be *informed* by texts, images, audio, or video. The **metadata** of these multimedia descriptions can be accessed via the quote icon next to each page title and downloaded as linked open

Fig. 6, p. 38

Fig. 29, p. 80 &
Fig. 30, p. 84

Fig. 9, p. 42

- ensemble [*un ensemble résolument hétérogène*]” and explicitly as “the network [*le réseau*] that can be established between these elements,” comprising “the said as much as the unsaid.” He emphasized, however, that he is not so much interested in categorizing the connected entities, for example as discursive or material, but rather in searching for the specific “nature of the connection [*la nature du lien*].” Foucault added that every *dispositif* “answers an urgent demand [*répondre à une urgence*]” by strategically solving a social problem. (Michel Foucault: “The Confession of the Flesh,” trans. Colin Gordon [French 1977], in: *Power/Knowledge. Selected Interviews and Other Writings 1972–1977*, ed. Colin Gordon, New York: Pantheon 1980, pp. 194–228, here pp. 194–195 [trans. modified].)
- 38 See Paul F. Lazarsfeld: “An Episode in the History of Social Research. A Memoir” [1968], in: Patricia L. Kendall (ed.): *The Varied Sociology of Paul F. Lazarsfeld*, New York: Columbia University Press 1982, pp. 11–69.

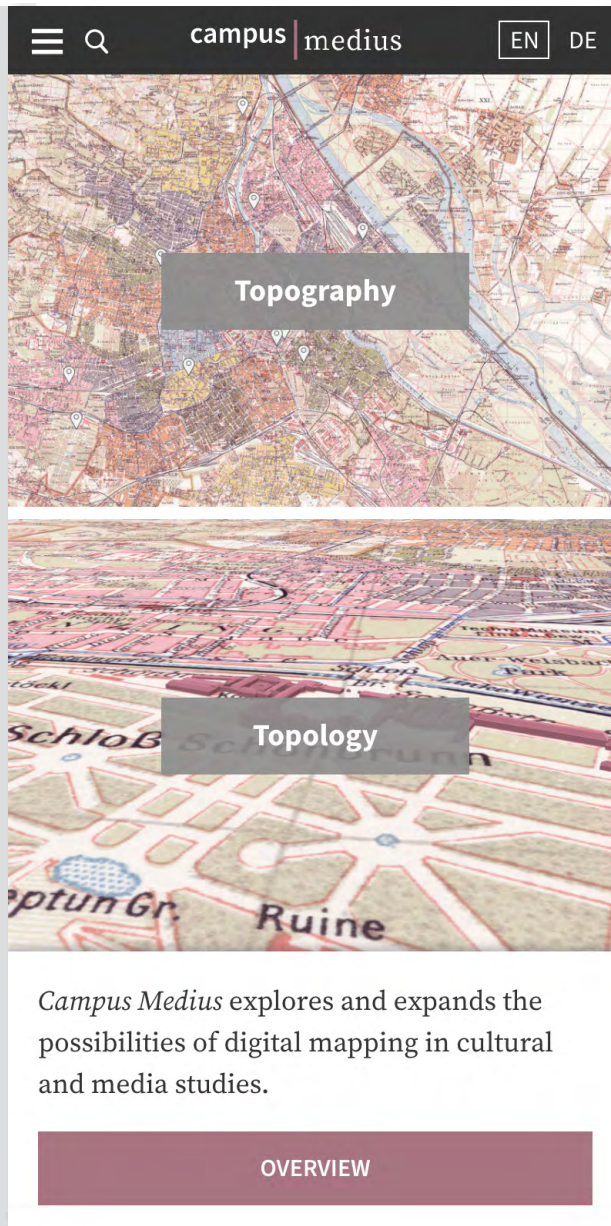

Fig. 7: Screenshot of the website [campusmedius.net](https://www.campusmedius.net) (mobile version 2.0/2021) showing the start page with the selection of the page “Overview” (text: Simon Ganahl, code: Andreas Krimbacher, design: Susanne Kiesenhofer).



Fig. 8: Screenshot of the website campusmedius.net (mobile version 2.0/2021) showing the start page of the Topology module (text: Simon Ganahl, code: Andreas Krimbacher, design: Susanne Kiesenhofer).

Citation Simon Ganahl: "Schönbrunn Palace Gardens," trans. by Katy Derbyshire, last modified on August 15, 2021, in: Simon Ganahl et al.: *Campus Medius*, 2014–2021, URL: <https://campusmedius.net/topography/events/10?lang=en&info=full> ([copy](#)) ✕

Title "Schönbrunn Palace Gardens" in *Campus Medius*

URL <https://campusmedius.net/topography/events/10?lang=en&info=full> ([copy](#))

Text [Simon Ganahl](#)

Translation [Katy Derbyshire](#)

Code [Andreas Krimbacher](#)

Design [Susanne Kiesenhofer](#)

Published July 10, 2014

Updated August 15, 2021

Abstract On Sunday morning, May 14, 1933, ... ([show all](#))

Keywords 1683, 1933, Adolf Hitler, ... ([show all](#))

Copyright This website is licensed under Creative Commons Attribution 4.0 ([CC BY 4.0](#)). This license permits unrestricted use and distribution of the respective material, provided that the creator(s), who retain(s) copyright, and the source are properly credited, ideally in the form suggested above. The reuse of works cited on this website from external sources (texts, images, audio, video) may require further permissions from the rights holder(s). The obligation to research and obtain such permissions lies with the reusing party.

Funding Based on international peer reviews, the production of this website has been supported by the Austrian Academy of Sciences ([ÖAW](#): APART 11810), the Austrian Science Fund ([FWF](#): J 3181-G20 & PUD 17-G), the City of Vienna ([MA 7](#): 573323/14), the [Department of German Studies](#) at the University of Vienna, and the digital repository [Phaidra](#).

 [Download metadata in JSON-LD format](#)

Fig. 9: Screenshot of the website campusmedius.net (desktop version 2.0/2021) showing the metadata of the event "Schönbrunn Palace Gardens" in the Topography module (text: Simon Ganahl, code: Andreas Krimbacher, design: Susanne Kiesenhofer).

Dollfuss
🔍

📄

Schönbrunn Palace Gardens

All three politicians—Fey, Starhemberg, and [Dollfuss](#)—appear as speakers at the "Turks Deliverance Celebration." In his address, Fey recalls the genealogical line [...]

[...] infiltrated the nation. Foreign spirit and foreign ideas," [Dollfuss](#) says, "have infected our people, and wreaked evil havoc." The aim, he states, is to "eradicate the red flood [...]

1 more on this page

[...] for propaganda purposes to Federal Chancellor Engelbert [Dollfuss](#) and secured financial support from Benito Mussolini, Italy's Fascist prime minister. After Adolf Hitler had [...]

🖼️

[...] photograph of Ernst Rüdiger Starhemberg (left) and Engelbert [Dollfuss](#), which was taken at the "Turks Deliverance Celebration" (Türkenbefreiungsfeier) on the garden terrace of [...]

🗣️

[...] To welcome our front comrade, Federal Chancellor [Dollfuss](#), as comrades." [Our translation.] Then Engelbert [Dollfuss](#) addresses the crowd: "When you celebrate this day [...]

📄

Ernst Rüdiger Starhemberg

[Dollfuss](#) also commemorated the historical events of 1683, yet he emphasized not only Count von Starhemberg but also the [...]

[...] memoirs, that established his friendship with Engelbert [Dollfuss](#), then federal chancellor of Austria. However, when he dictated these memories to his secretary in the winter of [...]

9 more on this page

🖼️

Engelbert [Dollfuss](#) (in front of the microphones) and Ernst Rüdiger Starhemberg (behind him) on the garden terrace of Schönbrunn Palace [...]

🖼️

[...] federal government and their leaders, including Engelbert [Dollfuss](#) (second from left) and Ernst Rüdiger Starhemberg (third from left), who review and salute the paramilitary [...]

1 more on this page

Fig. 10: Screenshot of the website campusmedius.net (desktop version 2.0/2021) showing the first results of a full-text search for the name "Dollfuss" (text: Simon Ganahl, code: Andreas Krimbacher, design: Susanne Kiesenhofer).

<https://doi.org/10.14381/9783838468019> <https://www.kitlibra.com/de/legb> - Open Access -

Fig. 10, p. 43

data.³⁹ The content is **full-text searchable** and available open access under the Creative Commons license CC BY 4.0,⁴⁰ apart from the works cited in *Campus Medius*, which are protected by copyright. The typefaces used on the website are open-source fonts, namely *Source Sans Pro* by Paul D. Hunt and *Source Serif Pro* by Frank Griesshammer.

Just like a mediator without information, a mediation—in the sense of our data model—stays invisible as long as there is no link to an *interface*, understood here as a mapping perspective (e.g., bird’s-eye) and a mode of navigation (e.g., zooming). Hence, these visualizations are not neutral or free of ideology, but themselves part of their respective *dispositif* of mediation. In common with the substructure of *campusmedius.net*, they were programmed with open-source software: the front end in Angular and Mapbox GL JS, the back end in Django using a PostgreSQL database. The project code is fully documented and freely available under the MIT license at GitHub.⁴¹ We have implemented the website bilingually and responsively, that is, in English and in German, as well as for both desktop and **mobile use**. It runs on a virtual server provided by the Vienna University Computer Center with all its data archived in the digital repository PHAIDRA.⁴²

Fig. 7, p. 40 &
Fig. 8, p. 41

4. Mapping Modern Media

In the last part of the introduction, I will sketch out the long-term plans that we are pursuing for *campusmedius.net*. We want to develop the website into a digital platform for mapping

- 39 The metadata include title, URL, abstract, keywords, authors, dates of publication and of last modification, and details on copyright and funding. They are modeled on the vocabulary of Schema.org and encoded in JSON-LD format (URL: [json-ld.org](https://www.json-ld.org/)).
- 40 This license permits unrestricted use and distribution of the respective material, provided that the creator(s), who retain(s) copyright, and the source are properly credited. See URL: creativecommons.org/licenses/by/4.0/deed.en.
- 41 See URL: github.com/campusmedius/campusmedius.
- 42 See URL: phaidra.univie.ac.at.

media experiences. Guided by a virtual assistant, the users may independently select a media experience in their daily lives, precisely describe its heterogeneous components, and map how these mediators are connected with each other. The analytical aim of the platform would be to subject the conceptual premises of the historical case study to a contemporary test: does having a media experience in the (post) modern societies of the twenty-first century still mean using reason in sovereign signs, capturing life in examining gazes, or speaking up in governed transmissions? In the case of the “Turks Deliverance Celebration,” these *dispositifs* of mediation arose from an interplay between the empirical material and a Foucauldian theory of modernity.⁴³ I want to highlight the word *interplay* in the sense of a mutual dialogue here, because data do not explain themselves, but it also leads nowhere to obey a theoretical system that degrades them to mere placeholders. However, we are confident that our data model enables us to define media and mediations immanently, so to say from below, by analyzing numerous mappings of media experiences in order to discover types of mediators and relational patterns that are distinctive of mediality as a (post)modern field of experience.

The idea for this collaborative platform evolved from courses on “Mapping Modern Media,” which I have taught at different universities since 2016. Instead of geo-referencing data sets, the students are encouraged to consider mapping as a critical practice by selecting and inquiring into media experiences in their daily lives: Who or what is given in such a course of action? How are these mediators connected with each other? To which demand is the media experience responding? And what might an alternative response be? For these courses, the data model of *Campus Medius* 2.0 had to

- 43 Foucault did not actually formulate such a theory, but in the lectures on governmentality he summarized his studies on modernity and adjusted his approach. Instead of defining epochal shifts around 1650 and 1800, he conceptualized a sovereign, a disciplinary, and a liberal regime, which can all be traced from the seventeenth up to the twentieth century. See Michel Foucault: *Security, Territory, Population. Lectures at the Collège de France 1977–1978*, trans. Graham Burchell, ed. Michel Senellart, Basingstoke: Palgrave Macmillan 2007 [French 2004], esp. pp. 87–114.

be translated into a series of practical operations or rather mapping exercises.

1. *Select*: What do you regard as a media experience? Choose a concrete situation, a course of action that plays a role in your everyday life, and give reasons for your choice.
2. *Inventory*: Who or what is given in this media experience and actually makes a difference? Pick five mediators and describe the course of action from these different perspectives.
3. *Visualize*: How are the mediators connected in terms of space, time, and value? Map the spatial, temporal, and evaluative relations of the media experience.
4. *Analyze*: What drives this course of action? To which urgent demand is the media experience responding? Observe and think deeply, then explain its leitmotif.
5. *Critique*: Can you imagine another response to this demand? Which mediators are involved? How are they linked? Create a counter-map showing an alternative mediation.

The exercise starts by selecting a concrete situation in everyday life that could be classified as a media experience and by explaining this choice. In the inventory, step two, the students are asked to define five mediators and to describe the selected course of action from these heterogeneous standpoints. The actual mapping follows in a third step where charts or diagrams are created that visualize the relations between the mediators. I encourage the students to explore the connections in terms of space, time, and value, but it is not strictly necessary for all three perspectives to be represented. Steps four and five are intended to be a critique of the analyzed situation: after contemplating to which urgent demand the media experience is responding, identifying its leitmotif, an alternative response or answer should be given in the form of a counter-map.⁴⁴ One student of mine chose to look into her habit of watching

44 On critique as the “art of not being governed quite this way,” see Michel Foucault: “What is Critique?,” trans. Lysa Hochroth [French 1978], in: *The Politics of Truth*, ed. Sylvère Lotringer, Los Angeles: Semiotext(e) 2007, pp. 1–81, here p. 45 [trans. modified]. On critical cartography and counter-mapping, see Jeremy W. Crampton and John Krygier: “An Introduction to Critical Cartography,” in: *ACME. An International E-Journal for Critical* →

Tatort, for example, a very popular crime series produced and aired by public service broadcasters in Germany, Austria, and Switzerland. She asked herself why she views this TV drama almost every Sunday evening and concluded that she mainly appreciates the sense of community, knowing that millions of other viewers see and hear the same program at the same time. Yet if the “sense of community” is the real motive behind this media experience, what alternatives are there to feel in touch with others? Does it have to be a community of people with a similar language and cultural background (as in the case of *Tatort*)? Or could it also be a collective assembling more diverse members?

In conclusion, I will present some works created in these mapping courses. The first example was made by a student from UCLA’s Center for Digital Humanities who mapped the movement of the hose in a hookah session with five people sharing a water pipe, which he described as an opportunity to have easygoing conversation. One of his classmates in this course from 2016 constructed a timeline of unboxing an iPhone in an Apple Store, treated like a spiritual rite, and defined two points of no return: the removal of the plastic around the box and of the phone’s screen protector. In a class on sound mapping held at the University of Liechtenstein in 2016, one student charted how his daily activities were influenced by pupils playing in a schoolyard near his office. Another participant in this seminar temporally arranged photos in order to visualize how he was woken every morning by a passing train.

Fig. 13, p. 50

At the University of Applied Sciences (FH) in Vorarlberg, Austria, a student of media design drew a **timeline of preparing espresso** on the stove, a procedure that seemed to organize her morning routine into a phase of personal hygiene while the coffee is brewing, and a phase of calm me-time before the workday begins. One of her classmates in this course from 2017 had a **blood sample** taken from a peripheral vein and represented this physical intervention in a series of sketches.

Fig. 11, p. 49

→ *Geographies*, 4/1 (2005), pp. 11–33, URL: www.acme-journal.org/index.php/acme/article/view/723, and the inspiring “critical cartography primer” in Annette Miae Kim: *Sidewalk City. Remapping Public Space in Ho Chi Minh City*, Chicago: University of Chicago Press 2015, pp. 112–145.

Fig. 12, p. 49

As she concluded that a need for self-assurance drove this experience, her counter-map shows an examining **look in the mirror**. The next year, 2018, the design students at the FH Vorarlberg created, for instance, a visual discourse analysis of an advertising brochure, a video documentation of selecting a selfie on the phone, a diagram of walking the dog with a leash, and a visualization of viewing a photographic exhibit.

Fig. 15, p. 51

The following examples spring from a course in 2019, which I again held at the University of Liechtenstein. In this class, a student of architecture dealt with her **daily entries in a sketch book**. As an alternative approach to her attempt to build a personal archive of architectural forms, she mapped photographs that were taken on study trips. Another participant in this seminar described and visualized the morning shower as a mediation between the privacy of the bed and the public life of work. His counter-map then addressed **car driving** as a means of commuting from one place to another, but also as a situation where the mind oscillates between concentration and memories or dreams.

Fig. 14, p. 50

Fig. 16, p. 51

The student projects of 2020 were strongly shaped by the changed living situation that arose from the coronavirus pandemic. On the one hand, they were concerned with the digitization of workflows as in the case of an architecture student who observed her **fidgiting in videoconferences** and represented this “restless energy” in a timeline. On the other hand, there were several attempts to structure the course of the day while staying at home, for example, by **meditating**, watering plants, or medicating the cat according to a fixed schedule. As stated by the students, the projects mentioned here revolve around communication processes, partly between different humans via technological devices, partly addressed to oneself, to flowers, or to pets.

Fig. 17, p. 52

All in all, these courses and workshops are quite experimental, a kind of laboratory to develop our digital mapping platform that also aims to serve media education. Analytically, the major challenge is to define a clear methodological procedure without predetermining what counts as a media experience. We want to collaboratively map the *campus medius*, the field of media, whether the course of action be taking a selfie or walking the dog. In spite of this openness regarding

content, the results have to be comparable so that a multitude of mappings may disclose media as types of mediators and mediations in the sense of relational patterns.

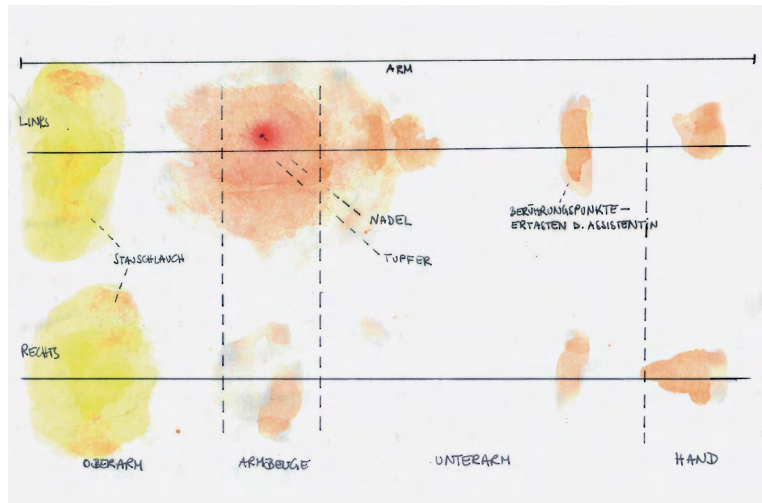

Fig. 11: Astrid Neumayr: Diagram of a venipuncture, created in a course taught by Simon Ganahl at the Vorarlberg University of Applied Sciences in 2017.

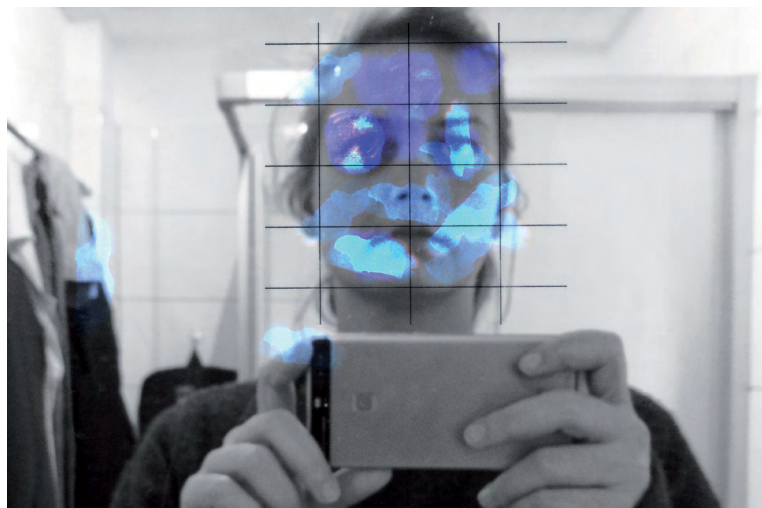

Fig. 12: Astrid Neumayr: Representation of looking in the mirror, created in a course taught by Simon Ganahl at the Vorarlberg University of Applied Sciences in 2017.

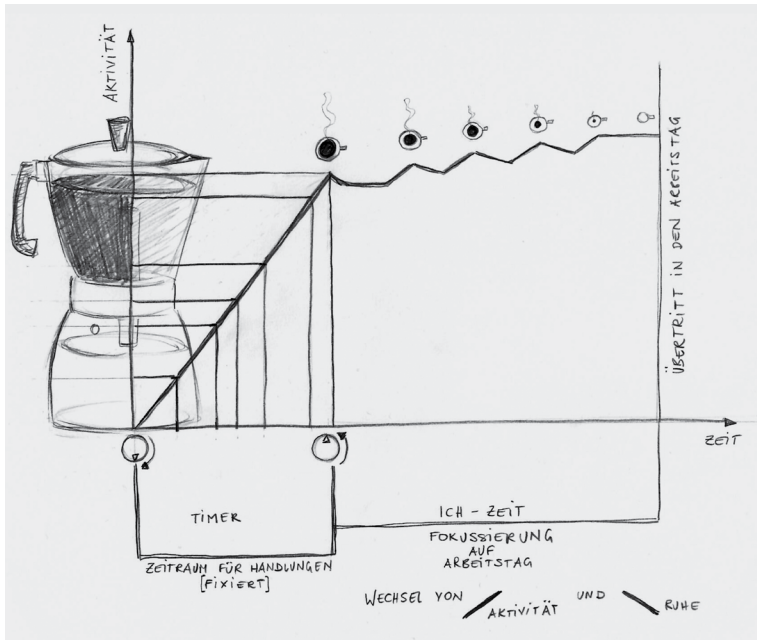

Fig. 13: Alexandra Kraller: Timeline of making espresso, created in a course taught by Simon Ganahl at the Vorarlberg University of Applied Sciences in 2017.

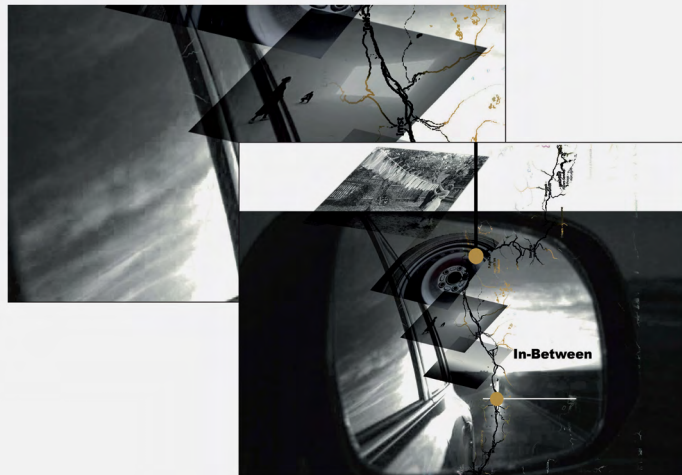

Fig. 14: David Juen: Map of a car ride, created in a course taught by Simon Ganahl at the University of Liechtenstein in 2019.

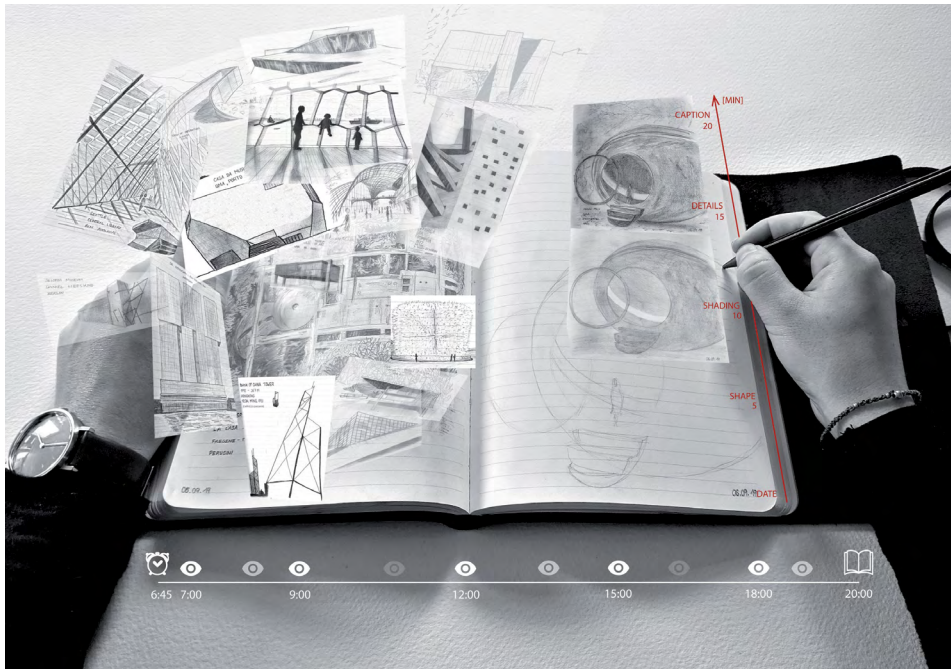

Fig. 15: Lina Gasperi: Visualization of an entry in the sketch book, created in a course taught by Simon Ganahl at the University of Liechtenstein in 2019.

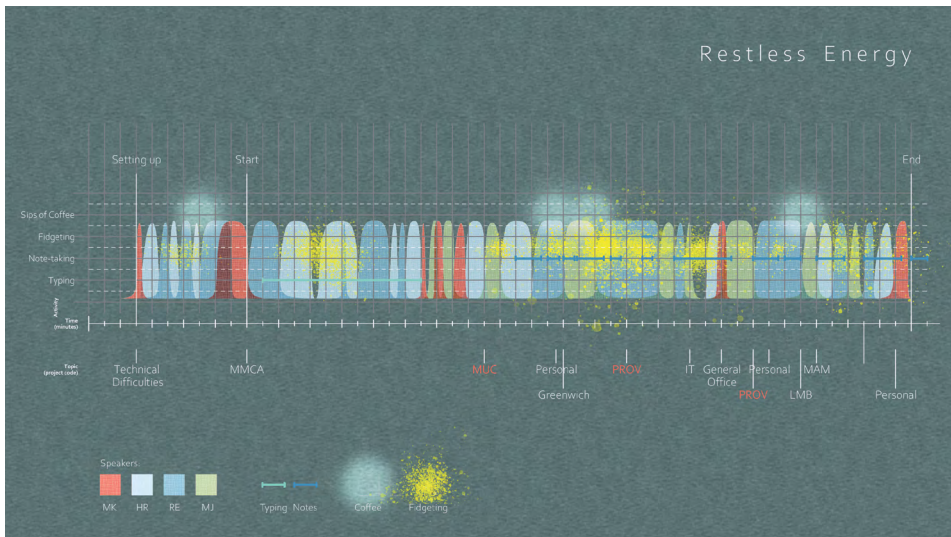

Fig. 16: Mio Kobayashi: Timeline of a videoconference, created in a course taught by Simon Ganahl at the University of Liechtenstein in 2020.

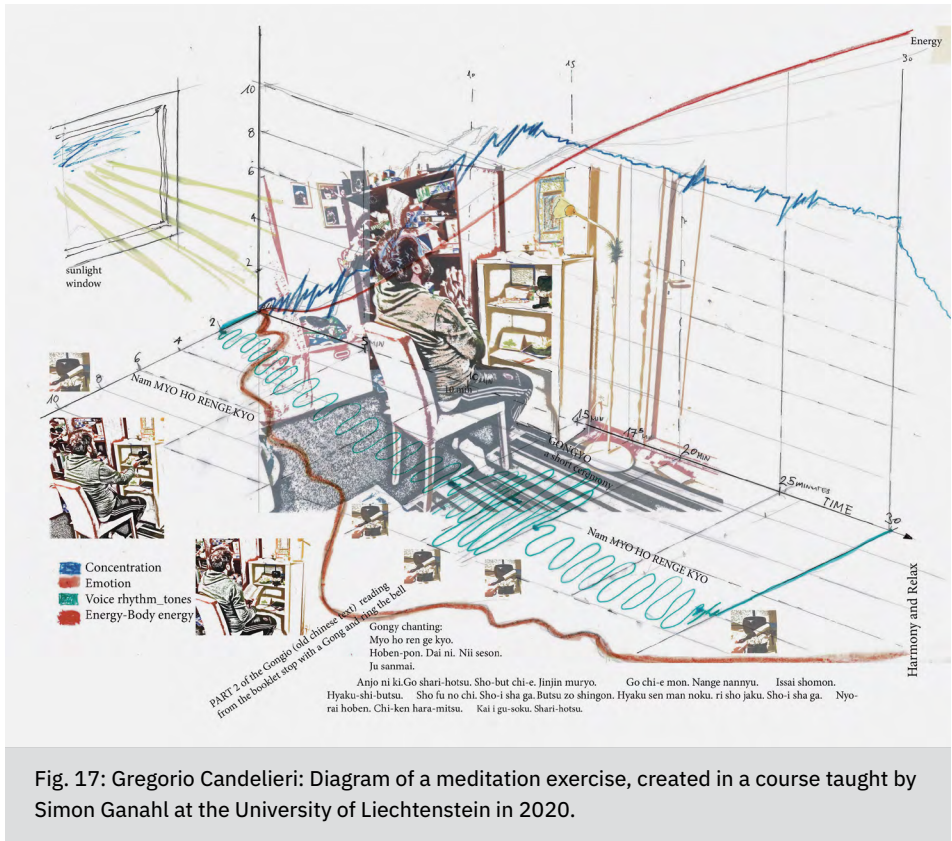

Fig. 17: Gregorio Candelieri: Diagram of a meditation exercise, created in a course taught by Simon Ganahl at the University of Liechtenstein in 2020.

Topography:
An interactive map
with a timeline
displaying fifteen
events within
twenty-four hours
in Vienna on the
weekend of May 13
and 14, 1933.

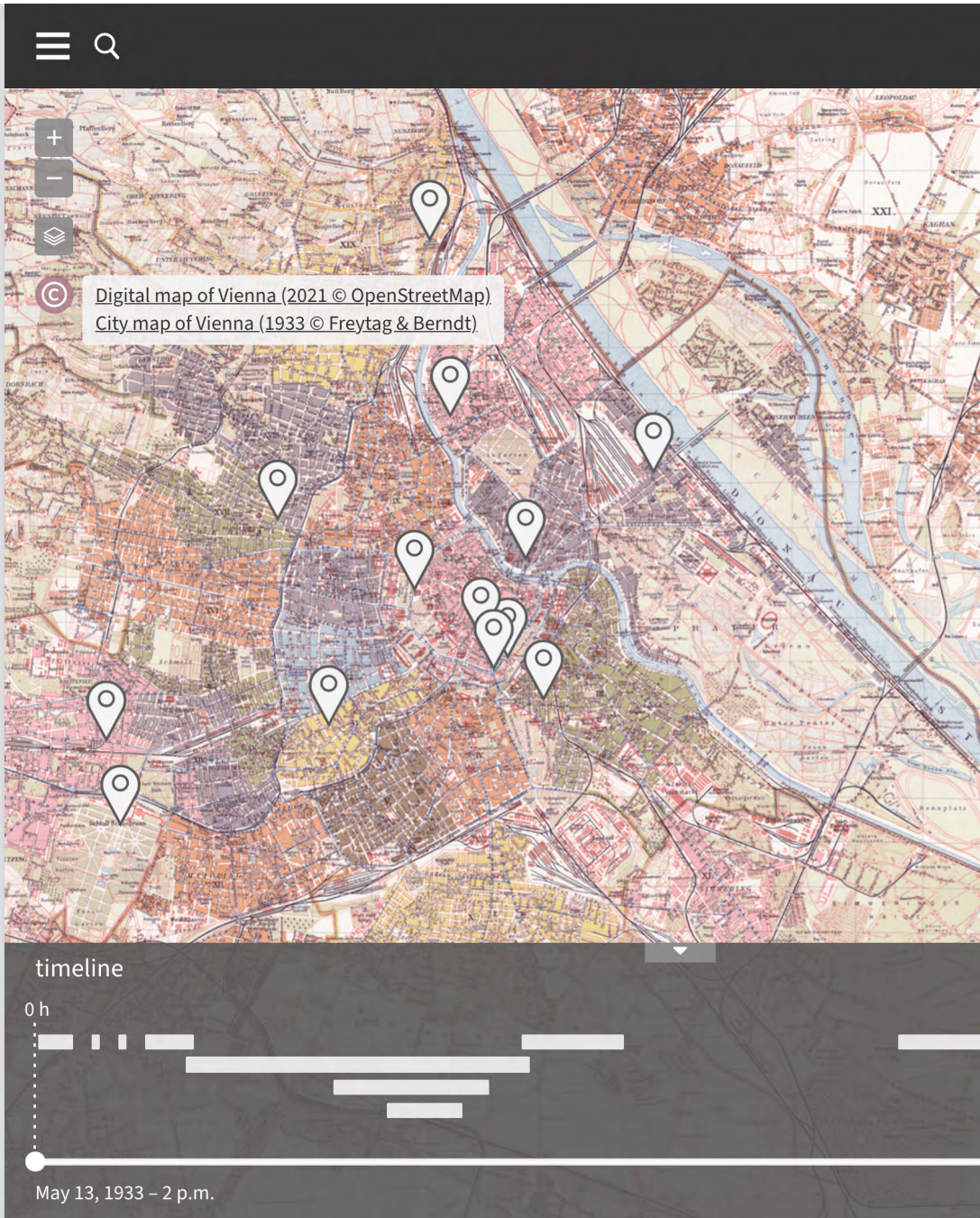
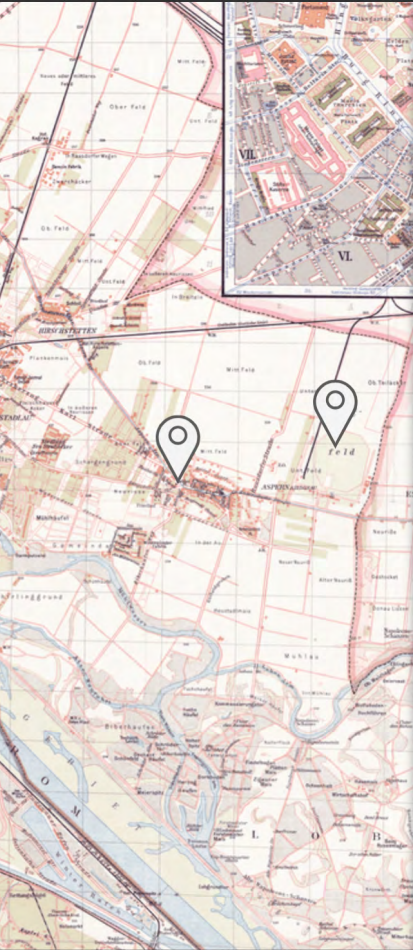

Fig. 18: Screenshot of the website campusmedius.net (desktop version 2.0/2021) showing the start page of the Topography module (text: Simon Ganahl, code: Andreas Krimbacher, design: Susanne Kiesenhofer).



Topography

The Topography of *Campus Medius* consists of an interactive map with a timeline displaying fifteen events within twenty-four hours in Vienna on the weekend of May 13 and 14, 1933. This exemplary time-space is marked by a "Turks Deliverance Celebration" (*Türkenbefreiungsfeier*), which the Topology module imparts from multiple perspectives.

START

24 h

May 14, 1933 – 2 p.m.

The QR code leads
to the corresponding
web page.



1. Aspern Airfield



place Gross-Enzersdorfer Strasse, XXI Floridsdorf⁴⁵
 time May 13, 1933, 2:00 p.m. to 2:45 p.m.

Fig. 19, p. 57

At 2:12 p.m. on Saturday, May 13, 1933, the German Lufthansa plane **D 1772** lands at Aspern airfield in Vienna.⁴⁶ Having taken off three and a half hours previously in Berlin, the plane's passengers are the Bavarian Minister of Justice Hans Frank, who would become governor-general of occupied Poland in 1939, his Prussian counterpart Hanns Kerrl, and Kerrl's Head of Department Roland Freisler, the later president of the German People's Court of Justice, along with a handful of accompanying staff. Some 1,500 followers and a crowd of press reporters and photographers await the National Socialist politicians.

III.1.2 &
 Fig. 42, p. 117

The Vienna *Reichspost*, the semiofficial newspaper of Austria's Christian Social Party, had referred to the visit in a controversial **editorial** as "undesirable and unwelcome." Firstly, the leading article considered it not a state visit but a "party-political battle action," and secondly the delegation leader was a persona non grata in Austria.⁴⁷ Hans Frank had held a speech on Bavarian radio on March 18, 1933, which prompted diplomatic conflicts. According to a report from the Wolff Telegraphic Bureau, Germany's official news agency, the Bavarian minister of justice warned the Austrian government against "giving the National Socialists occasion to protect the freedom of their fellow Germans in Austria."⁴⁸

In Germany, a cabinet under Adolf Hitler had been in office since January 30, 1933, and considered itself responsible for all "German national comrades," whether they lived within

45 Today XXII Donaustadt.

46 See "Die Ankunft der reichsdeutschen Nationalsozialisten," in: *Das Kleine Volksblatt* (Vienna), May 14, 1933, p. 4.

47 "Unerwünschter Besuch," in: *Reichspost* (Vienna), May 9, 1933, pp. 1–2 [our trans.].

48 Cit. after a memorandum of March 22, 1933, in the Political Archive of the Federal Foreign Office in Berlin (Office of the Reich Minister, reference 16: Austria, R 28392) [our trans.].



Fig. 19: Hans Frank (on the right) and Hanns Kerrl (in the middle) are welcomed by Alfred Eduard Frauenfeld (on the left) at Aspern airfield in Vienna shortly after 2 p.m. on May 13, 1933. The smiling man in the background is Roland Freisler. Source: Austrian National Library, Pz 1933 V 13/1/1C(D).

or outside the German borders. The Christian Social federal chancellor of Austria, Engelbert Dollfuss, however, wanted to preserve the country as a sovereign German state and had been governing by emergency decree since March 1933. When the Nazi politicians arrive in Aspern, the vice president of the Vienna police department, Michael Skubl, approaches them and informs them in the name of the Austrian government that their visit is “not desired,” but that their personal safety will be secured.⁴⁹ The visitors from Germany then drive into the city in a motorcade of dozens of cars and motorcycles to the **Adolf Hitler House**, the National Socialist party headquarters in Vienna.

II.4

The *Reichspost* editorial emphasized that “the measures Austria must take on this occasion” were targeted “neither at the Reich government nor against members of a German state government, but exclusively at the attempt by foreign guests to give new stimulus to subversive and antigovernmental agitation within our own borders.” Hitler, the article stated, had shown a “high degree of discretion and moderation” in international politics. “The question thus remains open as to whether he is in agreement with this journey of party-political agitation by high-ranking state officials.”⁵⁰ According to this semiofficial commentary, the reserved reception at Aspern airfield was not due to any fundamental criticism of National Socialism in Germany. The Austrian government did, however, want to prevent the Nazi opposition in Austria from receiving an opportunity for political propaganda.

49 “Die Ankunft der reichsdeutschen Nationalsozialisten” [our trans.].

50 “Unerwünschter Besuch,” p. 2 [our trans.].

2. Lion of Aspern



place Heldenplatz, XXI Floridsdorf⁵¹
 time May 13, 1933, 3:00 p.m. to 3:15 p.m.

II.1 On the way from **Aspern airfield** into the city, the motorcade with Nazi politicians from Germany halts at the Lion of Aspern. Built in 1858, this war memorial is dedicated to the fallen soldiers of the 1809 Battle of Aspern, where Austrian troops were victorious over Napoleon's army for the first time. After Bavarian Minister of Justice Hans Frank and his Prussian counterpart Hanns Kerrl lay wreaths, Alfred Eduard Frauenfeld, the Nazi gau administrator (*Gauleiter*) of Vienna, holds a short speech. A day later, the *Deutschösterreichische Tages-Zeitung*, the National Socialists' official newspaper in Austria, reports: "They thereby honored the German-Austrian freedom fighters of 1809, the first Germans to tear the victory laurels from the head of the French usurper, but also all victims of the World War."⁵² The motorcade continues on toward Hirschstetten and Kagran.

Fig. 20, p. 58



Fig. 20: Hans Frank lays a wreath at the Lion of Aspern in Vienna at around 3 p.m. on May 13, 1933, printed in *Deutschösterreichische Tages-Zeitung* (Vienna), May 21, 1933, pictorial supplement, p. 348. Source: Austrian National Library, 395201-D.

51 Today Asperner Heldenplatz, XXII Donaustadt.

52 "Triumphzug durch die Strassen," in: *Deutschösterreichische Tages-Zeitung* (Vienna), May 14, 1933, p. 3 [our trans.].

3. Lassalle Hof



place Lassallestrasse 40–44, II Leopoldstadt
time May 13, 1933, 3:30 p.m. to 3:45 p.m.

In the Leopoldstadt, Vienna's second municipal district, the
II.1 Nazi politicians from Germany driving from **Aspern airfield**
II.4 to the **Adolf Hitler House** in a motorcade encounter left-wing
protest. As the cars and motorcycles cross the Reichsbrücke
bridge, whistles and boos sound out. The residents of the **mu-**
nicipal public housing (*Gemeindebau*) at Lassallestrasse 40–44,
red flags flying from its windows and balconies, air their
views openly:

Fig. 21, p. 60

III.2.5 *From the Lassalle Hof, which had been cordoned off by the police, the workers looked down from their windows, but from the back. Body parts were visible that the Nazi ministers were supposed to understand as a call to make the **Götz quote** a reality.⁵³*

To avoid further conflict, the police alter the route. The German visitors are not allowed to drive along Praterstrasse and the Ring as planned, but have to take Franzensbrückenstrasse from the Praterstern and continue along Löwengasse, the so-called Lastenstrasse, and Gumpendorfer Strasse, where neither supporters nor opponents await them.⁵⁴

Fig. 105, p. 245
III.3.4 The **Lassalle Hof** was built from 1924 to 1926 and designed by the architect Hubert Gessner, a student of Otto Wagner. It was one of the first major public housing projects erected in the “**Red Vienna**” of the interwar years. The architecture historian Eve Blau writes about these residential complexes:

- 53 “Pfui-Rufe, rote Fahnen und Pfeifkonzert,” in: *Die Rote Fahne* (Vienna), May 14, 1933, p. 2 [our trans., emphasis added]. The Götz quote was coined by Johann Wolfgang Goethe in his drama *Götz von Berlichingen mit der eisernen Hand* (1773, p. 133): “Tell your captain: For His Imperial Majesty I have as ever due respect. But he, tell him, he can lick me in the ass.” [Our trans.]
- 54 See “Die nationalsozialistischen Fluggäste aus Deutschland,” in: *Reichspost* (Vienna), May 14, 1933, p. 8.



Fig. 21: Hans Frank (in the back of the car) driving by the Lassalle Hof in Vienna at around 3:30 p.m. on May 13, 1933, printed in *Die Stunde* (Vienna), May 16, 1933, p. 3. The text reads: “The ‘Undesirable Visit’ / Minister Frank and his companions return the ‘greetings’ of the red-flagged Lassalle Hof.” Source: Austrian National Library, 606233-D.

For the Social Democrats, who came to power in Vienna in 1919 and governed Austria’s capital until 1934, the construction program with over 400 new municipal constructions, which had to be inserted between Vienna’s existing buildings, formed the core of extensive reform plans for redesigning the city’s social and economic infrastructure according to socialist principles.⁵⁵

Named after Ferdinand Lassalle, a pioneer of the German workers’ movement, the building comprised 290 apartments spread across six stories. On the ground floor facing Lassallestrasse were shops and a public library. The top floor of the tower above the main building was used as a photography studio by the Social Democratic association Friends of Nature (*Naturfreunde*).⁵⁶ Located between the Reichsbrücke and the Praterstern, the monumental Lassalle Hof still dominates one of Vienna’s northeastern arterial roads today.

55 Eve Blau: “Wien 1919–1934. Grossstadt und Proletariat im ‘Roten Wien,’” in: Eve Blau and Monika Platzer (eds.): *Mythos Grossstadt. Architektur und Stadtbaukunst in Zentraleuropa 1890–1937*, Munich: Prestel 1999, pp. 205–214, here p. 205 [our trans.].

56 See *Lassalle-Hof. Die Wohnhausanlage der Gemeinde Wien im II. Bezirk*, ed. Wiener Stadtbauamt, Vienna: Reisser [1926], pp. 5–8.

4. Adolf Hitler House



place Hirschengasse 25, VI Mariahilf
time May 13, 1933, 4:00 p.m. to 5:00 p.m.

Fig. 22, p. 61

- The Nazi politicians from Germany arrive at the Adolf Hitler House at around 4 p.m. The motorcade from **Aspern airfield** was diverted at the Praterstern. As hundreds of supporters have waited in vain on **Mariahilfer Strasse**, the visitors drive a few laps around the party headquarters at Hirschengasse 25.⁵⁷ Despite rain showers, the National Socialists still line the streets to welcome their party leaders with salutes and shouts of “Heil Hitler!” As at the **Lassalle Hof** earlier, altercations with political opponents ensue. “The police had to make use of truncheons to clean the streets,” reports the *Wiener Zeitung*, the official newspaper of the Austrian federal government.⁵⁸
- II.1
- II.3
- III.1.2 According to the Christian Social *Reichspost*, “fifty National Socialists and thirty-six Social Democrats” are arrested in the course of the afternoon for disturbing the peace, violence, or insulting police officers.⁵⁹



Fig. 22: A motorcade on the occasion of German Nazi politicians visiting Vienna on May 13, 1933, here on Mariahilfer Strasse at around 4:30 p.m. Source: Municipal and Provincial Archives of Vienna, 2.7.1.11.1.FC1.1.233.

- 57 See “Die nationalsozialistischen Fluggäste aus Deutschland,” in: *Reichspost* (Vienna), May 14, 1933, p. 8.
- 58 “Reichsdeutscher Besuch bei den Nationalsozialisten,” in: *Wiener Zeitung* (Vienna), May 14, 1933, p. 6 [our trans.].
- 59 “Die nationalsozialistischen Fluggäste aus Deutschland” [our trans.].

The building at Hirschengasse 25 had come into the ownership of the Vienna NSDAP on October 14, 1931. It was officially named Adolf Hitler House but referred to in the press as the “Brown House.” SS men lived close to the party headquarters and there was also an SA hostel nearby. The choice of location was provocative, because the district was not only regarded as a “cradle of the workers’ movement,”⁶⁰ but was also a center of the Jewish community in the districts of Mariahilf and Neubau. Until 2019 the former Adolf Hitler House was a youth hostel for students from other parts of Austria, who visited Vienna on traditional group trips to the capital.

5. UFA Ton Kino



place Taborstrasse 8, II Leopoldstadt
time May 13, 1933, 4:45 p.m. to 11:15 p.m.

Fig. 23, p. 63

Fritz Lang’s sound film *Das Testament des Dr. Mabuse* (*The Testament of Dr. Mabuse*) is screened in **eight movie theaters in Vienna** on Saturday evening, May 13, 1933. The UFA Ton Kino at Taborstrasse 8 shows the two-hour production by the Berlin Nero Film AG at 4:45, 7:00, and 9:10 p.m.⁶¹ Joseph Goebbels, the National Socialist propaganda minister, viewed the crime film on March 28, 1933, and demanded it be banned in Germany, which took place the following day. *The Testament of Dr. Mabuse* was a “danger to the state,” according to the minutes of the censorship meeting, because the crimes it portrays could be used as a “textbook for preparing and committing acts of terrorism.”⁶² The world premiere was

60 Christiane Rothländer: “Das ‘Adolf-Hitler-Haus’ in der Hirschengasse 25, Mariahilf,” in: Kilian Franer and Ulli Fuchs (eds.): *Erinnern für die Zukunft. Ein Projekt zum Gedächtnis an die Mariahilfer Opfer des NS-Terrors*, Vienna: Echomedia 2009, pp. 147–150, here p. 148 [our trans.].

61 See “Kino-Programme,” in: *Die Stunde* (Vienna), May 13, 1933, p. 4.

62 Cit. after Rolf Aurich, Wolfgang Jacobson, Cornelius Schnauber (eds.): *Fritz Lang. Leben und Werk. Bilder und Dokumente*, Berlin: jovis 2001, p. 194 [our trans.]. On the evening of the same day that he viewed *The Testament of Dr. Mabuse*, March 28, 1933, Goebbels gave a speech →

thus held in Budapest on April 21 and the Austrian premiere in Vienna on May 12.

The testament of the title refers to written notes intended as a guide to major crimes. Locked up in his cell, Dr. Mabuse (Rudolf Klein-Rogge) fills page after page with detailed instructions, which his obsessed physician Professor Baum (Oscar Beregi), the director of the mental hospital, puts into practice. As the head of a criminal organization, he passes on Mabuse's commands by telephone to employees who never see his face. The orders are explained in a kind of **control center**—a windowless room with a curtain, behind which a **figure is visible** and a voice audible. In fact, however, the gang's leader is not in the room, but only a dummy and a table with a **microphone and loudspeaker**. To conceal his absences from the clinic, Baum installs another media apparatus. He links a gramophone to the door handle using a wire, so that every attempt to enter his office triggers a recording saying: "I do not want to be disturbed now."⁶³

III.2.4

Fig. 94, p. 224

Fig. 96, p. 224

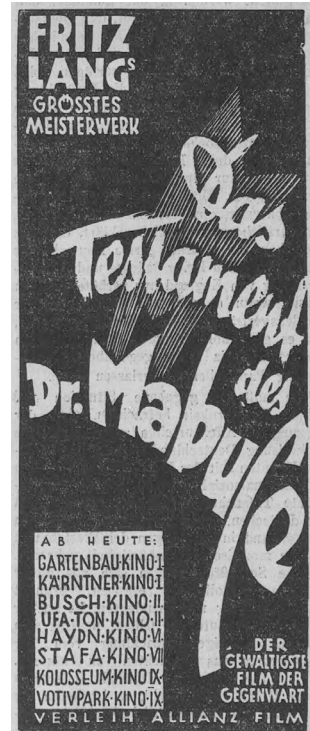

Fig. 23: Advertisement for the screening of Fritz Lang's film *The Testament of Dr. Mabuse* in eight movie theaters in Vienna on May 13, 1933, printed in *Die Stunde* (Vienna), May 13, 1933, p. 1. Source: Austrian National Library, 606233-D.

"The dramatic conflict that appears to fascinate Fritz Lang time and again is the collision between the criminal imagination of inventive delinquents and the objective researcher's

→ in front of German filmmakers at the Berlin Kaiserhof hotel, in which he singled out the movie *Die Nibelungen* (1924) by Fritz Lang as an exemplary artwork (see *ibid.*, pp. 215–216).

63 Cit. after Fritz Lang: *Das Testament des Dr. Mabuse*, 35 mm film, Berlin: Nero Film AG 1933 [our trans.], source: Film Archive of the Federal Archives (Berlin), BSP 26989-12.

logic of the detective,” the film critic Fritz Rosenfeld writes in the Vienna *Arbeiter-Zeitung* from Sunday, May 14, 1933.⁶⁴ In *The Testament of Dr. Mabuse*, this conflict intensifies on the basis of characters featured in Lang’s earlier works: the criminal psychologist from *Dr. Mabuse the Gambler* (1922) and the analytical inspector from *M* (1931). The psychopath Mabuse is insane and at the same time a genius; he writes logical plans for crimes with the sole purpose of causing chaos. Lohmann (Otto Wernicke), the police officer, on the other hand, attempts to create order by using his criminalistic intelligence, in other words establishing facts, analyzing photos, interrogating witnesses, etc. In both cases, imagination is at play—as the inspector’s controlled mental faculty and the psychopath’s unbridled fantasies.

Fig. 101, p. 234

The **UFA Ton Kino** was opened in 1916 as the Central Kino. Located on the ground floor of Hotel Central at Taborstrasse 8, it was not renamed until 1929 although the eponymous German Universum Film AG (UFA) had long held shares in the Vienna company.⁶⁵ The movie theater had a capacity of around one thousand seats and was used for premieres of UFA productions. On the evening of May 13, 1933, the UFA Ton Kino shows the *Ufa-Tonwoche* newsreel before *The Testament of Dr. Mabuse*, reporting on the Nazi celebration for the “Day of National Work” in Berlin on May 1.⁶⁶

64 Fritz Rosenfeld: “Die Herrschaft des Verbrechens,” in: *Arbeiter-Zeitung* (Vienna), May 14, 1933, p. 17 [our trans.].

65 See Werner Michael Schwarz: *Kino und Kinos in Wien. Eine Entwicklungsgeschichte bis 1934*, Vienna: Turia + Kant 1992, p. 176.

66 See “Lichtspiele,” in: *Deutschösterreichische Tages-Zeitung* (Vienna), May 13, 1933, p. 14.



6. Burgtheater

place Ring des 12. November 2, I Innere Stadt 67
time May 13, 1933, 7:30 p.m. to 10:30 p.m.

While Fritz Lang's *The Testament of Dr. Mabuse* is showing at the UFA Ton Kino and adherents of National Socialism are holding a "Turks Deliverance Celebration" (*Türkenbefreiungsfeier*) in the Engelmann Arena, the Vienna Burgtheater stages the play *Hundert Tage* (*Hundred Days*) on Saturday evening, May 13, 1933, starting at 7:30 p.m.⁶⁷ Its original Italian version, under the title of *Campo di maggio*, was written by Giovacchino Forzano based on instructions from Italian Prime Minister Benito Mussolini and translated into German by Géza Herczeg. Following the world premiere in Rome on December 30, 1930, the Burgtheater production opened on April 22, 1933, with

Fig. 24, p. 65



Fig. 24: Review of the premiere of the play *Hundred Days* (*Campo di maggio*), written by Giovacchino Forzano and Benito Mussolini, at the Burgtheater in Vienna on April 22, 1933, published in *Das interessante Blatt* (Vienna), 52/17 (April 27, 1933), p. 16. In the photos: among others, Werner Kraus as Napoleon (on the left and top right) and Fred Hennings as Joseph Fouché (bottom right). Source: Austrian National Library, 399792-D.

67 Today Universitätsring 2.
68 See "Theater," in: *Neue Freie Presse* (Vienna), May 13, 1933 (morning edition), p. 16.

Werner Krauss as Napoleon. The third act was broadcast internationally on the radio.⁶⁹

The drama deals with Napoleon's hundred-day rule in 1815, between his exiles on the islands of Elba and Saint Helena. Concerning the original title, the German edition published 1933 by Zsolnay in Vienna notes:

*“Campo di Maggio” (Campus Madius), Mayfield, was originally called “Campus Martius” (Champ de Mars) and was a popular assembly, military parade, war congress held once a year in March by the Merovingians. Pepin the Short postponed it to May. Charlemagne also held the “Mayfield” in June or August, just as the Napoleonic “Mayfield” likewise took place in the month of June.*⁷⁰

Fig. 64, p. 158

The play begins in the night before this national assembly on the Champ de Mars in Paris, **where Napoleon approves a constitution**. A grave mistake, as the later plot implies, for when the constitutional monarch returns from his defeat at Waterloo the parliament denies him its support to defend his fatherland. Napoleon is forced to flee and France must accept a humiliating peace. Almost all reviews of the performance at the Burgtheater published in the Vienna press emphasized Mussolini's message as being that Napoleon did not fail as a statesman because of his military defeat, but because he had become entangled with democracy. “One man, one only, but this right man in the right place,” the theater critic of the Christian Social *Reichspost* summarized the drama's lesson, “can bring salvation at the most dangerous of moments.”⁷¹

III.1.2

With regard to the play's political tendency, David Josef Bach criticized in the Social Democratic *Arbeiter-Zeitung* that the Vienna production undertook “alterations, exaggerations,

69 See “Radio-Wochenprogramm vom 22. bis 30. April,” in: *Neue Freie Presse* (Vienna), April 22, 1933 (evening edition), p. 4.

70 Benito Mussolini and Giovacchino Forzano: *Hundert Tage (Campo di maggio). Drei Akte in neun Bildern. Autorisierte Übersetzung von Géza Herczeg*, Vienna: Zsolnay 1933 [Italian 1931], p. 8 [our trans].

71 Hans Brecka: “Hundert Tage,” in: *Reichspost* (Vienna), April 23, 1933, pp. 2–3, here p. 3 [our trans.]. For an overview of contemporary reviews of the Vienna production of *Hundred Days*, see Robert Pyrah: *The Burgtheater and Austrian Identity. Theatre and Cultural Politics in Vienna, 1918–38*, London: Legenda 2007, pp. 188–190.

falsifications” of the published script.⁷² The stage version by the Austrian journalist and playwright Hanns Süssmann, which Burgtheater Manager Hermann Röbbling directed himself, did in fact differ from Herczeg’s translation. For instance, the key scene, in which Napoleon speaks before the Paris council of ministers after the Battle of Waterloo, reads as follows in the published German edition:

*Gentlemen! I have returned to encourage the nation to soar to a noble sacrifice, so that France may rise again and the enemy be destroyed. All is lost if we lose time now on speeches instead of taking action. The enemy is encamped in France. Extraordinary measures are necessary. I require special authority in order to save the fatherland. I demand dictatorship for a specified period. For the sake of the people, I could easily take possession of it. Yet in the interest of the nation’s prestige, I consider it more dignified and, in the face of the enemy, cleverer if the dictatorship is offered to me by the chamber.*⁷³

Alongside minor changes, the passage in the Burgtheater promptbook contains the following additional sentence: “I could abolish the constitution, for a constitution disproves itself if it disrupts the actions of those governing.”⁷⁴ This standpoint echoed the argumentation of Austrian Federal Chancellor Engelbert Dollfuß, who had been ruling the country by emergency decree since March 1933. With the support of Mussolini, himself the *Duce del fascismo* in Italy, the Christian Social politician wanted to reshape the democratic republic into an authoritarian “corporative state” (*Ständestaat*) under his command. Like Napoleon in *Hundred Days*, the Austrian government emphasized that their special rights were necessary to defend the sovereignty of the fatherland. In the play,

III.1.4 &
Fig. 65, p. 161

72 David Josef Bach: “Das Ende einer Diktatur,” in: *Arbeiter-Zeitung* (Vienna), April 23, 1933, p. 7 [our trans.].

73 Mussolini and Forzano: *Hundert Tage*, p. 91 [our trans.].

74 Promptbook *Hundert Tage*, Vienna: Georg Marton 1933, p. 53 [our trans.], source: Archive of the Burgtheater in Vienna, 609 R. See also Margret Dietrich: “Burgtheaterpublikum und Öffentlichkeit in der Ersten Republik,” in: Margret Dietrich (ed.): *Das Burgtheater und sein Publikum*, vol. I, Vienna: Österreichische Akademie der Wissenschaften 1976, pp. 479–707, here pp. 687–688.

Minister of Police Joseph Fouché embodies the type of the unscrupulous official, supposed to work for the country but only pursuing his own interests. His antithesis is Napoleon as a sensible leader, acting in the people's best interests—a role that Dollfuss imagined for himself.

Hundred Days was an exceptional success with Viennese audiences. “The Caesarean efforts of all those involved were greeted by truly Napoleonic applause,” wrote the theater critic

II.9 Raoul Auernheimer in the bourgeois *Neue Freie Presse* after the premiere.⁷⁵ Up to the end of June 1933, the play was staged a further thirty-five times and seen by some 54,000 theatergoers.⁷⁶ Declared a German National Theater by Emperor Joseph II in 1776, the **Burgtheater** has been located opposite Vienna City Hall on the Ringstrasse since 1888.

Fig. 59, p. 152

7. Engelmann Arena



place Jörgerstrasse 24, XVII Hernalss
time May 13, 1933, 8:30 p.m. to 10:00 p.m.

A National Socialist “Turks Deliverance Celebration” (*Türkenbefreiungsfeier*) takes place in the Vienna Engelmann Arena at Jörgerstrasse 24—an ice rink that was also used for political rallies—from 8:30 to 10:00 p.m. on Saturday, May 13, 1933.

The speeches are relayed via loudspeaker in the neighboring restaurant Stalehner.⁷⁷ The German Nazi politicians, having

II.1 landed at **Aspern airfield** that afternoon and proceeded to the
II.4 **Adolf Hitler House** in a motorcade, march to the grandstand to the sound of the “Prinz Eugene March.”⁷⁸

75 Raoul Auernheimer: “Mussolinis Napoleon,” in: *Neue Freie Presse* (Vienna), April 23, 1933 (morning edition), pp. 1–3, here p. 3 [our trans.].

76 See Dietrich: “Burgtheaterpublikum und Öffentlichkeit in der Ersten Republik,” pp. 684 and 692.

77 See “Lärmender Empfang der nationalsozialistischen Minister,” in: *Neue Freie Presse* (Vienna), May 14, 1933 (morning edition), p. 7.

78 See a report by the Federal Police Headquarters in Vienna from May 14, 1933, in the Austrian State Archives (ÖStA/AdR, BKA-I, 148.459/33).

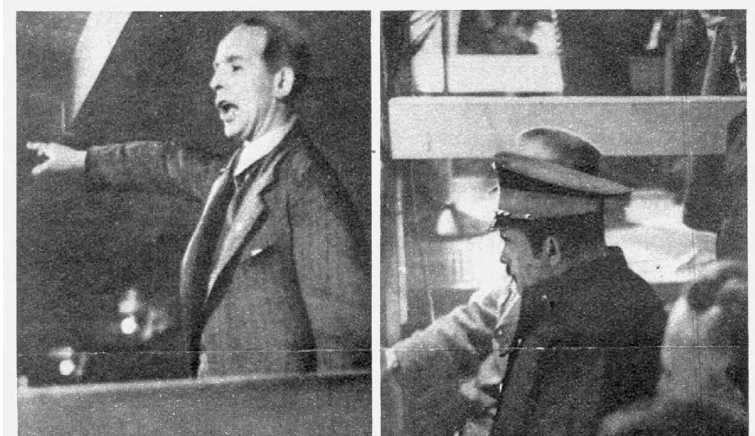

Fig. 25: Roland Freisler (on the left) holding a speech at the National Socialist “Turks Deliverance Celebration” in the Engelmann Arena in Vienna on the evening of May 13, 1933. The picture on the right shows a police officer sent by the Austrian government to monitor the event. These photos were published in *Das interessante Blatt* (Vienna), 52/20 (May 18, 1933), p. 4. Source: Austrian National Library, 399792-D.

Fig. 25, p. 69

Whereas the Nazi press reports 20,000 participants, a **police officer on duty** estimates the audience at 11,000.⁷⁹ The officer was sent by the Austrian federal government to monitor the event. The NSDAP has permission solely for a commemoration of the 250th anniversary of Vienna’s liberation from the second Ottoman siege, which actually happened not in May, but in mid-September 1683. Comments on the current political situation, however, are officially prohibited. The first to speak is the Nazi gau administrator (*Gauleiter*) of Vienna, Alfred Eduard Frauenfeld:

*I believe I express the sentiments of us all when I say that we will prove ourselves worthy to our ancestors. Just as they drove out the enemy from the gates of Vienna and won the German people its freedom, so we shall do the same and liberate Vienna from the representatives of Asia, no matter whether they wear a fez or a rooster’s tail.*⁸⁰

79 See *ibid.* vs. “Überwältigende Feier in der Engelmann-Arena,” in: *Deutschösterreichische Tages-Zeitung* (Vienna), May 14, 1933, p. 2.

80 Cit. after “Überwältigende Feier in der Engelmann-Arena” [our trans.].

III.2.1 &
Fig. 75, p. 189

II.10

III.1.5

II.9

The “rooster’s tail” (*Hahnenschwanz*) is an allusion to the decorated hats worn by the Austrian **Home Guards** (*Heimwehren*)—a paramilitary organization holding its own “Turks Deliverance Celebration” the following morning in the **gardens of Schönbrunn Palace**. After Bavarian Minister of Justice Hans Frank praises Adolf Hitler as a new “deliverer from the Turks,” his Prussian counterpart Hanns Kerrl purports an emotional connection between the “national comrades” in Germany and Austria: “God bound us together through our blood and blood is the true determiner of man’s actions and wishes.”⁸¹ At the end of the rally, the speakers and their listeners, accompanied by a Vienna SA band, sing the *Deutschlandlied* and the *Horst-Wessel-Lied*, the NSDAP’s party anthem.

In its editorial in the morning edition of May 13, the bourgeois *Neue Freie Presse* had expected parallels to be sought between 1683 and 1933 at the evening event in the Engelmann Arena. There was, however, apparently “not a trace of analogy” between the second Ottoman siege of Vienna and the current battles in the name of National Socialism:

*For the throng that descended the Kahlenberg to drive the Janissaries out of the territories of Western culture at Sievering and Döbling were not only Germans and Austrians, there were also Poles under King Sobieski; it was a motley army without the slightest wish for “Gleichschaltung” [coordination]. The sad thing is that the eye for historical correctness has disappeared to such an extent. That a watchword is to be used, merely one insignia more in this age of appearances.*⁸²

81 Cit. after “Die nationalsozialistische Türkenbefreiungsfeier in der Engelmann-Arena,” in: *Deutschösterreichische Tages-Zeitung* (Vienna), May 16, 1933, p. 4 [our trans].

82 “Ruhiger Verlauf des Tages zu erwarten,” in: *Neue Freie Presse* (Vienna), May 13, 1933 (morning edition), pp. 1–2, here p. 2 [our trans.].

8. Friedensbrücken Kino



place Klosterneuburger Strasse 33, XX Brigittenau
 time May 13, 1933, 11:00 p.m. to 1:00 a.m.

Fig. 26, p. 73

On Saturday night, May 13, 1933, **two exemplary works of Russian film** are screened in the Vienna Friedensbrücken Kino at Klosterneuburger Strasse 33: starting at 11 p.m., the Association of Friends of the Soviet Union (*Bund der Freunde der Sowjetunion*) shows Sergei Eisenstein's *Panzerkreuzer Potemkin* (*Battleship Potemkin*) and Viktor Turin's *Turksib*.⁸³ Founded in 1928, the association was a group of communists led by the doctor and writer Marie Frischauf, with the aim of propagating the USSR's policies in Austria. It published a journal, held lectures and exhibitions, and in 1931 organized an excursion to the "workers' paradise" in the East.⁸⁴ One of the group's main advertising media was Russian films, which were screened in various small movie theaters. Opened in 1913 as Wailand Lichtspieltheater, the Friedensbrücken Kino had seats for 360 viewers around 1930.⁸⁵

Fig. 92, p. 219

The silent film *Battleship Potemkin*,⁸⁶ premiered in Moscow in 1925, tells the story of a mutiny that had taken place on the **Potemkin warship** in the revolutionary year 1905. The crew refuses to eat rotten meat, throws the czarist officers overboard, and joins forces with the striking citizens of the port town of Odessa, where the uprising is brutally suppressed by Cossacks. The Potemkin, however, evades the approaching squadron as the ships lower their guns to let the escaping comrades pass. In the film's most famous sequence, in which

83 See *Die Rote Fahne* (Vienna), May 13, 1933, p. 4.

84 See Peter Grabher: "Sowjet-Projektionen. Die Filmarbeit der kommunistischen Organisationen in der Ersten Republik (1918–1933)," in: Christian Dewald (ed.): *Arbeiterkino. Linke Filmkultur der Ersten Republik*, Vienna: Filmarchiv Austria 2007, pp. 221–303, here pp. 278–279 [our trans.].

85 See Werner Michael Schwarz: *Kino und Kinos in Wien. Eine Entwicklungsgeschichte bis 1934*, Vienna: Turia + Kant 1992, p. 289.

86 The German versions from 1926 and 1930, for which Edmund Meisel composed the music, are contained in the DVD *Panzerkreuzer Potemkin & Oktjabr'*, Munich: Edition Filmmuseum 2014.

the people of Odessa flee from the shooting soldiers on the harbor steps, close-ups of rows of stamping boots are intercut with pictures of a desperate mother holding her shot child in her arms, rifle barrels are contrasted with horrified faces in shorter and shorter cuts, as a baby in a buggy rolls down the steps. The scene is intended to create pathos, to put the audience into an ecstatic state.⁸⁷

III.2.3

According to Eisenstein's understanding, the physical, emotional, and intellectual effects of film merge. The **montage of camera shots** prompts motor movements: the spectator flinches, pulls a face, covers their eyes. The rising abhorrence and the conclusion that justice must be done are also, in Eisenstein's view, (brain-based) physiological reactions to sensory stimuli.⁸⁸ Whether the director succeeds in creating this effect is a question of artistic skill. In the case of *Battleship Potemkin*, professional opinion has always been undivided, even that of Joseph Goebbels: "It is wonderfully made, it signifies filmic art without parallel," the National Socialist propaganda minister said in a speech to German filmmakers in Berlin on May 28, 1933.⁸⁹

Turksib was also a major success around 1930, but in film scholarship it has not been regarded as a masterpiece.⁹⁰ Viktor Turin, who had studied in the USA, made the documentary about the Soviet construction project, the Turkestan-Siberian railway, in the style of a drama. He used a screenplay by Viktor Shklovsky, employed workers as actors, and outstretched the budget of the small Vostok Kino studio. When the film was released in 1929, critics and audiences were hugely

- 87 See Sergei Eisenstein: "Organic Unity and Pathos in the Composition of *Potemkin*" [Russian 1939], in: *Notes of a Film Director*, ed. R. Yurenev and G. Ivanov-Mumjiev, trans. X. Danko, Moscow: Foreign Languages Publishing House 1959, pp. 53–62, here pp. 59–60.
- 88 See Sergei Eisenstein: "The Fourth Dimension in Cinema" [Russian 1929], in: *Selected Works. Vol. 1: Writings, 1922–34*, ed. and trans. Richard Taylor, London: BFI 1988, pp. 181–194, here p. 193.
- 89 Joseph Goebbels: "Rede im Kaiserhof am 28.3.1933," in: Gerd Albrecht (ed.): *Der Film im Dritten Reich. Eine Dokumentation*, Karlsruhe: Doku Verlag 1979, pp. 26–31, here p. 27 [our trans.].
- 90 See Matthew J. Payne: "Viktor Turin's 'Turksib' (1929) and Soviet Orientalism," in: *Historical Journal of Film, Radio and Television*, 21/1 (2001), pp. 37–62, here p. 37.

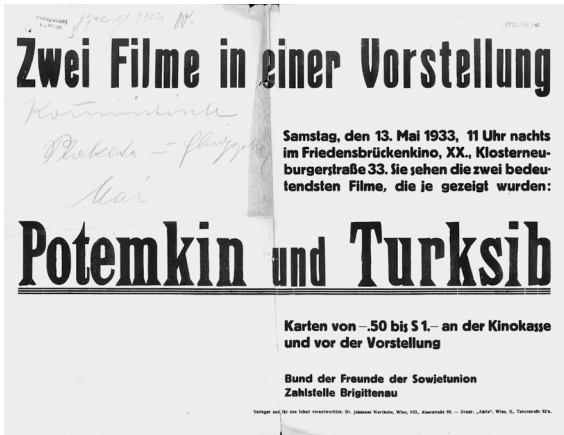

Fig. 26: Poster by the communist Association of Friends of the Soviet Union announcing the screening of Sergei Eisenstein's *Battleship Potemkin* and Viktor Turin's *Turksib* at the Friedensbrücken Kino in Vienna from 11 p.m. on May 13, 1933. Source: Austrian National Library, PLA16304668.

Fig. 93, p. 221

impressed—not only in Russia, but in the rest of Europe as well.⁹¹ *Turksib* presents the building of the railway line as a battle against nature by man and machines. Once the engineers have surveyed the land and planned the line, civilization in the form of the **steam-driven steel machine** breaks through deserts and ice to transport grain to the south and cotton to the north of the Soviet Union.⁹²

Turin's Orientalist view of the Asian parts of the state is clear in a sequence staging a race between nomads and a locomotive. Kazakh riders chase after the train on horses, bulls, and camels, but they seem ridiculous with their animals in contrast to the fast-moving engine, its iron wheels and pillars of smoke appearing huge on the screen. Hence, *Turksib* does not show a class conflict, but an ethnic gap between progressive Europeans and backward Asians—a message that may well have helped the film to its international success.⁹³ In Vienna on May 13 and 14, 1933, at least, this dichotomy was something the hostile parties could agree on, be it in a communist movie night or at the “Turks Deliverance Celebrations” (*Türkenbefreiungsfeiern*) held on Saturday in the **Engelmann Arena** and on Sunday in the **gardens of Schönbrunn Palace**.

II.7 · II.10

91 See Payne: “Viktor Turin’s ‘Turksib’ (1929) and Soviet Orientalism,” pp. 48–52.

92 The film’s English version, released by John Grierson in 1930, is contained in the DVD *The Soviet Influence. From Turksib to Night Mail*, London: BFI 2011.

93 See Payne: “Viktor Turin’s ‘Turksib’ (1929) and Soviet Orientalism,” pp. 53–56.

9. *Neue Freie Presse*



place Fichtegasse 11, I Innere Stadt
time May 14, 1933, 6:00 a.m.

Fig. 27, p. 75

Fig. 120, p. 280

In its Sunday edition on May 14, 1933, available from 6 a.m., the *Neue Freie Presse* publishes an essay under the title of “Humbug, Bluff, and Ballyhoo: From Barnum to Bernays.” The writer and theater director Arthur Rundt describes a historical “transformation of the American spirit” on the basis of **two experts on public opinion**: “At the beginning is the name of the great adman and showman Phineas Taylor Barnum, at the end that of the analyst of the mass psyche Eduard L. Bernays [...]”⁹⁴ Before the piece appeared in Vienna’s most important bourgeois newspaper, located at **Fichtegasse 11**, it had come out in the April issue of the Berlin journal *Der Querschnitt*.⁹⁵ It was based on an article on the “science of ballyhoo,” which John T. Flynn had published a year previously in *Atlantic Monthly*.⁹⁶ For both writers, Barnum’s great bluffs were a thing of the nineteenth century; contemporary America, however, was under the thrall of scientific public relations as practiced by Bernays, a nephew of Sigmund Freud.

Barnum’s career as a showman began in 1835, when he bought an old, blind slave and claimed she was Joice Heth, George Washington’s wet nurse. In actual fact, the woman was not 161 years old but only half that age, as was established after her death. “Humbug, bluff, and ballyhoo” was also staged for the American Museum in New York, which Barnum took over in 1841. The article in the *Neue Freie Presse* mentions, for instance, “General Tom Thumb”: Barnum taught a five-year-old little person to impersonate historical figures such as Hercules and Napoleon and presented the boy’s performances in his

- 94 Arthur Rundt: “Humbug, Bluff und Ballyhoo. Von Barnum bis Bernays,” in: *Neue Freie Presse* (Vienna), May 14, 1933 (morning edition), pp. 25–26 [our trans.]. The following short references relate to this source.
- 95 See Arthur Rundt: “Humbug, Bluff und Ballyhoo. Von Barnum bis Bernays,” in: *Der Querschnitt* (Berlin), 13/4 (April 1933), pp. 265–269.
- 96 See John T. Flynn: “Edward L. Bernays. The Science of Ballyhoo,” in: *Atlantic Monthly* (Boston), 149/5 (May 1932), pp. 562–571.

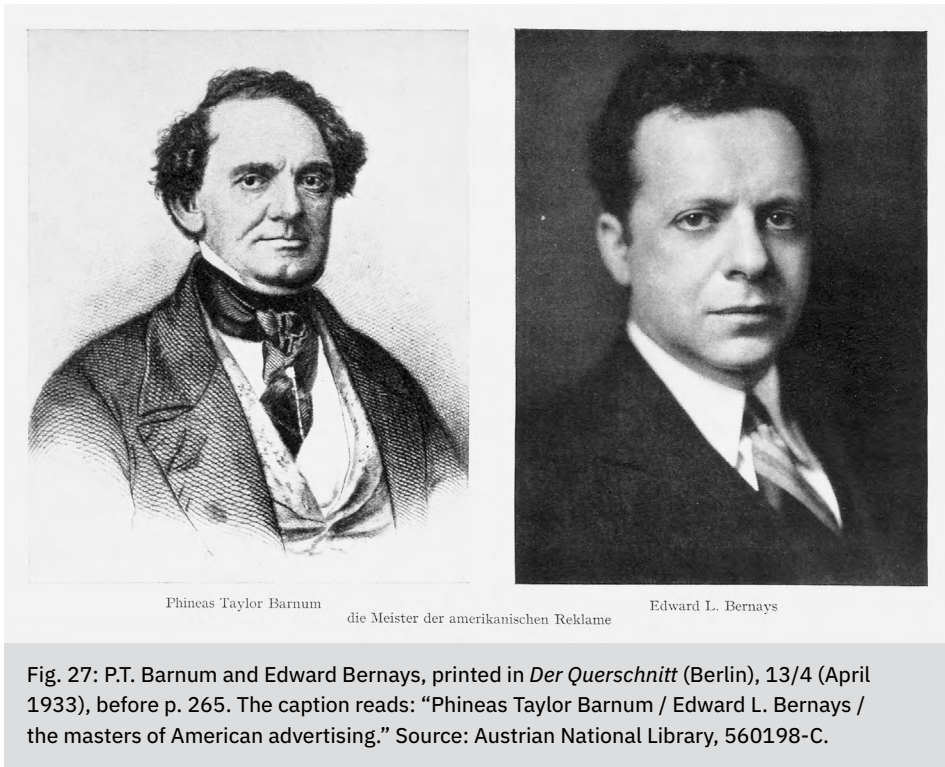

Fig. 27: P.T. Barnum and Edward Bernays, printed in *Der Querschnitt* (Berlin), 13/4 (April 1933), before p. 265. The caption reads: “Phineas Taylor Barnum / Edward L. Bernays / the masters of American advertising.” Source: Austrian National Library, 560198-C.

cabinet of curiosities.⁹⁷ As the show proved very successful, the two of them toured Europe, where General Thumb even performed before the queen of England and the Russian czar. After the American Museum burned down, Barnum founded a traveling circus. The main attraction, an African elephant, set off a wave of “Jumbomania” in the USA.⁹⁸

In contrast to Barnum, who called himself the “Prince of Humbugs,”⁹⁹ Edward Bernays preferred to manage his campaigns from the background. In the *Neue Freie Presse*, Rundt considered him the “most interesting and intellectually most serious representative” of ballyhoo, in other words of indirect

97 See Rundt: “Humbug, Bluff und Ballyhoo,” pp. 25–26.

98 See Susan Nance: “Elephants and the American Circus,” in: Susan Weber, Kenneth L. Ames, Matthew Wittmann (eds.): *The American Circus*, New Haven/London: Yale University Press 2012, pp. 232–249, here pp. 238–239.

99 Phineas Taylor Barnum: *Barnum, the Yankee Showman and Prince of Humbugs. Written by himself*, London: Piper 1855.

“advertising with a diversion via psychology.”¹⁰⁰ Edward had been born in Vienna in 1891 as the son of Sigmund Freud’s sister Anna and her husband Ely Bernays, the brother of Martha Bernays, Freud’s wife. The family emigrated a year later to the USA, where Bernays studied agriculture according to his father’s wishes but then jobbed as a journalist. During World War I, he worked for the Committee on Public Information, set up by President Woodrow Wilson as an American propaganda bureau.¹⁰¹

III.3.3 In 1919, Bernays opened his first agency in New York as a “**public relations counsel**”—a term occasionally used by the well-known publicist Ivy Lee.¹⁰² Unlike his predecessors, the young PR man did not try to promote his clients’ opinions and products by direct means, however, but aimed to establish circumstances that carved a trail for them. “Modern propaganda,” Bernays wrote in his programmatic book from 1928, “is a consistent, enduring effort to create or shape events to influence the relations of the public to an enterprise, idea or group.”¹⁰³

10. Schönbrunn Palace Gardens



place Schönbrunner Schlosstrasse, XIII Hietzing
time May 14, 1933, 9:00 a.m. to 12:00 p.m.

III.2.1 &
Fig. 28, p. 79

The Austrian Homeland Protection (*Heimatschutz*) holds a “Turks Deliverance Celebration” (*Türkenbefreiungsfeier*) in the gardens of Schönbrunn Palace on May 14, 1933. Members of the paramilitary **Home Guards** (*Heimwehren*) arrive on chartered trains from all over the country, setting out in the early morning from the stations to the former imperial residence and grouping in the Baroque gardens by 9 a.m. Depending on the political standpoint of the source, the participant numbers

- 100 Rundt: “Humbug, Bluff und Ballyhoo,” p. 25 [our trans.].
101 See Larry Tye: *The Father of Spin. Edward L. Bernays and the Birth of Public Relations*, New York: Crown 1998, pp. 18–19 and 115–120.
102 See Tye: *The Father of Spin*, p. 260.
103 Edward L. Bernays: *Propaganda*, New York: Horace Liveright 1928, p. 25.

II.13 & III.3.1 vary between 20,000 and 40,000.¹⁰⁴ Once the members of the federal government arrive, a Catholic Mass is read in the open air. The speeches commemorating the liberation from the second Ottoman siege of Vienna in 1683 begin at 10:20 a.m. and are broadcast live on *Radio Wien* until 11:05 a.m.¹⁰⁵ Following an aerial parade of Home Guard planes, the troops march via the Schlossallee, Mariahilfer Strasse, Babenbergerstrasse, and Ringstrasse to **Schwarzenbergplatz**, where the first men arrive at around 1 p.m.

III.1.1 The idea for the rally originated from the federal leader of the Austrian Homeland Protection, **Ernst Rüdiger Starhemberg**, who suggested holding a military review for propaganda purposes to Federal Chancellor Engelbert Dollfuss and secured financial support from **Benito Mussolini**, Italy's Fascist prime minister.¹⁰⁶ After Adolf Hitler had taken over as German chancellor at the end of January 1933, the Austrian government used the resignation of the presidents of the National Council in early March to adopt an authoritarian course of its own. The cabinet prevented parliament from working and governed by emergency decree. Although the 250th anniversary of Vienna's relief from the second Ottoman siege was not until September 12, the aim was to give a public signal of Austria as a sovereign German nation earlier in the year:

*The Turks Deliverance Celebration of the Austrian Homeland Protection has the purpose of reminding the comrades, but also other broad sections of the population, of the world-historical fact that Christianity, German customs and culture, and thus also the then German Reich were rescued from Eastern barbarism 250 years ago on Austrian soil.*¹⁰⁷

104 See, for example, "Der Spiessrutenlauf von Starhembergs Völkerbund," in: *Deutschösterreichische Tages-Zeitung* (Vienna), May 15, 1933, p. 1, vs. "Der Zug der Vierzigtausend durch Wien," in: *Reichspost* (Vienna), May 15, 1933, p. 1.

105 See "Radio-Wochenprogramm vom 13. bis 21. Mai," in: *Neue Freie Presse* (Vienna), May 13, 1933 (evening edition), p. 4.

106 See Ernst Rüdiger Starhemberg: *Between Hitler and Mussolini*, New York/London: Harper & Brothers 1942, pp. 95–117.

107 Ernst Rüdiger Starhemberg: "Schlusswort," in: Arthur Karg-Bebenburger: *Weisungen für die Türkenbefreiungs-Gedenkfeier am 14. Mai 1933* →

III.1.3

For this purpose, the federal government not only gave permission to use the former **Habsburg summer residence** as the event venue, the Schönbrunn Palace gardens built mainly in the eighteenth century, but granted exceptions to the current ban on parades on May 12, 1933. For “particular patriotic events promoting the state,” the official communication stated, Security Minister Emil Fey, who was also the leader of the Vienna Home Guard, could permit political rallies in consultation with the chancellor.¹⁰⁸

All three politicians—Fey, Starhemberg, and Dollfuss—appear as speakers at the “Turks Deliverance Celebration.” In his address, Fey recalls the genealogical line leading from the events of 1683 to Austria’s current situation.¹⁰⁹ He refers to Count Ernst Rüdiger von Starhemberg, the city commandant who had defended Vienna against the Ottoman troops and whose descendant of the same name now hoped to play a significant role in the construction of the authoritarian “corporative state” (*Ständestaat*). Starhemberg then addresses an appeal to Engelbert Dollfuss to put an end to the country’s “dishonorable existence” and to protect the people from “party politics” and “class warfare”: “Be that savior and be confident that everything supports you and everything is with you when you set about saving Austria.”¹¹⁰

The federal chancellor, wearing the uniform of the Tyrolean Imperial Infantry (*Tiroler Kaiserschützen*), maintains that the government had achieved more in two months than the “parliamentary machinery” in the previous two years. He was not fighting people, he claims, but “false ideas,” for after the end of the World War “the enemy has infiltrated the nation. Foreign spirit and foreign ideas,” Dollfuss says, “have infected our people, and wreaked evil havoc.” The aim, he states, is to “eradicate the red flood [...] in its innermost ideas” and also

→ *in Wien*, Vienna: Österreichischer Heimatschutzverband 1933, pp. 14–15, here p. 14 [our trans.].

108 Cit. after “Ausnahmen vom Aufmarschverbot statthaft,” in: *Reichspost* (Vienna), May 14, 1933, p. 1 [our trans.].

109 See “Die Türkenbefreiungsfeier in Schönbrunn,” in: *Reichspost* (Vienna), May 15, 1933, pp. 1–2, here p. 2.

110 Cit. after “Wir Heimatschützer decken den Bundeskanzler!,” in: *Reichspost* (Vienna), May 15, 1933, p. 2 [our trans.].

to stand proudly against the National Socialist agitation: “We intend to renew the spirit in our homeland under the symbol under which the Christian Occident was liberated from the Asians 250 years ago, under the symbol of the simple Christian cross.”¹¹¹

II.9 The bourgeois newspapers also emphasized the idea that it was European culture that was defended in the summer of 1683. For the *Neue Freie Presse*, the Ottoman siege was a “world decision between Western and Eastern mankind,” which had chosen Vienna as its arena.¹¹² In the magazine *Das interessante Blatt*, the then director of the Austrian State Archives, Heinrich Kretschmayr, described how the city had proven itself as a “barbican of Christendom.” With the battle of liberation of September 12, 1683, the Habsburg Monarchy had become a “performer of an achievement restricted by neither state nor nation, a pan-European achievement.”¹¹³ At the “Turks Deliverance Celebration” of May 14, 1933, in contrast, the historical idea that the Occident was saved in



Fig. 28: Poster announcing the “Turks Deliverance Celebration” held by the Austrian Homeland Protection in the gardens of Schönbrunn Palace in Vienna on May 14, 1933. In the foreground a prototypical Home Guard man is depicted, in the background Count Ernst Rüdiger von Starhemberg in front of Vienna’s St. Stephen’s Cathedral. Source: Austrian National Library, PLA16304635.

- 111 Cit. after “Die Rede des Bundeskanzlers,” in: *Reichspost* (Vienna), May 15, 1933, pp. 2–3, here p. 2 [our trans.].
- 112 “Die Befreiung Wiens und die Gegenwart,” in: *Neue Freie Presse* (Vienna), May 14, 1933 (morning edition), pp. 1–2, here p. 1 [our trans.].
- 113 Heinrich Kretschmayr: “Die historische Bedeutung der Befreiung Wiens,” in: *Das interessante Blatt* (Vienna), 52/22 (June 1, 1933), pp. 4–5, here p. 5 [our trans.].

☰ 🔍
campus | medius

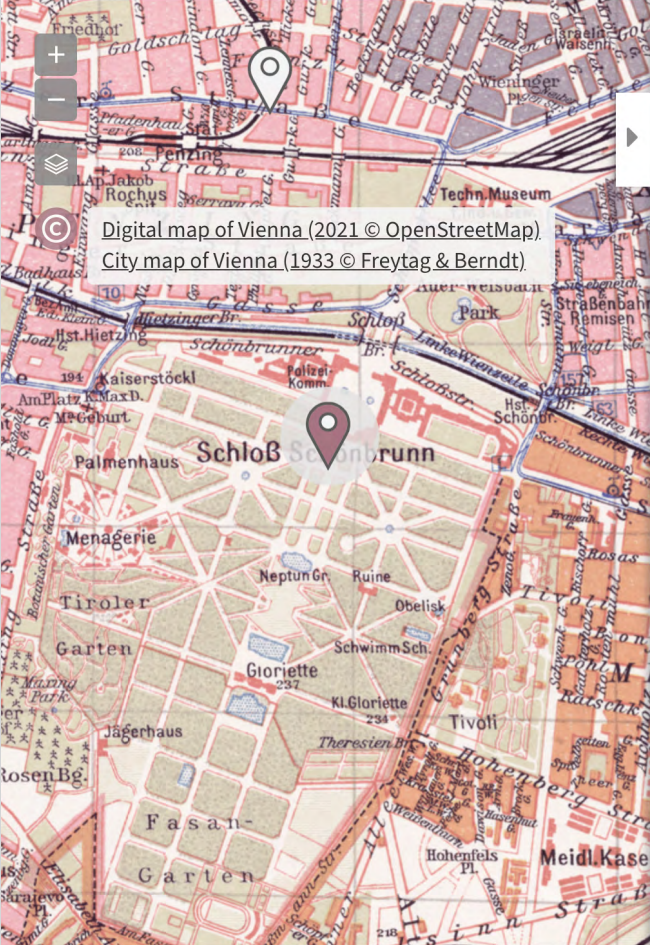

Digital map of Vienna (2021 © OpenStreetMap).
City map of Vienna (1933 © Freytag & Berndt)

99 Schönbrunn Palace Gardens

The Austrian Ho
Celebration" (Tü
1933. 📄 Membe
chartered trains
stations to the fo
9 a.m. 📄 Depen
numbers vary be

See, for example
*Deutschösterreic
Vierzigttausend d*

Once the membe
open air. The spe
sieger of Vienna i
until 11:05 a.m.
march via the Sc
Ringstrasse to Sc

timeline

16 h 24 h

May 13, 1933 – 2 p.m. May 14, 1933 – 2 p.m.



Fig. 29: Screenshot of the Topography module of the website campusmedius.net (desktop version 2.0/2021) showing the opened information of the event "Schönbrunn Palace Gardens"



Homeland Protection (*Heimatschutz*) holds a "Turks Deliverance" (*Völkerbefreiungsfeier*) in the gardens of Schönbrunn Palace on May 14, 1933. Members of the paramilitary Home Guards (*Heimwehren*) arrive on horseback from all over the country, setting out in the early morning from their homes in the former imperial residence and grouping in the Baroque gardens by the afternoon. Depending on the political standpoint of the source, the participant numbers range between 20,000 and 40,000.

See also: "Der Spiessrutenlauf von Starhembergs Völkerbund," in: *Österreichische Tages-Zeitung* (Vienna), May 15, 1933, p. 1, vs. "Der Zug der Heimwehren durch Wien," in: *Reichspost* (Vienna), May 15, 1933, p. 1.

After the members of the federal government arrive, a Catholic Mass is read in the Hofburg gardens commemorating the liberation from the second Ottoman siege of Vienna in 1683 begin at 10:20 a.m. and are broadcast live on Radio Wien. The speeches begin at 10:20 a.m. and are broadcast live on Radio Wien. Following an aerial parade of Home Guard planes, the troops march along the Ringstrasse, Schwarzenbergplatz, Mariahilfer Strasse, Babenbergerstrasse, and Schwarzenbergplatz, where the first men arrive at around 1 p.m.



and the timeline filtered from sixteen to twenty-four hours (text: Simon Ganahl, code: Andreas Krimbacher, design: Susanne Kiesenhofer).

Vienna served as motivation to maintain Austria as a sovereign nation. According to the *Neues Wiener Tagblatt*, in the gardens of Schönbrunn Palace “men true to the homeland” made an “avowal to the German-Austrian stock’s continuing will to live and to the resolution to continue the German mission in the southeast of the national settlement territory as an independent state, governing itself according to its own inherent laws.”¹¹⁴

Whether Austria ought to continue to exist as an independent state had been a controversial subject since the end of World War I. The position that the small remainder of the former Habsburg Monarchy ought to join the German Reich was taken not only by the right wing, but also by the Social Democrats, who changed their opinion after the National Socialist “seizure of power.” “Joining a free and peaceful Germany of the future remains our goal,” their central party newspaper prints on Saturday, May 13, 1933, “we fight all efforts for Austria joining the Fascist and nationalist Germany of today, as a threat to the freedom of the Austrian people and to peace in Europe.”¹¹⁵

II.7 While the National Socialists in the **Engelmann Arena** are calling for the two countries to merge, the Social Democratic Workers’ Party encourages its supporters to attend the republican **“freedom celebrations”** taking place on Sunday morning in Vienna’s municipal housing projects (*Gemeindebauten*)—the III.3.4 **Karl Marx Hof**, for instance. The Home Guard leaders, in contrast, turn their attention less to the future than to history, to II.12 a time “which we call the heroic age of Austria. A nation that does not honor its past has no future,” wrote Ernst Rüdiger Starhemberg in the closing remarks to the *Instructions for the Turks Deliverance Memorial Ceremony in Vienna on May 14, 1933*.¹¹⁶

114 “Der Heimwehraufmarsch in Wien,” in: *Neues Wiener Tagblatt* (Vienna), May 15, 1933, pp. 1–2, here p. 2 [our trans.].

115 “Weder Hitler noch Habsburg!,” in: *Arbeiter-Zeitung* (Vienna), May 13, 1933, pp. 1–2, here p. 1 [our trans.].

116 Starhemberg: “Schlusswort,” p. 14 [our trans.].

11. Tonkino Fischer



place Linzer Strasse 83, XIII Hietzing¹¹⁷
 time May 14, 1933, 9:00 a.m. to 12:00 p.m.

On Sunday morning, May 14, 1933, the propaganda film *Deutschland erwacht* (*Germany Awakes*) is screened at 9 and 11 a.m. in the Tonkino Fischer.¹¹⁸ Founded in 1914, the movie theater at Linzer Strasse 83 seated about 400 people.¹¹⁹ While the “Turks Deliverance Celebration” (*Türkenbefreiungsfeier*) of the Austrian Homeland Protection (*Heimatschutz*) is taking place in the nearby **gardens of Schönbrunn Palace**, adherents of National Socialism watch a so-called “document of the re-birth of Germany.” The almost one-hour sound film produced on behalf of the **NSDAP’s Reich Propaganda Headquarters** (*Reichspropagandaleitung*) passed the German film censorship board on April 19, 1933, and the Vienna film screening office in the following month.¹²⁰ *Germany Awakes* was intended as an official documentation of the Nazi “seizure of power.” The film includes footage of speeches and parades from Hitler’s appointment as Reich chancellor on January 30, 1933, up to the passing of the Enablement Act on March 23, 1933, which transferred legislative power from the Reichstag to the government. It ends with the flag of the German Empire dissolving to the National Socialist swastika.¹²¹

117 Today XIV Penzing.

118 See “Aus der nationalsozialistischen Freiheitsbewegung,” in: *Deutscherösterreichische Tages-Zeitung* (Vienna), May 13, 1933, p. 7.

119 See Werner Michael Schwarz: *Kino und Kinos in Wien. Eine Entwicklungsgeschichte bis 1934*, Vienna: Turia + Kant 1992, p. 259.

120 See Thomas Ballhausen and Paolo Caneppele (eds.): *Entscheidungen der Wiener Filmzensur. 1929–1933*, Vienna: Filmarchiv Austria 2003, p. 461.

121 *Deutschland erwacht*, 35 mm film, Berlin: NSDAP 1933, source: Film Archive of the Federal Archives (Berlin), K 125719-6.

” **Tonkino Fischer** ^

following month. + *Germany Awakes* was intended as an official documentation of the Nazi "seizure of power." The film includes footage of speeches and parades from Hitler's appointment as Reich chancellor on January 30, 1933, up to the passing of the Enablement Act on March 23, 1933, which transferred legislative power from the Reichstag to the government. It ends with the flag of the German Empire dissolving to the National Socialist swastika. x



Compilation of marching scenes from the film *Germany Awakes*, produced on behalf of the NSDAP's Reich Propaganda Headquarters in Berlin in 1933. Source: [Film Archive of the Federal Archives](#) (Berlin).

Fig. 30: Screenshot of the Topography module of the website campusmedius.net (mobile version 2.0/2021) showing the opened information of the event “Tonkino Fischer” (text: Simon Ganahl, code: Andreas Krimbacher, design: Susanne Kiesenhofer).

12. Karl Marx Hof



place Heiligenstädter Strasse 82–92, XIX Döbling
time May 14, 1933, 10:00 a.m. to 12:00 p.m.

II.10 · III.3.4

“The rooster tails are demonstrating for Fascism in Schönbrunn today,” prints the Social Democratic *Kleines Blatt* on Sunday, May 14, 1933. “The republican people of Vienna will celebrate republican freedom at the same hour in the municipal housing projects.”¹²² While the Austrian Homeland Protection (*Heimatschutz*) is evoking a bygone age of heroes in the **gardens of Schönbrunn Palace**, “Red Vienna” looks to a socialist future. On Saturday, May 13, 1933, the *Arbeiter-Zeitung* publishes a Social Democratic declaration strictly rejecting the annexation of Austria by a Germany under Adolf Hitler. However, “German-Austria” should not become an authoritarian “corporative state” (*Ständestaat*) as the federal government envisaged, but remain a democratic republic, offering asylum for “German freedom and German culture.” The long-term objective of the Austrian Social Democrats was still to “join a free and peaceful Germany of the future.”¹²³

Fig. 31, p. 87

One of the about fifty “**freedom celebrations**” taking place in Vienna on May 14, 1933, was organized in the Karl Marx Hof at Heiligenstädter Strasse 82–92, which continues to rank among the largest housing complexes in Vienna today. With 1,382 apartments for around 5,000 people, the municipal housing project (*Gemeindebau*) between the Heiligenstadt train station and the Hohe Warte stadium was the size of a small town. Open-air concerts and political speeches are held from 10 a.m. to 12 p.m. in the two courtyards linked by a **central tract** with driveways and tower constructions.¹²⁴ Only 28,751 of the 156,027 m² **ground area** were built on, just under a

Fig. 127, p. 297

Fig. 134, p. 302

122 “Wir kämpfen für die Freiheit,” in: *Das Kleine Blatt* (Vienna), May 14, 1933, p. 2 [our trans.]. The expression “rooster tails” (*Hahnenschwänzler*) is an allusion to the decorated hats worn by the Austrian Home Guards (*Heimwehren*).

123 “Weder Hitler noch Habsburg!,” in: *Arbeiter-Zeitung* (Vienna), May 13, 1933, pp. 1–2 [our trans.].

124 See “Die Freiheitsfeiern in den Wiener Bezirken,” in: *Arbeiter-Zeitung* (Vienna), May 15, 1933, p. 1.

fifth of the total area. The “freedom celebration” takes place among the spacious garden areas and playgrounds intended for community use.

Fig. 133, p. 300

“Only a municipal construction activity concerned with public health can and must consider the hygienic side of building in such extensive dimensions,” the Vienna municipal construction office declared in the brochure for the opening of the Karl Marx Hof.¹²⁵ The majority of the **apartments** were 38 to 48 m² and equipped with fitted kitchens, running water, and toilets. Communal facilities with baths and showers were built in the public part of the estate, along with electric laundrettes, two kindergartens, a dental clinic, a pharmacy and a health insurer with an outpatient clinic, a youth center, a post office, a public library, and numerous retail units.

It is characteristic of Vienna’s interwar urban planning that a single housing block rather than multiple smaller buildings was erected on the Hagenwiese in Heiligenstadt from 1926 to 1930. Instead of the Karl Marx Hof, a garden city would also have been a possibility, as the architect Adolf Loos had endorsed as head of the Vienna Settlement Office (*Siedlungsamt*) in the early 1920s.¹²⁶ The Social Democratic city government suggested another route, however, once the starvation after World War I was alleviated. From 1923 to 1934, around 400 municipal housing projects with approx. 64,000 apartments were constructed in Vienna, providing windows in all rooms, WCs, running water, and gas stoves.¹²⁷

The Karl Marx Hof is also typical in terms of design. Its architect Karl Ehn was a student of Otto Wagner, whose urban planning had a longstanding influence on the municipal housing program. The monumental residential blocks countered the bourgeois representative architecture of Vienna’s

125 *Der Karl Marx-Hof. Die Wohnhausanlage der Gemeinde Wien auf der Hagenwiese in Heiligenstadt*, ed. Wiener Stadtbauamt, Vienna: Thalia [1930], p. 5 [our trans.].

126 See Eve Blau: *The Architecture of Red Vienna 1919–1934*, Cambridge: MIT Press 1999, pp. 98–114.

127 See Eve Blau: “Wien 1919–1934. Grosstadt und Proletariat im ‘Roten Wien,’” in: Eve Blau and Monika Platzer (eds.): *Mythos Grosstadt. Architektur und Stadtbaukunst in Zentraleuropa 1890–1937*, Munich: Prestel 1999, pp. 205–214, here p. 206.



Fig. 31: Photographs of the “freedom celebrations” in Vienna’s municipal housing projects on May 14, 1933, printed in *Arbeiter-Zeitung* (Vienna), May 16, 1933, p. 3. Source: Austrian National Library, 974000-D.

Ringstrasse with socialist institutions. Life in public housing was organized according to strict rules—from schedules for garbage removal to gender segregation in the launderettes.¹²⁸ The communal solidarity for which the city government strived was to develop in the courtyards. Consequently, on May 14, 1933, the municipal housing projects served as infrastructure in which to build a counter-public against the Austrofascist “Turks Deliverance Celebration” (*Türkenbefreiungsfeier*).

13. *Radio Wien*



place Johannesgasse 4, I Innere Stadt
time May 14, 1933, 10:20 a.m. to 11:05 a.m.

From 10:20 to 11:05 a.m. on Sunday, May 14, 1933, *Radio Wien* broadcasts the speeches held at the “Turks Deliverance Celebration” (*Türkenbefreiungsfeier*) in the **gardens of Schönbrunn Palace**.¹²⁹ The speakers at the event, officially

- 128 See Gottfried Pirhofer and Reinhard Sieder: “Zur Konstitution der Arbeiterfamilie im Roten Wien. Familienpolitik, Kulturreform, Alltag und Ästhetik,” in: Michael Mitterauer and Reinhard Sieder (eds.): *Historische Familienforschung*, Frankfurt a.M.: Suhrkamp 1982, pp. 326–368.
- 129 See “Radio-Wochenprogramm vom 13. bis 21. Mai,” in: *Neue Freie Presse* (Vienna), May 13, 1933 (evening edition), p. 4.

III.1.1

commemorating Vienna's liberation from the second Ottoman siege in 1683, are the Home Guard (*Heimwehr*) leader **Ernst Rüdiger Starhemberg**, Security Minister Emil Fey, and Federal Chancellor Engelbert Dollfuss, who says into the row of microphones: "Foreign spirit and foreign ideas are in our people, have infected our people, and wreaked evil havoc."¹³⁰ To combat this enemy ideology—namely, "red" and "brown" socialism—the Austrian government, which has taken an authoritarian course since March 1933, uses radio for its propaganda purposes.¹³¹

III.3.1 &
Fig. 32, p. 89
III.3.5 &
Fig. 135, p. 307

The **live broadcast** of the rally in Schönbrunn breached a taboo and prompted public protest. The Social Democratic *Arbeiter-Zeitung* reported on May 16, 1933, that more than 10,000 listeners had **canceled their radio license**, because "on Sunday the so-called 'Turks Deliverance Celebration' by the Austrian Homeland Protection [*Heimatschutz*] was transmitted, departing from the practice up to now of not broadcasting party-political events on the radio."¹³² Since its foundation in 1924, the broadcasting company Radio Verkehrs AG (RAVAG) had been obliged to maintain political neutrality, which was monitored by an advisory board at weekly meetings.¹³³ The Federal Press Service within the Chancellery did exert an influence over news programs; however, there ought to be no party-political speeches on Austrian radio.

The opposition now criticized that the government was abusing *Radio Wien*, whose headquarters were located at Johannesgasse 4, as its mouthpiece. Speeches that were politically desirable were broadcast while opposing voices were silenced. As an example, the *Arbeiter-Zeitung* on the day of the "Turks

- 130 Cit. after the sound recording "Engelbert Dollfuss anlässlich einer Feier zur Erinnerung an die Befreiung Wiens von den Türken" (Vienna, May 14, 1933) [our trans.], CD, source: Österreichische Mediathek, 8-29501_b02.
- 131 See Wolfgang Duchkowitsch: "Umgang mit 'Schädlingen' und 'schädlichen Auswüchsen.' Zur Auslöschung der freien Medienstruktur im 'Ständestaat,'" in: Emmerich Tálos and Wolfgang Neugebauer (eds.): *Austrofaschismus. Politik – Ökonomie – Kultur. 1933–1938*, 5th ed., Vienna: LIT 2005, pp. 358–370, here pp. 366–368.
- 132 "Die Antwort auf den Kikeriki-Sonntag," in: *Arbeiter-Zeitung* (Vienna), May 16, 1933, p. 2 [our trans.].
- 133 See Viktor Ergert: *50 Jahre Rundfunk in Österreich. Vol. I: 1924–1945*, Vienna: Residenz 1974, pp. 45–46.



Fig. 32: Photographs of events from where the station *Radio Wien* reported live on May 14, 1933: the “Turks Deliverance Celebration” in the gardens of Schönbrunn Palace (at the top) and a relay race in the Prater park (at the bottom), printed in *Radio Wien* (Vienna), 9/34 (May 19, 1933), p. 2. Source: Austrian National Library, 607949-C.

Deliverance Celebration” cited a canceled program that had been scheduled for May 17, 1933. The Viennese District Councillor Kamilla Gross was to speak about the rights of domestic servants as part of the Chamber of Labor’s program. Her lecture was taken off the schedule with the justification that a social legislation reform was currently underway and there had been “complaints from housewives” about such broadcasts.¹³⁴

Fig. 117, p. 268

The gap between the radio program and the listeners’ wishes in Austria was also shown in a study carried out in the early 1930s by the **Wirtschaftspsychologische Forschungsstelle**. The RAVAG had commissioned this Center of Economic-Psychological Research, headed by Paul Lazarsfeld, to run a statistical audience survey. It produced a questionnaire, which was included in radio magazines in November 1931 and was also available in tobacco shops. The innovative aspect of the study, which presented its findings a year later, was not so much the quantitative measurement of listeners’ wishes, but rather the fact that it provided information on the likes and dislikes of various social groups.¹³⁵ The questionnaire included

134 “Das neueste Ravag-Stückl,” in: *Arbeiter-Zeitung* (Vienna), May 14, 1933, p. 3 [our trans.].

135 See Paul Lazarsfeld: “Hörerbefragung der Ravag,” in: Desmond Mark (ed.): *Paul Lazarsfelds Wiener RAVAG-Studie 1932. Der Beginn der modernen Rundfunkforschung*, Vienna: Guthmann-Peterson 1996, pp. 27–66.

- III.3.2 a section on age, gender, profession, and place of residence. By correlating radio programs with social data, the **RAVAG study** broke the mass audience down into specific target groups.

14. German Embassy



place Metternichgasse 3, III Landstrasse
time May 14, 1933, 1:00 p.m. to 2:00 p.m.

- II.10 While the Home Guard (*Heimwehr*) troops, after participating in the “Turks Deliverance Celebration” (*Türkenbefreiungsfeier*) in the **gardens of Schönbrunn Palace**, are parading on
II.15 **Schwarzenbergplatz**, a press conference is underway in the German embassy at Metternichgasse 3. At around 1 p.m. on Sunday, May 14, 1933, the National Socialist politicians from
II.1 Germany, who arrived at **Aspern airfield** the previous day, make official statements on their visit to Vienna for international journalists: “We love Austria,” says Bavarian Minister of Justice Hans Frank, “and no one will ever again wrest Austria from its affiliation with Germany.”¹³⁶

Hans Frank takes a car to Graz during the afternoon, where he holds a speech on the Schlossberg, “in which the Austrian federal government and the federal chancellor in particular were degraded and appeals were made to resist the federal government.”¹³⁷ His entourage, however, flies back to Berlin from Aspern that Sunday. When Frank attempts to make a public appearance in Salzburg the next day, May 15, 1933, the police prohibit him from giving any further speeches.¹³⁸ After the Nazi politician is expelled from Austria, diplomatic protests are lodged both in Vienna and Berlin.

- 136 Cit. after “Abreise der deutschen Funktionäre,” in: *Neue Freie Presse* (Vienna), May 15, 1933 (evening edition), p. 4 [our trans.].
137 “Ersuchen um Rückberufung Dr. Franks,” in: *Reichspost* (Vienna), May 16, 1933, p. 1 [our trans.].
138 See “Die Heimreise Dr. Franks,” in: *Neue Freie Presse* (Vienna), May 16, 1933 (evening edition), p. 2.

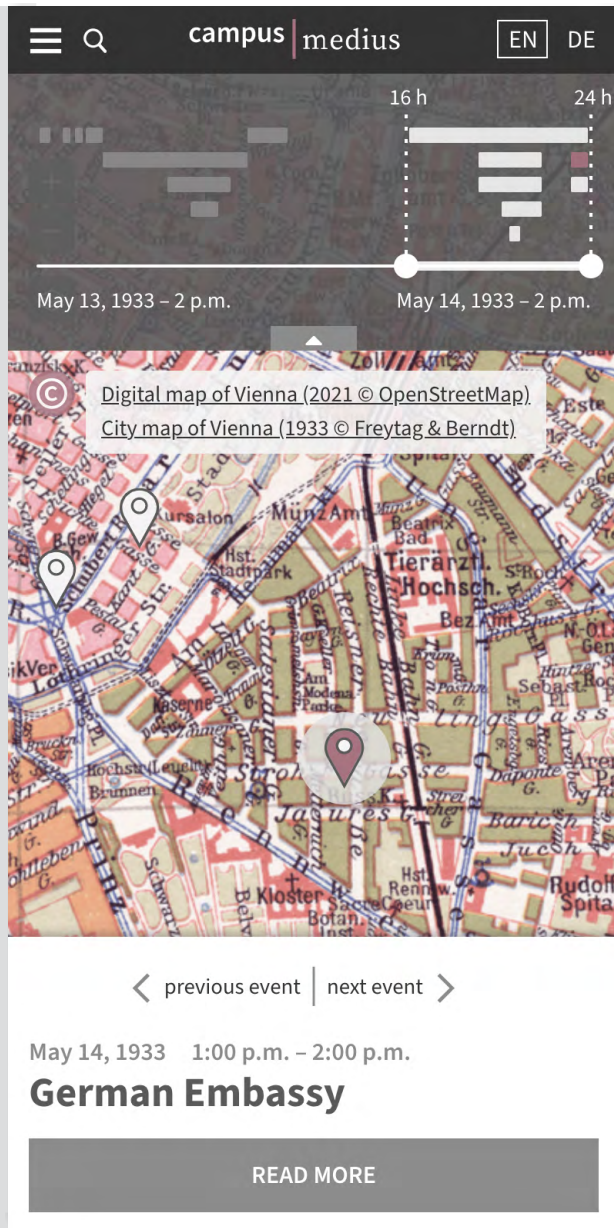

Fig. 33: Screenshot of the Topography module of the website campusmedius.net (mobile version 2.0/2021) showing the opened timeline, filtered from sixteen to twenty-four hours, and the selection of the event “German Embassy” (text: Simon Ganahl, code: Andreas Krimbacher, design: Susanne Kiesenhofer).

15. Schwarzenbergplatz



place Schwarzenbergplatz, I Innere Stadt
time May 14, 1933, 1:00 p.m. to 2:00 p.m.

- The Home Guard (*Heimwehr*) troops, who have taken part in the “Turks Deliverance Celebration” (*Türkenbefreiungsfeier*) in the
- II.10 **gardens of Schönbrunn Palace**, arrive at Schwarzenbergplatz from around 1 p.m. At the same time, the Nazi politicians from Germany, having landed some twenty-four hours previously at
- II.1 · II.14 **Aspern airfield**, hold a press conference in the **German embassy**. Government papers refer to 40,000, opposition papers to 20,000 men from all over Austria, marching via the Schlosstallee, Mariahilfer Strasse, Babenbergerstrasse, and Ringstrasse.¹³⁹ At the head of the parade are the Home Guard leaders **Ernst Rüdiger Starhemberg**, Emil Fey, and Richard Steidle, all with steel helmets and bull pizzles, followed by marching bands and the regional sections in traditional dress or uniform. On
- III.1.1 & Fig. 80, p. 197 **Schwarzenbergplatz**, government members headed by Federal Chancellor Engelbert Dollfuss review the procession.
- Fig. 34, p. 93 There is great public interest in this **march by the Austrian Homeland Protection** (*Heimatschutz*), which was permitted as a patriotic event despite the current ban on parades. Men raise their hats at the side of the road, women wave handkerchiefs. However, there are also attempts at disruption by political opponents: Social Democrats whistle and throw eggs, National Socialists shout “Heil Hitler!” and sing the
- III.2.1 & Fig. 74, p. 186 ***Deutschlandlied***.¹⁴⁰ Mounted police storm the demonstrators, using truncheons and bayonets. 530 people are arrested over the course of the day.¹⁴¹

139 See, for example, “Der Zug der Vierzigtausend durch Wien,” in: *Reichspost* (Vienna), May 15, 1933, p. 1, vs. “Der Spiessrutenlauf von Starhembergs Völkerbund,” in: *Deutschösterreichische Tages-Zeitung* (Vienna), May 15, 1933, p. 1.

140 See “Die Türkenbefreiungsfeier des österreichischen Heimatschutzes in Wien”, in: *Jahresschau 1933 der Bundespolizeidirektion in Wien. Eine Chronik im Laufbild*, 35 mm film, source: Filmarchiv Austria, JS 1933/8.

141 See “530 Personen festgenommen,” in: *Wiener Zeitung* (Vienna), May 16, 1933, p. 4.



Fig. 34: Austrian Home Guard men lower the flags on Schwarzenbergplatz in Vienna on the afternoon of May 14, 1933, as they march past representatives of the federal government and of the Homeland Protection, including Engelbert Dollfuss (second from left) and Ernst Rüdiger Starhemberg (third from left), who review and salute the paramilitary parade. Source: Austrian National Library, H 2012/1.

The *Arbeiter-Zeitung* asked itself in retrospect what was behind “all this enthusiasm from the bourgeois ‘democrats’ for the Sunday parade.” For the official newspaper of the Austrian Social Democrats, the answer was the “mindset of the Jewish bourgeois,” who could happily live with Fascism without antisemitism: “That is why he is against Hitler; he has nothing against Starhemberg.”¹⁴² According to the *Deutschösterreichische Tages-Zeitung*, the National Socialist party newspaper in Austria, “the three-hour march-past offered a ghastly picture,” which had left the impression of a defeated army.¹⁴³ *Die Stunde*, however, was pleasantly surprised: the Homeland Protection did not, as expected, represent a “traditional costume museum come to life,” but “one of the most vital sources of strength for the new Austrian spirit.” Whereas “excited youths” had cheered on the German National Socialists the previous day, the “older vintages” now mustered. “Sunday demonstrated against Saturday,” wrote the Vienna tabloid.¹⁴⁴

142 “Bürgerliche ‘Demokraten,’” in: *Arbeiter-Zeitung* (Vienna), May 16, 1933, p. 2 [our trans.].

143 “‘Innsbrucker Empfang’ der Starhemberg-Heimwehr in Wien,” in: *Deutschösterreichische Tages-Zeitung* (Vienna), May 15, 1933, p. 2 [our trans.].

144 “Der grosse Heimwehraufmarsch,” in: *Die Stunde* (Vienna), May 16, 1933, p. 2 [our trans.].

Topology:
The “Turks Deliverance
Celebration” in Vienna
on May 14, 1933,
imparted from
multiple perspectives
in three mediations by
five mediators each.

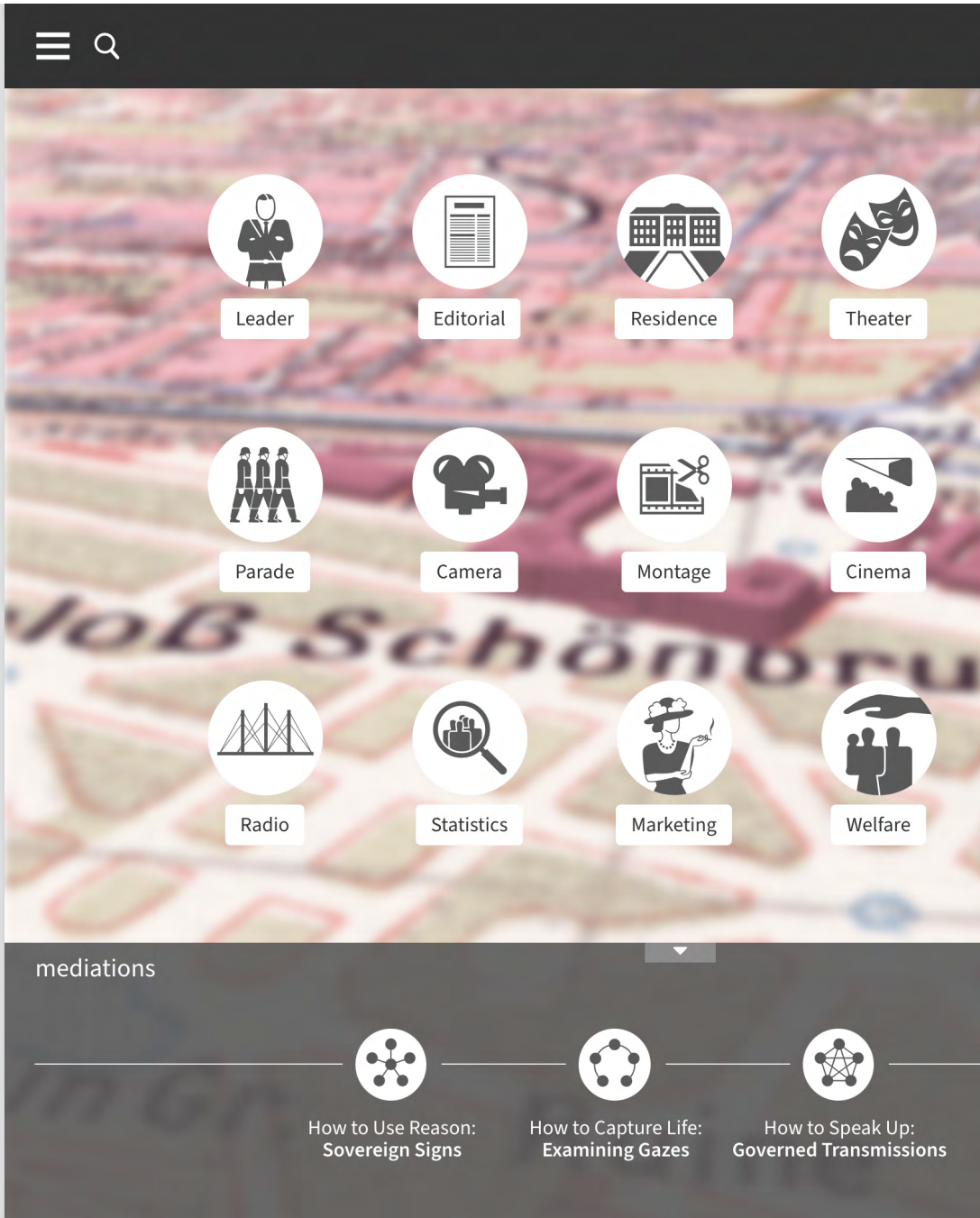

Fig. 35: Screenshot of the website campusmedius.net (desktop version 2.0/2021) showing the start page of the Topology module (text: Simon Ganahl, code: Andreas Krimbacher, design: Susanne Kiesenhofer).



Reframing



Exposure



Cancellation

Topology

The Topology of *Campus Medius* focuses on the main event of the exemplary time-space displayed in the [Topography](#) module with an interactive map and a timeline. This Austrofascist "Turks Deliverance Celebration" (*Türkenbefreiungsfeier*) in Vienna on May 14, 1933, is imparted here in three mediations by five mediators each.

[START](#)

The QR code leads
to the corresponding
web page.



How to Use Reason: Sovereign Signs

SPACE	LIMITED
TIME	INFINITE
VALUE	CENTRALIZED
PERSPECTIVE	BIRD'S-EYE
NAVIGATION	ZOOMING

GOD 1.0

In contrast to the other two mediations, which are implemented without an external perspective, this mediation requires an additional, transcendent mediator. In the website's database, its number is 0 and its name is "God" (see fig. 5, p. 34).

LEADER 1.1

Ernst Rüdiger Starhemberg, who came from an old noble family, was the federal leader of the Austrian Homeland Protection and initiator of the "Turks Deliverance Celebration" in Vienna on May 14, 1933. How did he conceive this idea?

EDITORIAL 1.2

The announced visit of German Nazi politicians in Vienna was "undesirable," the Christian Social *Reichspost* concluded in its editorial from May 9, 1933. The "Turks Deliverance Celebration," held the following weekend, should not be disturbed.

Fig. 36: The centralized network of the mediation “How to Use Reason: Sovereign Signs” in the Topology module of the website *campusmedius.net* (version 2.0/2021), designed by Susanne Kiesenhofer and adapted for the book edition by Stefan Amann.

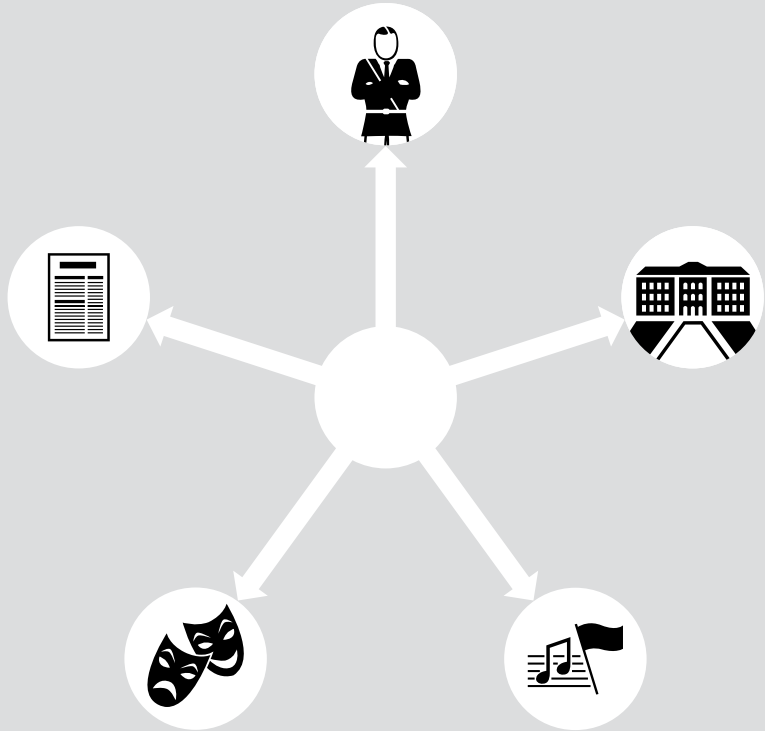

RESIDENCE

1.3

Why did the “Turks Deliverance Celebration” take place in the Baroque gardens of Schönbrunn? For a nationalistic rally of this type and scale, the Heldenplatz seems the more appropriate venue in Vienna, with its very name a military commemoration.

THEATER

1.4

In the evening before the “Turks Deliverance Celebration,” the drama *Hundred Days*, cowritten by Benito Mussolini, was performed at Vienna’s Burgtheater. How are the political rally and the theatrical production connected?

REFRAMING

1.5

How did it come to pass that at the “Turks Deliverance Celebration” one and the same melody—Joseph Haydn’s “Emperor’s Song”—was used for opposing aims, namely in support of the Austrian state’s preservation, as well as its annexation by the German Reich?

1.1 Leader: Ernst Rüdiger Starhemberg



place	Monument to Count Starhemberg
moment	Laying of a wreath
space	N 48.210411° E 16.359453°
time	1932 a 133 d 8 h 0 min p. Chr.

“For me it was, I admit, perhaps the proudest and best day of my political campaign,” Ernst Rüdiger Starhemberg wrote retrospectively of May 14, 1933.¹⁴⁵ As if the weather had anticipated the impending event and its impact, the sun burst through the clouds on this Sunday morning in Vienna and warmed the spring breeze until the afternoon, when heavy thunderstorms were accompanied by rain and hail.¹⁴⁶ Two years later Starhemberg remembered May 14, 1933, as the “eruption of the new era,” as the day “when 40,000 Homeland Protectors [*Heimatschützer*] saved the fatherland by marching in Schönbrunn.”¹⁴⁷ It was also the day, according to Starhemberg’s memoirs, that established his friendship with Engelbert Dollfuss, then federal chancellor of Austria.¹⁴⁸ However, when he dictated these memories to his secretary in the winter of 1938/39, Dollfuss was long dead and Starhemberg was in exile in France.

Before falling from grace, Starhemberg had risen to heady heights, and on the day in question he took a great leap up. In his eyes it was not only a turning point in his own life, but also in the history of Austria. For this reason he went into great detail about the preparations and the impact of May 14, 1933, in his memoirs, the first edition of which was published in

145 Ernst Rüdiger Starhemberg: *Die Erinnerungen*, Vienna/Munich: Amalthea 1991, p. 152 [our trans.].

146 See “Die amtliche Wettervorhersage,” in: *Neue Freie Presse* (Vienna), May 14, 1933 (morning edition), p. 14, and “Der Marsch durch Wien,” in: *Reichspost* (Vienna), May 15, 1933, p. 3.

147 Ernst Rüdiger Starhemberg: *Die Reden des Vizekanzlers E.R. Starhemberg*, Vienna: Österreichischer Bundespressediens 1935, pp. 75 and 84 [our trans.].

148 See Starhemberg: *Die Erinnerungen*, p. 152.

English in 1942.¹⁴⁹ According to this account, Starhemberg had a momentous conversation with Dollfuss in spring 1933.¹⁵⁰ The situation was extremely fraught because the National Socialists, having come to power in Germany at the beginning of the year, were also on the rise in Austria. Starhemberg allegedly advised Dollfuss that it was precisely at this point that one had to develop “an Austrian strength” that would give the people security and confidence.¹⁵¹ Whereas the federal chancellor was planning on holding a Christian Social Party conference as a large patriotic event, Starhemberg advocated a rally of the **Austrian Homeland Protection** (*Heimatschutz*), the paramilitary organization that he had overseen as its federal leader since 1930.

To secure financing for this mass rally, Starhemberg traveled to Rome to **Benito Mussolini**, whom he knew personally. According to his memoirs, he described to the Italian prime minister the plan for “a systematic wave of propaganda for Austria and against National Socialism.”¹⁵² Due to their shared language, “the Greater German feeling” was very pronounced in Austria, but precisely therein lay the critical issue: “We must finally muster the courage,” said Starhemberg, “to juxtapose the idea of a Greater Germany with an entirely unrelated idea of Austria.”¹⁵³ Allegedly, Mussolini emphatically welcomed this suggestion and named the concept of *italianità* in Fascist Italy as a model: “You must create something like that in Austria.”¹⁵⁴ Having already supplied weapons to the Austrian Home Guards (*Heimwehren*) at the beginning of the year, Mussolini now also provided the money for Starhemberg’s propagandist event.¹⁵⁵

149 See Ernst Rudiger Starhemberg: *Between Hitler and Mussolini*, New York/London: Harper & Brothers 1942.

150 Lothar Höbelt dates this conversation to April 7, 1933: *Die Heimwehren und die österreichische Politik 1927–1936. Vom politischen “Kettenhund” zum “Austro-Fascismus”?*, Graz: Ares 2016, p. 272.

151 Starhemberg: *Die Erinnerungen*, pp. 137–138 [our trans.].

152 Starhemberg: *Die Erinnerungen*, p. 139 [our trans.].

153 Starhemberg: *Die Erinnerungen*, pp. 139–140 [our trans.].

154 Starhemberg: *Die Erinnerungen*, p. 140 [our trans.].

155 The so-called “Hirtenberg arms incident” (*Hirtenberger Waffenaffäre*) was uncovered in the article “Italienische Waffen für Ungarn gehen über Österreich!,” in: *Arbeiter-Zeitung* (Vienna), January 8, 1933, p. 1. →

Fig. 43, p. 119

Although in the memoirs he wrote in exile, Starhemberg stresses that the rally was in opposition to National Socialism, he makes no secret of the fact that the event was also intended to seal the “abolition of degenerate democracy.”¹⁵⁶ In his view Austria was not mature enough for a democratic system of government in 1918, when the Habsburg Monarchy collapsed with the end of World War I. As stated by Starhemberg, hardly anyone had believed in the survival chances of the **small republic** that was left of the empire. The political parties had not been concerned about the country and its people, he continues, but rather about their own interests, which they had proclaimed at the top of their voices on the streets of Vienna and on the front pages of the newspapers: “The result was a parliamentarianism that became the stomping ground of rampant party demagoguery and wild battles for party-political gains at the cost of the population as a whole.”¹⁵⁷ When in March 1933 Dollfuss used a parliamentary crisis regarding the rules of procedure to start governing as a dictator using emergency decrees, he had simply “put an end to a circumstance that had become untenable.”¹⁵⁸

III.3.4

According to Starhemberg, therefore, a twofold sign was required in spring 1933: *for* Austria as an independent state with an authoritarian government and *against* Austria’s enemies, whether that be National Socialism, which wanted to absorb the country in a Greater German Reich, or **Social Democracy**, which was committed to establishing an international “dictatorship

→ Mussolini contributed 300,000 schillings to the rally in Schönbrunn on May 14, 1933, according to Höbelt: *Die Heimwehren und die österreichische Politik 1927–1936*, p. 272.

156 See Starhemberg: *Die Erinnerungen*, pp. 142–148 [our trans.].

157 Starhemberg: *Die Erinnerungen*, p. 146 [our trans.].

158 Starhemberg: *Die Erinnerungen*, p. 146 [our trans.]. In the session on March 4, 1933, all three presidents of the Austrian National Council had resigned in protest. The attempt to reconvene the interrupted session on March 15 was prevented by the police by order of the government. Federal Chancellor Dollfuss subsequently governed by means of emergency decrees on the basis of the Wartime Economy Enabling Act (*Kriegswirtschaftliches Ermächtigungsgesetz*) of 1917. See the conference proceedings edited by the Austrian Parliamentary Administration: *Staats- und Verfassungskrise 1933*, Vienna: Böhlau 2014.

of the proletariat.”¹⁵⁹ This sovereign sign would be made in the form of a mass rally by the Austrian Homeland Protection League (*Heimatschutzverband*), which Starhemberg staged as a “Turks Deliverance Celebration” (*Türkenbefreiungsfeier*). In 1933 Vienna’s liberation from the second Ottoman siege lay 250 years in the past. The state anniversary celebrations, however, only took place in late summer, in view of the fact that it was the famous Battle of Vienna on September 12, 1683, that had brought the roughly two-month siege to an end.¹⁶⁰ Why did Starhemberg call his event in May a “Turks Deliverance Celebration” contrary to historical fact? He does not explain his choice in his memoirs, but it can be assumed that his family history provides the reasons. Had the Habsburg Monarchy and with it the Austrian nobility survived World War I, then when his father Ernst Rüdiger died in 1927, the Starhemberg rank of prince would have gone to him, the Imperial Count von Starhemberg, who was born Ernst Rüdiger Camillo Maria on May 10, 1899, at Eferding Palace in Upper Austria.

The Starhemberg family was one of the oldest aristocratic dynasties in the Habsburg Monarchy.¹⁶¹ Its progenitor is believed to be a Gundacker from the twelfth century whose grandson of the same name built Starhemberg (Storichenberch) Castle on the Hausruck hills in Upper Austria from which the family later derived its surname. A crucial role in the family’s history was played by Erasmus I (1503–1560), who married Anna von

- 159 Starhemberg: *Die Erinnerungen*, p. 144 [our trans.]. The political opponents tried to substantiate the assertion that Austria was threatened by a “dictatorship of the proletariat” with the Austrian Social Democratic program that was adopted in Linz in 1926, which clearly committed the party to the democratic system of government but in the event of a bourgeois “counterrevolution” did not exclude “breaking the bourgeoisie’s resistance with the means of a dictatorship.” Cit. after “Das ‘Linzner Programm’ der Sozialdemokratischen Arbeiterpartei Österreichs, 1926,” in: Klaus Berchtold (ed.): *Österreichische Parteiprogramme 1868–1966*, Vienna: Verlag für Geschichte und Politik 1967, pp. 247–264, here p. 253 [our trans.].
- 160 On the cultural memory of the Ottoman siege of Vienna in 1683, see Johannes Feichtinger and Johann Heiss (eds.): *Geschichtspolitik und “Türkenbelagerung”* and *Der erinnerte Feind*, both Vienna: Mandelbaum 2013.
- 161 The following remarks are based on *Siebmacher’s Wappenbuch*, vol. 27: *Die Wappen des Adels in Oberösterreich*, Neustadt an der Aisch: Bauer und Raspe 1984 [1904], pp. 391–396.

City map of Vienna (1933 © Freytag & Berndt)

place	Monument to Count Starhemberg
moment	Laying of a wreath
space	N 48.210411° E 16.359453°
time	1932 a 133 d 8 h 0 min p. Chr.

mediations

- How to Use Reason: Sovereign Signs
- How to Capture Life: Examining Gazes
- How to Speak Up: Governed Transmissions

Fig. 37: Screenshot of the Topology module of the website campusmedius.net (desktop version 2.0/2021) showing the abstract of the mediator “Ernst

How to Use Reason: Sovereign Signs

LEADER

Ernst Rüdiger Starhemberg

Ernst Rüdiger Starhemberg, who came from an old noble family, was the federal leader of the Austrian Homeland Protection and initiator of the "Turks Deliverance Celebration" in Vienna on May 14, 1933. How did he conceive this idea?

READ MORE

Rüdiger Starhemberg” in the mediation “How to Use Reason: Sovereign Signs” (text: Simon Ganahl, code: Andreas Krimbacher, design: Susanne Kiesenhofer).

Schaunberg, meaning that the majority of the rich Schaunberg inheritance went to the House of Starhemberg. With his sons Rüdiger, Gundaker, and Heinrich, Erasmus founded the three main branches of the family, of which the Rüdiger lineage survives to the present day. Once the family, which had aligned itself with the Reformation, converted back to Catholicism, it was ennobled in 1643 to the rank of imperial count.

The family member most celebrated and honored as a national hero—not only in 1933—was called Count Heinrich Ernst Rüdiger von Starhemberg (1638–1701), who as military commander of Vienna had played a leading role in the city’s defense against the Ottoman troops in 1683. The grandson of his stepbrother Franz Ottokar, Georg Adam (1724–1807), who was the imperial ambassador to the French court and a confidant of Maria Theresa, was ennobled to the rank of imperial prince in 1765 by Emperor Joseph II. His grandson of the same name was childless, meaning that his property and princship passed to a distant cousin, namely Camillo Rüdiger von Starhemberg. Yet in 1927 his great-grandson Ernst Rüdiger, who fought on the Italian front in World War I and participated in the National Socialist putsch in Munich in 1923,¹⁶² only inherited the extensive family property: the parliament of the newly founded Republic of German-Austria had passed a law abolishing the nobility in 1919.¹⁶³

The so-called Law on the Abolition of the Nobility (*Adelsaufhebungsgesetz*), which still applies in Austria, prohibits the use of not only noble titles, but also noble coats of arms. That means that Ernst Rüdiger Starhemberg was neither allowed to refer to himself as the Seventh Prince von Starhemberg, nor was he permitted to wear the **Starhemberg coat of arms**, which illustrates on a visual level why he wanted to hold his propaganda event of May 14, 1933, as a “Turks Deliverance Celebration.”¹⁶⁴ The family’s original arms are considered to be the seal of the

Fig. 38, p. 107

162 See Gudula Walterskirchen: *Starhemberg oder Die Spuren der “30er Jahre,”* Vienna: Amalthea 2002, pp. 35–37.

163 See *Staatsgesetzblatt für den Staat Deutschösterreich* (StGBL.), 71/211 (April 10, 1919), pp. 514–515.

164 On the following, see *Siebmacher’s Wappenbuch*, vol. 27, pp. 390–391 and plates 100–101, as well as Johann Schwerdling: *Geschichte des Hauses Starhemberg*, Linz: Feichtinger 1830, pp. 33–37.

aforementioned Gundacker III, who built Starhemberg Castle in the thirteenth century. It is divided horizontally; in the top half there is a panther, which was initially green and later blue, on a silver or white background. This is the heraldic animal of the Styrian dukes whom Gundacker I, the Starhemberg progenitor, served as a knight. However, the heraldic panther, which remains a feature of the Styrian provincial coat of arms to this day, does not depict a black leopard, but rather a fire-breathing chimera formed from parts of various animals. The family arms were altered considerably in the mid-sixteenth century, when the Schaunberger arms were made over to the House of Starhemberg along with the inheritance.

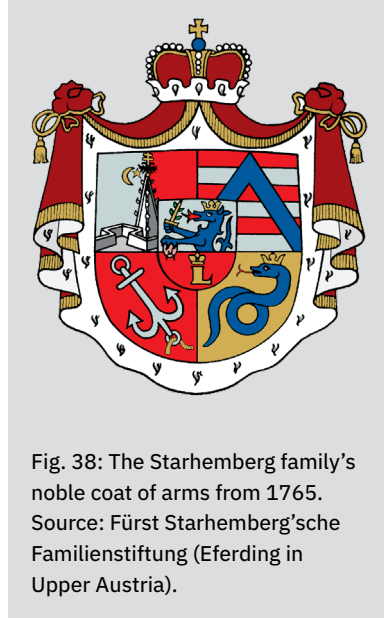

Fig. 38: The Starhemberg family's noble coat of arms from 1765. Source: Fürst Starhemberg'sche Familienstiftung (Eferding in Upper Austria).

Fig. 78, p. 196

After Vienna's liberation from the second Ottoman siege in 1683, Emperor **Leopold I** expressed his gratitude to the city's military commander, Count Ernst Rüdiger von Starhemberg, by conferring on him a further enhancement of his noble coat of arms: instead of three jousting helmets, the spire of Vienna's St. Stephen's Cathedral with its new double cross featuring a sunburst and crescent moon tumbling from its apex formed the crest of the now four-part coat of arms.¹⁶⁵

- 165 The so-called "moonlight" (*Mondschein*) was added to the spire of Vienna's St. Stephen's Cathedral in 1519 (for unknown reasons) and replaced with a Patriarchal cross first in 1686 and again the following year, this time over a double-headed eagle. On the sword in the clutches of the eagle stood the inscription: "Defendit Civitatem hanc contra Turcas Anno MDCLXXXIII Excellentissimus Dominus Ernestus Rudiger Comes à Starenberg, Generalis Campi Marschallus, et Commendans Viennae, ex benigno mandato Caesareo, et Cura Eminentissimi Domini S.R.E. Cardinalis Leopoldi à Kolloniz Episcopi Jaurinensis, qui obsidioni interfuit, Turri huic Aquila cum Cruce imposita est." (Defend this city against the Turks in →



Fig. 39: Ernst Rüdiger Starhemberg (ninth from the right) and Emil Fey (on his right) on the Rathausplatz in front of Vienna's City Hall at around 8 a.m. on May 14, 1933, before laying a wreath at the monument to Count Ernst Rüdiger von Starhemberg. Source: Austrian National Library, 66.253B.

On the two-part inescutcheon, the panther was given a sword wrapped in laurel in its left paw and a severed Turkish head (*Türkenschädel*) in its right; a gold, crowned L (for Emperor Leopold I) was added to the red lower half. The last alteration to the coat of arms was made in 1765 to commemorate the conferral of the princship to Georg Adam von Starhemberg. On this occasion, the panther, which now holds the Turkish head in its left and the sword in its right paw, is turned to face the opposite direction on the inescutcheon. In addition, the spire of St. Stephen's Cathedral no longer towers over the entire coat of arms but rather is located in the left (heraldic right) upper field behind a depiction of the bastion of Vienna, i.e., the city's fortifications constructed since the sixteenth century. This **final version** of the Starhemberg arms is topped by a princely crown and draped in a cloak lined with ermine.

Fig. 38, p. 107

Yet *de jure* is not the same as *de facto*—in other words, while the nobility had been abolished in Austria since 1919, the Home Guard members persistently addressed Starhemberg as Prince. Whether the Starhemberg arms were in fact displayed

- the year 1683 did His Excellency Ernst Rüdiger, Count von Starhemberg, field marshal general and commander of Vienna, by gracious order of the emperor, and under the custody of His Eminence, His Reverence the Cardinal Leopold von Kollonitz, bishop of Győr, who was present during the siege, the eagle with cross was mounted on this spire.) Cit. after Simon Hadler: "Stephansdom, Mondschein" [our trans.], in: Johannes Feichtinger and Johann Heiss (eds.): *Türkengedächtnis* (2010), URL: www.oew.ac.at/tuerkengedaechtnis/home/denkmaeler/ort/stephansdom-mondschein.

II.10 &
Fig. 74, p. 186

on one of the many flags waved at the “**Turks Deliverance Celebration**” in Vienna on May 14, 1933, is hard to confirm or indeed rule out. In any case, the following day the Austrian Homeland Protection’s press declared a great victory for their federal leader, “Prince Ernst Rüdiger von Starhemberg.” Thus the *Wiener Mittagsblatt* from May 15, 1933, twisted the historical facts when it stated:

Over 40,000 men showed yesterday, on the 250th anniversary of the deliverance of Vienna from the Turks, that they know: a quarter of a century [sic] after the great victory of the deliverers from the Turks, Austria’s fate is once again at stake. Vienna is once again besieged. But once again a Starhemberg is in the vanguard of the Austrian battalions. And once again the Austrian battalions prevail under a Starhemberg banner.¹⁶⁶

Fig. 39, p. 108

The celebrations began early in the morning, at 7:30 a.m., at the Liebenberg memorial opposite the University of Vienna, a victory monument erected in the 1880s in honor of Johann Andreas von Liebenberg, the Viennese mayor in 1683. Starhemberg first laid a wreath here, at the foot of the obelisk, and then marched with his assault company down the Ringstrasse to the **Rathausplatz** in front of City Hall, coming to a halt before another monument, namely that of Count Ernst Rüdiger von Starhemberg, where a further wreath was laid. Security Minister Emil Fey, who was also provincial leader (*Landesführer*) of the Viennese Homeland Protection, related Count Starhemberg’s campaign during the deliverance of Vienna in 1683 and described the critical role now being played by his descendant of the same name in the defense of Austria.¹⁶⁷

III.1.3

Around 10 a.m. Starhemberg arrived at Schönbrunn Palace, in whose **gardens** the actual “Turks Deliverance Celebration” opened with a Catholic Mass. Afterward Emil Fey had the floor, delivering the first speech in front of the legion Home Guard members who had arrived overnight from all over Austria

166 “Riesentriumph des Heimatschutzes!,” in: *Wiener Mittagsblatt* (Vienna), May 15, 1933, p. 2 [our trans.].

167 See “An Grossartigkeit alles übertroffen,” in: *Wiener Mittagsblatt* (Vienna), May 15, 1933, p. 3, and a report by the Federal Police Headquarters in Vienna from May 15, 1933, in the Austrian State Archives (ÖStA/AdR, BKA-I, 148.459/33).

by chartered trains. Fey, whom Dollfuss had included in his cabinet as his security minister at Starhemberg's recommendation, reminded the audience how in 1683 Count Starhemberg had understood how "to fill his soldiers and the citizens of Vienna with enthusiasm and his own heroic courage so that the well-nigh incredible actually came to pass, so that this then weak city could hold its ground against the vast Turkish army, could hold back this vast army." And 250 years later it was again an Ernst Rüdiger Starhemberg "who has assumed the leadership of many thousands of men who are loyal to their homeland and thirsty for battle, who have congregated in voluntary discipline and patriotism to protect the people and homeland."¹⁶⁸

Fig. 40, p. 111

II.13 & III.3.1

After this introduction Starhemberg himself began to speak. He wore the green uniform of the Homeland Protection, his medals pinned above his left breast pocket, under them the Silver Medal for Bravery First Class, which he had been awarded in World War I. Surrounded by his adjutants, invited guests, photographers, cameramen, and radio technicians, Starhemberg stepped onto the **speaker's podium** on the garden-side balcony of the palace in tall black leather boots and raised his right arm. The thousands of Home Guard members standing in formation in the Baroque gardens returned the greeting with cheers of "Heil." Once they had lowered their arms and the cheers had subsided, Starhemberg started his speech, which was broadcast live on *Radio Wien* and transmitted into the palace gardens by loudspeaker.

II.2

He reminded his supporters how often in the past the "Eastern March Germans" (*Ostmarkdeutschen*) had defended themselves "against a world of enemies," and highlighted three events that in his eyes were significant in world history: 1683, when "the Christian cross prevailed over the crescent moon"; the victory of "Austria's Germans" over the Napoleonic army at **Aspern** in 1809; and the "heroic deeds" of Austrian soldiers in the World War. Considering this valiant history, it was the duty of the Homeland Protection "to preserve the liberty and independence of our beautiful Austria, hallowed

168 Cit. after "Des Feindes Wogen gebrochen an Starhemberg," in: *Wiener Mittagsblatt* (Vienna), May 15, 1933, pp. 3–4 [our trans.].

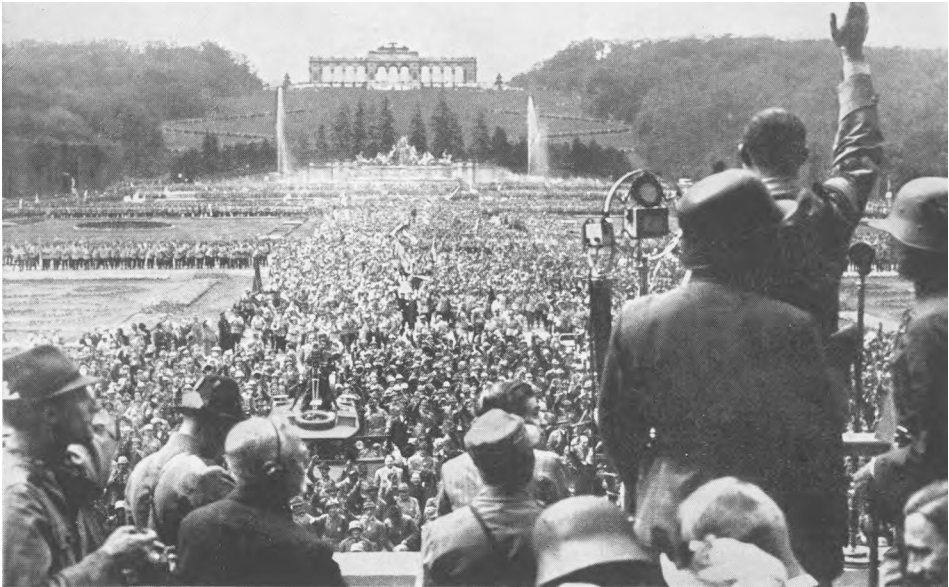

Fig. 40: The “Turks Deliverance Celebration” in the gardens of Schönbrunn Palace in Vienna on May 14, 1933: Ernst Rüdiger Starhemberg in front of the microphones; on his left a sound technician with headphones and a photographer with a Tyrolean hat; among the Home Guard men in the Great Parterre is the newsreel car of the Selenophon Licht- und Tonbild GmbH; in the background the Neptune Fountain and the Gloriette. Source: Austrian National Library, Pf 15.104 C9.

as it is by the death of thousands.” Since 1918, however, “party politics” and “class warfare” had demoralized the Austrian people, who needed a savior, demanded a savior. “Be that savior,” said Starhemberg to Federal Chancellor Dollfuss, “and be confident that everything supports you and everything is with you when you set about saving Austria.”¹⁶⁹

In his subsequent speech, Dollfuss also commemorated the historical events of 1683, yet he emphasized not only Count von Starhemberg but also the then barely twenty-year-old Prince Eugene of Savoy, who fought bravely in the Battle of Vienna and subsequently “warded off the danger of the Asian incursion into Western Christian civilization for all time.” However, after the World War, in which Dollfuss had himself performed his duty as a soldier at the front, the enemy had infiltrated the

169 Cit. after “Wir sind unbesiegtbar!,” in: *Wiener Mittagsblatt* (Vienna), May 15, 1933, p. 4 [our trans.].

Austrian people via “foreign ideas.” He wanted to fight these socialist ideologies and build a “Christian German state under the rule of law” whose population would be grouped according to profession. Finally, the federal chancellor pledged “**allegiance upon allegiance**” to “Prince Starhemberg,” the federal leader of the Austrian Homeland Protection, and ended his speech with the proclamation: “**Austria above everything, if she only will!**”¹⁷⁰

Fig. 41, p. 112

Fig. 70, p. 173 &
Fig. 71, p. 174

Starhemberg wrote in his memoirs that Dollfuss had repeated this oath of allegiance again in a tête-à-tête that evening. The federal chancellor was—as was he—deeply impressed by the rally in Schönbrunn and the **parade** that followed, during which “the hobnailed boots of our Alpine formations [marched] down Mariahilferstrasse into the city.”¹⁷¹ Starhemberg strode ahead of his Home Guard men before standing next to Dollfuss on **Schwarzenbergplatz** to review the parading troops who followed him.

III.2.1 &
Fig. 80, p. 197

II.15 &
Fig. 34, p. 93

Fig. 71, p. 174

The “**Fatherland Front**” (*Vaterländische Front*), which the federal chancellor had heralded during his speech in Schönbrunn, was founded just a week later as the Austrian state



Fig. 41: Propaganda poster (1934) by the Austrian Homeland Protection with a photograph of Ernst Rüdiger Starhemberg (left) and Engelbert Dollfuss, which was taken at the “Turks Deliverance Celebration” on the garden terrace of Schönbrunn Palace in Vienna on May 14, 1933. The text reads: “Build on the new Austria / Getting to work with Dollfuss / Starhemberg.” Source: Austrian National Library, PLA16307046.

170 Cit. after “Unser Weg ist der einzig richtige!,” in: *Wiener Mittagsblatt* (Vienna), May 15, 1933, pp. 4–5 [our trans., emphasis added].

171 Starhemberg: *Die Erinnerungen*, pp. 151–152 [our trans.].

party. While Dollfuss referred to the authoritarian regime that was now established in Austria as a “corporative state” (*Ständestaat*), Starhemberg expressly spoke of “Austrofascism.” In a speech entitled “Austria’s Path” (*Österreichs Weg*) that he held in March 1934 and subsequently had published, Starhemberg praised the ruthless course of action taken against the Republican Protection League (*Republikanischer Schutzbund*), the paramilitary organization of the Austrian Social Democratic Workers’ Party, which had been banned by Dollfuss and whose armed insurgency had just been violently countered by the Austrian Armed Forces, the police, and the Home Guards. He claimed that the Homeland Protection had bravely defended its fatherland in these critical February days of 1934 against “Austro-Bolshevism,” against this regional variant of Marxist false doctrines. Not only in Austria but around the world the “age of parliamentarianism” and of “democratic liberalism,” as well as of “individualist capitalism,” was drawing to an end.¹⁷²

*For this wave of renewal we know of no better umbrella term than Fascism. The basic principles that universally support this wave of renewal first took state form in Fascist Italy and found their expression in legislation. Consequently, when we say that we are supporters of Fascist ideas, it means that we want to achieve here in Austria that healthy, modern vision for the future that underlies Italy’s Fascist system of government.*¹⁷³

In Starhemberg’s opinion there were two reasons why the expression “corporative state” was an inadequate name for these radical political changes: First, because the new state had to prioritize the interests of the public over those of the individual professions; and second, because this public interest could only be enforced with corresponding authority in the state leadership. Incidentally, he continues, “Austrofascism” expressly adhered to the “Greater German idea,” though merely in the form of a friendly cooperation between independent and autonomous

- 172 Ernst Rüdiger Starhemberg: *Österreichs Weg*, Vienna: Österreichischer Heimatschutz 1934, pp. 4–6 [our trans.].
 173 Starhemberg: *Österreichs Weg*, p. 6 [our trans.].

states. The undeniable commonalities with National Socialism ended where Austria's sovereignty was called into question.¹⁷⁴

Then, on May 1, 1934, not only did the constitution of the Christian German “corporative state” heralded by Dollfuss during his speech in Schönbrunn come into force, but Starhemberg was also appointed its vice chancellor. Shortly afterward, on July 25, while the Home Guard leader was visiting Mussolini in Venice, Dollfuss was assassinated in the Federal Chancellery in Vienna by National Socialists during an attempted coup d'état.¹⁷⁵ Instead of ascending to the role of federal chancellor, Starhemberg voluntarily remained vice chancellor under former Justice and Education Minister Kurt Schuschnigg, though he was also appointed federal leader of the Fatherland Front.¹⁷⁶ On May 14, 1936, after he had congratulated Mussolini on the “victory of the Fascist spirit over democratic dishonesty and hypocrisy” during the Second Italo-Ethiopian War, which violated international law,¹⁷⁷ Schuschnigg removed him from office “due to a material difference of opinion”—three years to the day after the “Turks Deliverance Celebration.”¹⁷⁸ Both the Austrian federal chancellor and the Italian prime minister subsequently made a pact with Adolf Hitler, the chancellor of the German Reich. Starhemberg, by contrast, withdrew from politics to live a private life.

In December 1937 he traveled with his second wife, the then famous Burgtheater actress Nora Gregor, and their son Heinrich to the Swiss mountains for a skiing holiday. In late March 1938, roughly a fortnight after the German army had marched into Austria, Starhemberg sent a letter from Davos to Hitler, whom he had known personally since the 1920s. Contrary to his statements in his memoirs, in the letter he emphasized that it had always been the aim of the Homeland

174 Starhemberg: *Österreichs Weg*, pp. 9–11 [our trans.].

175 On the July Putsch, see Kurt Bauer: *Hitlers zweiter Putsch. Dollfuss, die Nazis und der 25. Juli 1934*, St. Pölten: Residenz 2014.

176 On Starhemberg's reluctant attitude after Dollfuss's death, see Walter Wiltschegg: *Die Heimwehr. Eine unwiderstehliche Volksbewegung?*, Vienna: Verlag für Geschichte und Politik 1985, p. 204.

177 Cit. after “Starhemberg beglückwünscht siegreichen Fascismus,” in: *Der Heimatschützer* (Vienna), 4/20 (May 16, 1936), p. 3 [our trans.].

178 See Wiltschegg: *Die Heimwehr*, p. 94 [our trans.].

Protection “to unite Austria with the German Reich as a single state entity.” Even though he was primarily asking for mercy for his comrades, Starhemberg stressed that he “was one of your fiercest supporters [as early as] in 1923” and now considered it his duty “to place myself at the disposal of you, my Führer, for the people and the fatherland.”¹⁷⁹ The offer went unanswered, but when Starhemberg started fighting against Germany from France in 1939, the National Socialists seized his property in Austria.¹⁸⁰

Exile took him and his family to South America, initially to Argentina, where he worked as a gaucho, then to Chile, where he lived with his son after the death of his wife. In the mid-1950s, when his assets were restituted to him despite vehement left-wing protests, Starhemberg returned home to Austria.¹⁸¹ He died of a heart attack only a few months later, on March 15, 1956, while staying at a health spa in Schruns in Vorarlberg, after a communist journalist had taken a photograph of him without his permission while he was out walking.¹⁸² A plaque was put up in his memory on the Litz chapel in Schruns where Starhemberg collapsed. In defiance of the law abolishing the nobility that has been in force since 1919, under the Starhemberg arms the copper plaque reads:

*Ernst Rüdiger
Prince Starhemberg
Vice Chancellor and Federal Leader
of the Austrian Homeland Protection*¹⁸³

- 179 Cit. after Ludwig Jedlicka: “Ernst Rüdiger Starhemberg und die politische Entwicklung in Österreich im Frühjahr 1938,” in: *Vom alten zum neuen Österreich. Fallstudien zur österreichischen Zeitgeschichte 1900–1975*, St. Pölten: Niederösterreichisches Pressehaus 1977, pp. 289–310, here pp. 305–308 [our trans.]. On Starhemberg’s Greater German or rather Greater Austrian position, see Wiltschegg: *Die Heimwehr*, pp. 210–212.
- 180 See Wiltschegg: *Die Heimwehr*, pp. 207–208.
- 181 See Wiltschegg: *Die Heimwehr*, pp. 208–209.
- 182 See “Ernst Rüdiger Starhemberg einem Herzschlag erlegen,” in: *Vorarlberger Nachrichten* (Bregenz), March 16, 1956, p. 1.
- 183 “Ernst Rüdiger / Fürst Starhemberg / Vizekanzler und Bundesführer / des Österreichischen Heimatschutzes.” A photograph of the plaque is available online at URL: phaidra.univie.ac.at/o:1079391.

1.2 Editorial: “Undesirable Visit”



place	<i>Reichspost</i> publishing building
moment	Publication of “Undesirable Visit”
space	N 48.207051° E 16.349469°
time	1932 a 128 d 6 h 0 min p. Chr.

Fig. 42, p. 117

On May 9, 1933, the Viennese *Reichspost* published an **editorial** entitled “Undesirable Visit” (*Unerwünschter Besuch*). It extends over the entire right column of the front page and continues in the upper third of the left and central column on page two of the daily newspaper. The article’s eight paragraphs are preceded by a location and date, namely “Vienna, on May 8,” but neither the author’s name nor their initials accompany the text.

The first paragraph refers to a notice by the “press office of the National Socialist Party for the gau of Vienna,” which had announced the “visit of several ministers of the German Reich,” including Bavarian Minister of Justice Hans Frank, in Vienna on May 13, 1933. This news is followed in the second paragraph by the argumentation that this was neither a declared ministerial visit nor an informal private visit. Rather, members of German federal state governments were coming to Austria without diplomatic agreement “to visit a party here and be celebrated by a party that opposes the constitutional government and state authority in an open battle not infrequently conducted with illegal means.” The third paragraph concludes that the party-political visit is not only “undesirable and unwelcome,” but must be considered a “hostile act” and treated accordingly.¹⁸⁴

In paragraphs four to eight the article then outlines its interpretation of the facts. The main speculation is that with this move an attempt was being made to circumvent the ban on public assemblies and marches and “to seriously disrupt

184 “Unerwünschter Besuch,” in: *Reichspost* (Vienna), May 9, 1933, pp. 1–2, here p. 1 [our trans.].



Fig. 42: The front page of the Viennese newspaper *Reichspost* published on May 9, 1933, with the editorial “Undesirable Visit” in the right column. Source: Austrian National Library, 393106-D.

II.10 The event mentioned was the “Turks Delivrance Celebration” (*Türkenbefreiungsfeier*) by the Austrian Homeland Protection League (*Heimatschutzverband*), which took place on May 14, 1933, in the gardens of Schönbrunn Palace. As Hans Frank had “deeply insulted the Austrian government and given notice of a violent intervention by Bavaria against Austria in a speech on the radio,” the authorities would need to clarify “whether he can even be permitted to stay on Austrian soil as a private citizen.” According to the article, it was beyond question

that the announced party politicians had to strictly abide by Austrian laws in the event of their arrival. The text closes by asking whether German Reich Chancellor Adolf Hitler, who had demonstrated “a high degree of discretion and moderation” in international politics, agreed with this “journey of party-political agitation by high-ranking state officials.” In any event, the necessary measures would in no way be targeted at the government of the German Reich, “but exclusively at the attempt by foreign guests to give new stimulus to subversive and antigovernmental agitation within our own borders.”¹⁸⁵

Fig. 43, p. 119

III.3.4

III.2.1

Fig. 41, p. 112

In clear and strict terms, the leading article opposed a violation of Austrian state sovereignty. Since the signing of the Treaty of Saint-Germain-en-Laye in 1919, **Austria** was no longer a multiethnic monarchy with a population of over fifty million, but a democratic republic whose approximately six and a half million, predominantly German-speaking residents lived on an eighth of the former state territory.¹⁸⁶ The independence of this comparatively small country was called into question across the political spectrum, on both the left and the right. While the **Social Democratic Workers’ Party** believed Austria should join the Weimar Republic, the NSDAP pushed for an authoritarian Greater German Reich. As such, it was primarily the Christian Social Party and the **Autrofascist Homeland Protection League** that wanted to preserve Austria as an independent state. The “Turks Deliverance Celebration” planned for May 14, 1933, in the Schönbrunn Palace gardens was intended to make a stand for a sovereign Austria under the leadership of the Christian Social Federal Chancellor **Engelbert Dollfuss**, who had been governing by emergency decree since March of that year.

But now the NSDAP’s Viennese press office had declared that National Socialist politicians from Germany—where Hitler had been Reich chancellor since late January 1933—would

185 “Unerwünschter Besuch,” pp. 1–2 [our trans.].

186 On the population numbers, see the results of the census in Austria-Hungary in 1910, as documented in the Austrian State Archives (ÖStA/AVAFHKA, MdI, Allg. Reihe, Zl. 42837/1910), and the *Statistisches Jahrbuch Österreichs 2018*, Vienna: Verlag Österreich 2018, p. 40. The Treaty of Saint-Germain-en-Laye from September 10, 1919, was published in the *Staatsgesetzblatt für die Republik Österreich* (StGBI.), 90/303 (July 21, 1920), pp. 995–1245.

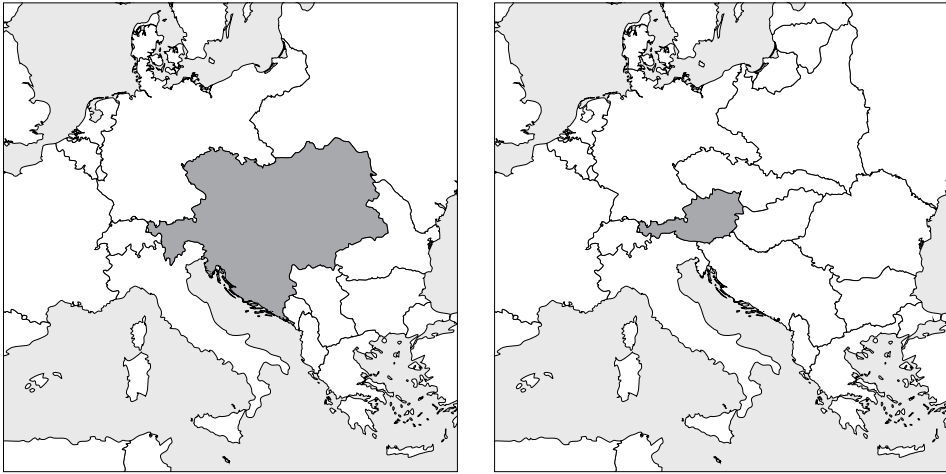

Fig. 43: The state territories of the Austro-Hungarian Monarchy in 1914 (left) and the Republic of Austria in 1919 (right), represented by Stefan Amann based on open data from Wikipedia.

visit that same weekend. The arrival of a number of members of German federal state governments had been announced, yet the visit had not been diplomatically arranged. As the leading article emphasizes, it was therefore not an official state visit. However, it was also not accurate to describe their stay in Austria as private, especially given the existence of this official party communiqué. Consequently, the visit had to be viewed as “a hostile act,” meaning a deed that, though not against international law, did fly in the face of international diplomacy, of comity.

According to the *Reichspost*, the impression of a breach of international convention was reinforced by the announcement that Hans Frank would be among the guests. Frank, who had carved out his career in the NSDAP as Hitler’s lawyer and would advance to governor-general of occupied Poland in World War II, was appointed Bavarian justice minister in March 1933 and in his new role gave a provocative speech on the radio against the Austrian government. Wolff Telegraphic Bureau, the official German news agency, quoted the respective part of the speech, which was broadcast on March 18, 1933, by the Munich radio station, as follows:

*Finally Dr. Frank gave his regards to his suppressed party comrades in Austria, who were obliged to endure the ultimate terror and the ultimate suppression under their government, whose irrationality was beyond his comprehension. Austria was now the last part of Germany in which one could still dare to suppress the will for a German nation. Amicably and with brotherly affection, he wanted to warn the Austrian government against, for example, giving the National Socialists occasion to protect the freedom of their fellow Germans in Austria.*¹⁸⁷

From the perspective of international law, the Bavarian justice minister had negated all the constitutive elements of the Austrian state in this speech.¹⁸⁸ Not only did he refer to the majority of the population as “fellow Germans” and the territory as “part of Germany,” but he also threatened to seize power. That Frank, who despite diplomatic protests had not apologized for this assault, now intended to come to Vienna, was an “insupportable test of the Austrian’s patience and good nature” according to the leading article in the *Reichspost*.¹⁸⁹

II.9 The bourgeois *Neue Freie Presse* reported right away, in its edition that evening, on the editorial about the “undesirable visit” in the “Viennese main organ of the Christian Social Party, whose statements in this case certainly cannot be viewed as a private opinion.”¹⁹⁰ The following day the Social Democratic *Arbeiter-Zeitung* addressed the “unusually vehement leading article” that had been published in the “government organ.”¹⁹¹ In subsequent editions the *Reichspost* quoted some of the aggressive reactions that their article had triggered in the Nazi press, such as the *Völkischer Beobachter* and the Berlin-based

187 Cit. after a memorandum of March 22, 1933, in the Political Archive of the Federal Foreign Office in Berlin (Office of the Reich Minister, reference 16: Austria, R 28392) [our trans.].

188 On the three elements concept of the state as people, territory, and authority, see Georg Jellinek: *Allgemeine Staatslehre*, 3rd ed., Berlin: Häring 1914 [1900], pp. 182–183.

189 “Unerwünschter Besuch,” p. 1 [our trans.].

190 “Der Streit Deutschland-Österreich geht weiter,” in: *Neue Freie Presse* (Vienna), May 9, 1933 (evening edition), p. 2 [our trans.].

191 “Unerwünschter Besuch,” in: *Arbeiter-Zeitung* (Vienna), May 10, 1933, p. 3 [our trans.].

Angriff, again clarifying that the expressed protest was not aimed at the government of the German Reich but against the party politics of the NSDAP in Austria.¹⁹²

II.1 &
Fig. 19, p. 57

The argumentation of the leading article, according to which the announced visit was “undesirable” for the reasons outlined above, led to consequences when the German politicians actually did arrive. At shortly after 2 p.m. on Saturday, May 13, 1933, Frank landed in a Lufthansa plane on **Aspern airfield** in Vienna along with Prussian Justice Minister Hanns Kerrl and the head of his ministry Roland Freisler, the future president of the German People’s Court of Justice. They were greeted not only by Nazi functionaries and roughly 1,500 onlookers, but also by Michael Skubl, the vice president of the Vienna police department, who according to the *Reichspost* officially informed Frank “that, in view of the still pending matters, the arrival of the minister of the federal government was ‘not especially welcome.’”¹⁹³ The visitors then drove in a convoy of dozens of cars and motorbikes, some adorned with swastika flags, to the **Adolf Hitler House**, the Vienna headquarters of the NSDAP. On their way they stopped at the **Lion of Aspern** to lay wreaths in front of the war memorial. Closer to the inner city, insults were hurled at the convoy, most loudly in the Leopoldstadt district near the **Lassalle Hof**, but it was also greeted with cheers, especially around the Adolf Hitler House in the **Mariahilf district**, where the vehicles arrived at around 4 p.m.¹⁹⁴

II.4
II.2 &
Fig. 20, p. 58

II.3 &
Fig. 21, p. 60
Fig. 22, p. 61

II.7 &
Fig. 25, p. 69

That same evening the visitors from Germany went on stage as speakers at a mass gathering in Vienna’s **Engelmann Arena**. From 8:30 to 10 p.m., just a few hours before the “Turks Deliverance Celebration” by the Austrian Homeland Protection in the gardens of Schönbrunn Palace, the National Socialists held their own rally to commemorate Vienna’s liberation from the

192 “Klarstellungen zum deutschen Ministerbesuch,”
in: *Reichspost* (Vienna), May 11, 1933, p. 3.

193 “Die nationalsozialistischen Fluggäste aus Deutschland,”
in: *Reichspost* (Vienna), May 14, 1933, p. 8 [our trans.].

194 See the reports in the Viennese newspapers *Reichspost* (May 14, 1933, p. 8), *Das Kleine Volksblatt* (May 14, 1933, p. 4), *Deutschösterreichische Tages-Zeitung* (May 14, 1933, pp. 1 and 3), *Die Rote Fahne* (May 14, 1933, p. 2), *Wiener Zeitung* (May 14, 1933, p. 6), and *Neue Freie Presse* (May 14, 1933, morning edition, p. 7).

Ottoman siege in 1683.¹⁹⁵ At both events facts were irrelevant: although the city had indeed been successfully defended from the Ottoman troops 250 years previously, that did not happen in May but from mid-July to mid-September 1683. Besides, the historical events served merely as a backdrop for contemporary political conflicts, as Hans Frank expressly stressed:

*Though I was not involved in Vienna's deliverance from the Turks, I have learned from the press that my task today is allegedly to speak about Vienna's deliverance from the Turks. I had a similar topic in mind, but I would not have chosen the Turks. I can imagine that a city's liberation is abundant cause for a celebration and I am already looking forward to taking part in a good celebration of Vienna at some point.*¹⁹⁶

II.14 &
Fig. 33, p. 91

Frank also pleaded the case for Austria and its capital city belonging to the German Reich in a press conference held at noon the following day, May 14, 1933, at the **German embassy** in Vienna. That afternoon he drove to Graz where he gave a speech on the Schlossberg opposing the Austrian federal government. However, instead of making a public appearance in Salzburg on Monday, May 15, 1933, as planned, a police injunction obliged Frank to leave the country and return to Germany.¹⁹⁷

Fig. 43, p. 119

At first glance it is astounding that a newspaper called *Reichspost* advocated the sovereignty of the **Austrian Republic** in 1933. Even its subtitle, namely "Independent Daily Paper for the Christian People" (*Unabhängiges Tagblatt für das christliche Volk*) does not help explain this defensive role, instead raising the additional question of why the *Neue Freie Presse* and the *Arbeiter-Zeitung* referred in their commentaries on the leading article to the "main organ of the Christian Social Party" and the "government organ." However, both matters are explained by

195 See "Überwältigende Feier in der Engelmann-Arena," in: *Deutsch-österreichische Tages-Zeitung* (Vienna), May 14, 1933, p. 2, and a report by the Federal Police Headquarters in Vienna from May 14, 1933, in the Austrian State Archives (ÖStA/AdR, BKA-I, 148.459/33).

196 Cit. after "Überwältigende Feier in der Engelmann-Arena," p. 2 [our trans.].

197 See "Abreise der deutschen Funktionäre," in: *Neue Freie Presse* (Vienna), May 15, 1933 (evening edition), p. 4; "Ersuchen um Rückberufung Dr. Franks," in: *Reichspost* (Vienna), May 16, 1933, p. 1; "Die Heimreise Dr. Franks," in: *Neue Freie Presse* (Vienna), May 16, 1933 (evening edition), p. 2.



Fig. 44: Screenshot of the Topology module of the website campusmedius.net (mobile version 2.0/2021) showing the mediator “Undesirable Visit” in the mediation “How to Use Reason: Sovereign Signs” (text: Simon Ganahl, code: Andreas Krimbacher, design: Susanne Kiesenhofer).

Fig. 45, p. 127

the history of the newspaper, whose founding dated back to a resolution by the Linz Catholic Convention of 1892 to publish a modern Christian newspaper for the Austro-Hungarian Monarchy.¹⁹⁸ After some trial issues and flyers in the course of 1893, the *Reichspost* was published daily from January 1, 1894. **Friedrich Funder**, the editor in chief and editor of the newspaper for many years, explained in his memoirs how its programmatic title should be interpreted:

*The paper saw its responsibility as extending to the empire and all its nations. Its slogan was intended to be a powerful affirmation of the Habsburg Empire's notion of the state in opposition to all separatists and nationalistic mavericks.*¹⁹⁹

Fig. 43, p. 119

Hence, the *Reichspost* was aimed at the entire population of the monarchy but claimed the German Austrians' leadership over citizens with other mother tongues. The "Reich" of the newspaper's title was not a nation, not a homogeneous people, but rather an **expansive territory in Central Europe** whose heterogeneous components were kept together by the emperor, the sovereign. The reference in the subtitle that it was a "Daily Paper for the Christian People" meant that the *Reichspost* was in opposition to the liberal, in its opinion "Jewish," press on the one hand and to the Social Democratic newspapers on the other. In contrast to the *Arbeiter-Zeitung*, the main organ of Austrian Social Democracy since 1889, the *Reichspost* claimed to be independent. In point of fact, however, it had always functioned as a mouthpiece for the Christian Social movement, which had been constituted as a political party in 1893 under future Mayor of Vienna Karl Lueger.²⁰⁰

Above all it was Funder's personal connections that linked the paper ever closer to the Christian Social Party. Born in Graz in 1872, he arrived at the *Reichspost* as a law student in 1896, soon carved out a career for himself in its small editorial team in Vienna, and was appointed editor in chief in 1902 and

198 See Friedrich Funder: *Vom Gestern ins Heute. Aus dem Kaiserreich in die Republik*, 3rd ed., Vienna/Munich: Herold 1971 [1952], p. 44.

199 Funder: *Vom Gestern ins Heute*, p. 124 [our trans.].

200 See Hedwig Pfarrhofer: *Friedrich Funder. Ein Mann zwischen Gestern und Morgen*, Graz: Styria 1978, pp. 44 and 132–138.

two years later its editor, too. Following Lueger, Funder openly advocated a “Christian antisemitism” in numerous leading articles denouncing cultural and economic influences from Judaism, but expressly dissociating the paper from the racial antisemitism of the “Pan-Germanists” (and later of the National Socialists).²⁰¹ As Funder was one of Franz Ferdinand’s advisers and supported his Greater Austrian reform plans, the *Reichspost* reacted vehemently to the murder of the Austro-Hungarian heir to the throne in 1914 and its journalism fueled the outbreak of World War I.²⁰² In the 1920s, the newspaper evolved into a kind of organ of the government because all the federal chancellors of the newly created Republic of Austria, with the exception of Karl Renner and Johann Schober, came from the Christian Social Party.

The politics of Ignaz Seipel in particular met with Funder’s unreserved support. Seipel was not only a moral theologian and chairman of the Christian Social Party, as well as federal chancellor and federal minister twice, but since 1917 he had also been on the board of the Catholic publishing house Herold, which issued the *Reichspost*.²⁰³ The newspaper welcomed Seipel’s anti-Marxist policy and his advocacy of the Austrian Home Guards, which he encouraged as a “bulwark against Bolshevism.” Hence it is unsurprising that the *Reichspost* supported Federal Chancellor Engelbert Dollfuss from the outset, another friend of Funder’s.²⁰⁴ As the semiofficial mouthpiece of the Dollfuss cabinet, from March 1933 the newspaper championed the establishment of an “authoritarian democracy,” which should be organized as a “corporative state” (*Ständestaat*).²⁰⁵ With this pro-government editorial policy, the *Reichspost* attempted to dissociate itself from the emerging Nazi dictatorship in Germany on the one hand and from the political opponents in Austria on the other, who would

201 On this notion of “Christian antisemitism,” see the programmatic editorial “Christlicher und Rassen-Antisemitismus,” in: *Reichspost* (Vienna), July 8, 1897, pp. 1–2.

202 See Pfarrhofer: *Friedrich Funder*, pp. 51–85.

203 See Funder: *Vom Gestern ins Heute*, pp. 256–257.

204 See Pfarrhofer: *Friedrich Funder*, pp. 176–181.

205 See, for example, the editorial “Aufbruch!,” in: *Reichspost* (Vienna), March 3, 1933, p. 1.

allegedly abuse parliamentarianism and freedom of opinion for strategic party-political purposes.

Fig. 45, p. 127

Fig. 46, p. 128
Fig. 44, p. 123 &
Fig. 47, p. 128

In his memoirs, in which he discusses the *Reichspost* a great deal, Funder compares a newspaper to a state: “under a unified leadership its administration is divided into specialized fields that have their respective experts and comprise all areas of human activity.”²⁰⁶ The comparison is apparently not based on a democratic form of government but on a “**corporative state**” as envisaged by Dollfuss. While authoritarian leadership is the responsibility of the federal chancellor or editor in chief, human activities are uniformly represented by professions or departments. This representative administration was also expressed in the infrastructure of the *Reichspost*, which in 1913 moved within Josefstadt, Vienna’s eighth district, from **Strozzigasse 41**, a small suburban building, to **Strozzigasse 8**, where the new Herold publishing house was constructed on lot of around one thousand square meters. The building’s communication center, designed as a “representative space,” comprised the office of the editor in chief, who had at his command the “master station” of the American telephone system and was able to send manuscripts straight to the composing room by pneumatic dispatch.²⁰⁷

In Funder’s opinion a print newspaper should be headed by a leading article in the same way that the state required a leader and the editorial team an editor in chief. For this reason, the editorial was always printed on the front page in the *Reichspost*, followed by the day’s political, local, ecclesiastical, cultural, and financial news and opinion pieces, as well as by the classified section at the back. Although this genre of journalistic text, which critically comments on an aspect of current affairs in the name of the newspaper or periodical, can be traced back to the early eighteenth century, the term “leading article” or “editorial” only emerged in the early nineteenth century.²⁰⁸ The reason is the formally leading role of

206 Funder: *Vom Gestern ins Heute*, p. 125 [our trans.].

207 See “Das neue Heim der ‘Reichspost,’” in: *Reichspost* (Vienna), December 7, 1913, pp. 4–7.

208 See Carin Gentner: “Zur Geschichte des Leitartikels,” in: Winfried B. Lerg, Michael Schmolke, Gerhard E. Stoll (eds.): *Publizistik im Dialog*, Assen: van Gorcum 1965, pp. 60–68.



Fig. 45: Friedrich Funder giving a speech in front of representatives of the Austrian “corporative state,” among them Kurt Schuschnigg (with glasses) and Theodor Innitzer (with skullcap) in the middle of the front row, photographed in 1935 in the publishing building of the *Reichspost* at Strozzigasse 8 in Vienna. Source: APA Picturedesk, 19350101_PD10677.

the article, which only became possible when newspapers no longer printed a series of news items, but different departments and then front pages with the day’s headlines emerged.

Typically, therefore, the leading article can be found on the front page and comments on the item in the newspaper that the editorial team considers most important. In its leading position it is intended to guide both the subsequent articles and the reading process. As is shown by “Undesirable Visit,” the editorial does not perform this leadership task in terms of content alone. More than just telling the readers *what* they should think, the leading article demonstrates *how* to think. It starts with a particular occasion or event, a current news item, approaches it from different angles, and ultimately takes up a specific position. Every day this process—from facts to argumentation to interpretation—demonstrates how a judgment is formed. Whereas the essays of the London-based magazines in the early eighteenth century—such as in Daniel Defoe’s *Review* or Jonathan Swift’s *Examiner*—were mostly attempts to approach a matter subjectively,²⁰⁹ the strict format of the editorial prescribes a general thought pattern. As a rule it is not an individual, not an author, but the collective imagination of a newspaper that represents a part of reality in the leading article.

209 See J.A. Downie and Thomas N. Corns (eds.): “Telling People What to Think. Early Eighteenth-Century Periodicals from *The Review* to *The Rambler*,” in: *Prose Studies*, 16/1 (1993).



Fig. 46: The old editorial office and publishing building of the newspaper *Reichspost* at Strozzigasse 41 in Vienna around 1900. Source: Archive of the Herold Druck und Verlag GmbH (Vienna).



Fig. 47: The new editorial office and publishing building of the newspaper *Reichspost* at Strozzigasse 8 in Vienna in 1927. Source: Archive of the Herold Druck und Verlag GmbH (Vienna).

There may have been technical reasons behind Funder's demand for sovereign leadership and representative order, whether of the state or of the newspaper, as the printing process showed him every day an imminent confusion of characters. His memoirs include this vivid passage about the work of the *Reichspost* in the old editorial building at Strozzigasse 41 in Vienna:

Even here on Strozzigasse the newspaper was not produced with composing machines but manually typeset from the type case. If the typesetter became nervous while assembling the composition and pulled hastily on the cords that held together the manually typeset form of fifteen to twenty lines, then corners or entire lines of loose sorts fell out: the result was time losses, mutilated words when the damaged part of the form was hurriedly repaired, and even greater nervousness among those involved. A hand-operated

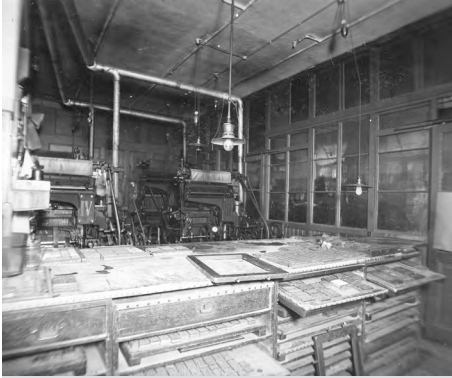

Fig. 48: Composing room of the newspaper *Reichspost* with typesetting machines in the background, photographed in the new publishing building at Strozzigasse 8 in Vienna after 1913. Source: Archive of the Herold Druck und Verlag GmbH (Vienna).

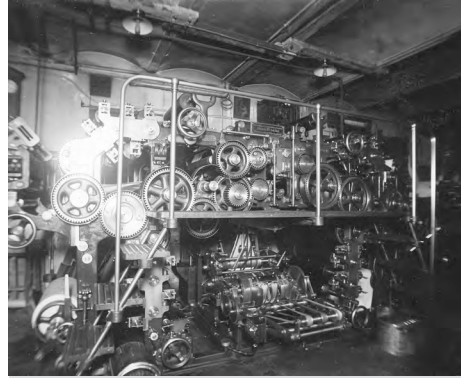

Fig. 49: Rotary printing press of the newspaper *Reichspost*, produced by the Schnellpressenfabrik Frankenthal, Albert & Co. AG, photographed in the old publishing building at Strozzigasse 41 in Vienna before 1913. Source: Archive of the Herold Druck und Verlag GmbH (Vienna).

*winch lowered the form down to the lead foundry on the ground floor, a gigantic cave that adjoined the machine room. This housed the pride of the building, the rotary printing press, a neat Augsburg product, as shiny as silver.*²¹⁰

Fig. 48, p. 129

Fig. 49, p. 129

At the Vienna *Reichspost* around 1900, the movable sorts were taken from the **type case**, set back to front into the composing stick, and spaces added to create a multiline piece of justified text in much the same way as Johannes Gutenberg had developed his printing process in the mid-fifteenth century. The finished manually typeset form made of lead had to be tied together tightly by the typesetter in order to be winched down to the stereotyping department, where the masters and the flongs for the **rotary press** were cast. If the typesetter was clumsy or nervous, the sorts either fell apart entirely or at least became disarranged, resulting in nonsense on the printed page. In accordance with Funder's typographic experience, it was therefore necessary to keep these arbitrary signs together, literally to form them. Otherwise the rational representation—as exemplarily embodied in the editorial—dissolved into utter chaos.

1.3 Residence: Schönbrunn



place	Schönbrunn Palace gardens
moment	Deployment of Home Guard troops
space	N 48.183006° E 16.311253°
time	1932 a 133 d 9 h 0 min p. Chr.

- II.10 Why did the “**Turks Deliverance Celebration**” (*Türkenbefreiungsfeier*) by the Austrian Homeland Protection (*Heimatschutz*) on May 14, 1933, take place in Schönbrunn? For a nationalistic rally of this type and scale, the Heldenplatz seems the more appropriate venue in Vienna, with its very name (literally “Heroes’ Square”) a military commemoration. After all, the speeches that were given expressly emphasized the merits of Prince Eugene of Savoy in the campaigns against the Ottomans and the Battle of **Aspern** in 1809, when, under Archduke Charles, Austrian troops defeated Napoleon’s army for the first time.²¹¹ **Ernst Rüdiger Starhemberg**, the federal leader of the Homeland Protection, and Federal Chancellor Engelbert Dollfuss were thus praising those two historic “heroes” who had been eternalized as equestrian statues on the square in front of the Hofburg Palace in Vienna. So why choose the Baroque palace with its French garden and not the heroic memorial site in the city center?
- II.2
- III.1.1

- III.2.1 The Austrian State Archives seem to offer an answer. A letter has been preserved there with which the federal leadership of the **Homeland Protection League** (*Heimatschutzverband*) applied to the Palace Captainship (*Schlosshauptmannschaft*) for permission to hold the “Turks Deliverance Celebration,” which was planned for May 14, 1933, in Schönbrunn. “As it has transpired that the Heldenplatz is too small for the masses of expected participants,” the letter from April 13, 1933, states, “the federal leadership requests the use of the parterre in front of Schönbrunn Palace (garden side) in order to provide this

211 See *Wiener Mittagsblatt* (Vienna), May 15, 1933, pp. 4–5.

patriotic event with an appropriate, worthy setting.”²¹² It was anticipated that 20,000 to 25,000 Home Guard (*Heimwehr*) members would attend. The Palace Captainship subsequently recommended that the Ministry of Trade and Transport grant the application “by way of exception” under the condition that all costs be borne by the event organizer and the gardens be reliably protected from any damage. The federal leadership of the Homeland Protection duly received the corresponding authorization from the ministry in late April.²¹³

In principle, Schönbrunn had been closed to events since 1924. This explains why the Homeland Protection League had to apply to the Palace Captainship and the Ministry of Trade and Transport for this special permit. For example, the previous year, the Vienna gau administration (*Gauleitung*) of the NSDAP had wanted to hold a political rally in Schönbrunn but was ordered instead to use the Heldenplatz.²¹⁴ In the case of the “Turks Deliverance Celebration” of May 14, 1933, the approval presumably came from the top, because Starhemberg mentions in his memoirs that he obtained it from Dollfuss directly.²¹⁵ However, he does not explain why the rally was supposed to take place in Schönbrunn. Was it really because Heldenplatz was not big enough? This argument is not very cogent, considering that events were indeed held there in the interwar period with well over 25,000 participants. During the state funeral for Dollfuss on August 8, 1934, some 200,000 people were said to have gathered on Heldenplatz and the nearby Ringstrasse,²¹⁶ and when on March 15, 1938, Hitler declared from the balcony

- 212 Letter from the Austrian Homeland Protection to the Palace Captainship Schönbrunn, dated April 13, 1933, in the Austrian State Archives (ÖStA/AdR, BM.f.H.u.V., GZ 53, Z 61.738-1933) [our trans.].
- 213 See the letters from the Palace Captainship Schönbrunn to the Federal Ministry of Trade and Transport, dated April 15, 1933, and to the Austrian Homeland Protection League, dated April 28, 1933, in the Austrian State Archives (ÖStA/AdR, SHS 820/1933, Kt. 86) [our translation].
- 214 See Judith Brocza and Christian Stadelmann: *Die Leute von Schönbrunn. Über die Nutzung des Schlosses im 20. Jahrhundert*, Vienna: Schloss Schönbrunn 2000, p. 62.
- 215 See Ernst Rüdiger Starhemberg: *Die Erinnerungen*, Vienna/Munich: Amalthea 1991, p. 151.
- 216 See “Überwältigende Trauerkundgebung auf dem Heldenplatz,” in: *Reichspost* (Vienna), August 9, 1934, p. 1.

of the Neue Burg section of the Hofburg Palace that Austria now belonged to the German Reich, it is estimated that up to 300,000 people had congregated to listen to him.²¹⁷

Due to this relative lack of evidence, we can only speculate as to the real reasons for holding the “Turks Deliverance Celebration” in Schönbrunn. Several motives are conceivable, however, and two of them will be discussed in detail below: the historical connection between the “deliverance from the Turks” and the construction of the palace, and the centralized arrangement of leaders and troops in the geometric garden.²¹⁸

As early as the Middle Ages, mills had been built in what are now the palace grounds, which lie along the river Wien between the former villages and now city districts of Hietzing to the west and Meidling to the east.²¹⁹ The plot of land known as Katterburg belonged to the estate of Klosterneuburg Monastery, which sold it to Emperor Maximilian II in 1569. He then set up a hunting reserve on the premises where, according to legend, one of his sons, the future Emperor Matthias, found the “beautiful spring” (*schöner Brunnen*) that gave the Habsburgs’ stately home its name. After the death of Ferdinand II, his widow, Eleonora Gonzaga, had the manor house at the foot of the hunting grounds converted into a palace, which G.M. Vischer depicted as the “Imperial Pleasure Garden and Hunting Grounds of Schenbrunn” (*Khaiserlicher Lust- und Thiergarten Schenbrunn*). Published in 1672, this **copperplate engraving** shows the Katterburg on the river Wien, which was extended to the right with the Gonzaga wing between 1640 and 1645. Behind it the hunting grounds stretched over the Schönbrunn hill; in the mid-1660s, the stations of the cross were incorporated in its northern wall, which is visible by the river in the lower section of Vischer’s engraving.

Fig. 50, p. 133

- 217 See Peter Stachel: *Mythos Heldenplatz. Hauptplatz und Schauplatz der Republik*, Vienna: Molden 2018, p. 45.
- 218 Another probable reason was the possibility to march from the former summer residence of the Habsburgs into the center of “Red Vienna,” which was governed by the Social Democrats (see chap. III.2.1).
- 219 On the building history of Schönbrunn, see the overview in Herbert Karner: “Vom Jagdschloss zur Sommerresidenz. Die Baugeschichte des Schlosses von seinen Anfängen bis 1918,” in: Franz Sattler (ed.): *Schönbrunn*, Baden: Edition Lammerhuber 2017, pp. 136–163.



Fig. 50: Copperplate engraving of the imperial gardens of Schönbrunn by Georg Matthäus Vischer, printed in his *Topographia Archiducatus Austriae Inferioris Moderna*, vol. 1: *Das Viertel unter Wienerwald*, Vienna 1672, fig. 91. Source: Vienna University Library, II-177773/1.

Fig. 78, p. 196

Fig. 51, p. 134

In summer 1683, during the siege of Vienna by the Ottoman troops, the palace and garden of Schönbrunn were laid waste.²²⁰ No notable improvements were made to this condition in the years after the successful defense of the city, as the reconstruction of the Hofburg Palace and other imperial residences took precedence. However, in 1688 the sculptor Johann Bernhard Fischer from Graz, who had trained as an architect in Rome, presented a design for an imperial palace to **Leopold I** that was to be constructed in Schönbrunn. It can be presumed that Fischer hoped to achieve two things with this oversized project, namely on the one hand to demonstrate his architectural skill and on the other to design a residence that would befit the House of Habsburg. In the **engraving of the design**, which was produced by Johann Adam Delsnbach and published by Fischer in 1721, several terraces lead from the river Wien up to the palace, which is positioned on the crest of the Schönbrunn hill like an otherworldly object.

220 See Elisabeth Hassmann: *Von Katterburg zu Schönbrunn. Die Geschichte Schönbrunn bis Kaiser Leopold I.*, Vienna: Böhlau 2004, pp. 372–378.

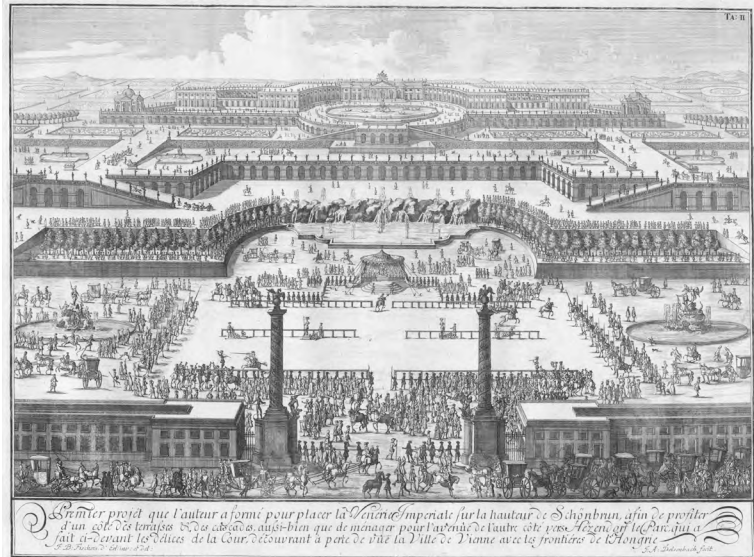

Fig. 51: Engraving of the first, not realized Schönbrunn project (1688) by Johann Bernhard Fischer von Erlach, printed in his *Entwurf einer historischen Architectur*, Vienna 1721, book IV, plate II. Source: ETH Library (Zurich), Rar 758.

The literature often compares Fischer's Schönbrunn project from 1688 with the Palace of Versailles, which Louis XIV had converted into a residence from the 1660s.²²¹ In competition with the French king, who famously styled himself as the *Roi-Soleil*, references to the architecture of antiquity and the sun god Apollo were intended to stress that the Habsburgs were in fact the legitimate heirs of the Roman emperors.

Although this *premier projet* for Schönbrunn was never realized, Fischer was appointed the architecture teacher of the heir to the throne the following year, 1689.²²² For him, the future Emperor Joseph I, he now planned a feasible hunting retreat (*Jagdschloss*), which was constructed from the mid-1690s on the site of the Katterburg and integrated elements of the original building. According to an engraving published

Fig. 52, p. 135

221 See, for example, Hans Sedlmayr: *Johann Bernhard Fischer von Erlach*, Stuttgart: DVA 1997 [1976], pp. 74–77.

222 See Hellmut Lorenz: *Johann Bernhard Fischer von Erlach*, Zurich: Verlag für Architektur 1992, p. 172.



Fig. 52: Engraving of the second, mostly realized Schönbrunn project (1696) by Johann Bernhard Fischer von Erlach, printed in his *Entwurf einer historischen Architectur*, Vienna 1721, book IV, plate III. Source: ETH Library (Zurich), Rar 758.

by Fischer, the path to the retreat led through a gate with two obelisks, across a spacious cour d'honneur, to a rounded ramp from which guests could access—via a perron—first a columned hall and then the ballroom of the bel étage, which on the opposite side offered a prospect of the garden. In Fischer's floor plan, the state and private apartments are arranged in an enfilade, meaning threaded (French *enfiler*) along an axis, in the right, west wing. In fact, the initial plan only envisaged the construction of the central wing, the corps de logis with its seventeen axes, which was opened amid festivities in spring 1700. However, two wings were subsequently added to the retreat at the suggestion of Leopold I in order to accommodate the entire court. In other words, around 1700 Schönbrunn had been upgraded from a mere hunting retreat or pleasure-house (*Lustschloss*) to an imperial residence.²²³

Yet the premature death of Joseph I in 1711 meant that this construction work remained unfinished. Only in 1743 did Maria Theresa decide not only to have Schönbrunn restored

Fig. 52, p. 135

but to finally have it converted into a summer residence.²²⁴ Consequently, under the direction of the architect Nikolaus Pacassi, the ballrooms in the corps de logis were restructured, for example, and the imperial apartments relocated to the east wing. Instead of the access ramp designed by Fischer, two curved perrons were constructed on each side, which made it possible for carriages to travel unhindered across the cour d'honneur, through the palace, and straight into the garden. Imperial Garden Engineer (*Garteningenieur*) Jean Trehet had already started laying out the palace gardens in 1695.²²⁵ He took Fischer's schematic **garden design**, which was still in the tradition of the Renaissance with its beds arranged in a square grid, merely as a guide. Instead, the Parisian Trehet realized a French Baroque garden, which combined parterres and bosquets, i.e., level flower beds and formal hedges. While Maria Theresa devoted herself to the alteration of the palace building in the mid-eighteenth century, her husband Francis I Stephen, supported by experts from his homeland of Lorraine, turned his attention to the redesign of the palace gardens.²²⁶ Among other things, he had the **Great Parterre** elongated to the foot of the Schönbrunn hill and added to the right-angled network of avenues two large diagonal axes, which radiate from the palace into the garden as a *patte d'oie*, meaning in the shape of a goose's foot. In 1779, a year before Maria Theresa's death, the majority of Schönbrunn's gardens were opened to the public.

Fig. 53, p. 137

Fig. 79, p. 196

The status of the palace grounds subsequently became dependent on both the political climate and the personal preferences of the respective ruler. Generally speaking, however, Schönbrunn served as a regular summer residence for the Habsburg emperors in the nineteenth century.²²⁷ **Francis Joseph I** was born in the palace in 1830 and spent much time in the gardens in his childhood and youth. During his reign,

224 See Karner: "Vom Jagdschloss zur Sommerresidenz," p. 155.

225 See Beatrix Hajós: *Die Schönbrunner Schlossgärten. Eine topographische Kulturgeschichte*, Vienna: Böhlau 1995, pp. 23–24.

226 See Hajós: *Die Schönbrunner Schlossgärten*, pp. 27–29.

227 See Karl Vocelka: "Die Herrschaft der Habsburger. Wie ein Schloss zum Symbol der Dynastie wurde," in: Franz Sattler (ed.): *Schönbrunn*, Baden: Edition Lammerhuber 2017, pp. 98–129, here pp. 119–128.



Fig. 53: Bernardo Bellotto (called Canaletto): *The Imperial Pleasure-House Schönbrunn, Garden Side* (1759/60). Source: Kunsthistorisches Museum (Vienna), GG 1667.

the residential and working areas were located in the west wing of the building; a private apartment for his wife Elisabeth was set up on the ground floor. After Francis Joseph's death in Schönbrunn in 1916, his successor, Charles I, planned alterations to the palace, which would never come to pass. Instead, the last Habsburg emperor abdicated in the fall of 1918, shortly before World War I officially came to an end, handing power to the representatives of the newly founded Republic of German-Austria, and emigrated to Switzerland with his family the following spring.

By law, all royal estates, including Schönbrunn, became the property of the state in 1919. The Palace Captainship that had existed since 1700 was transformed in 1921 into a bureau of the Federal Ministry of Trade and Transport. Regardless of the fact that the emperor had left Schönbrunn, some annexes continued to be inhabited by the former palace staff. However, the way the use of other parts of the former residence was managed was very controversial. Over the course of the 1920s, a motley range of individuals, societies, and organizations moved into and out of Schönbrunn, e.g., the war-wounded, the Social Democratic association Friends of Children (*Kinderfreunde*), a bourgeois private school, the Boy Scouts, and a

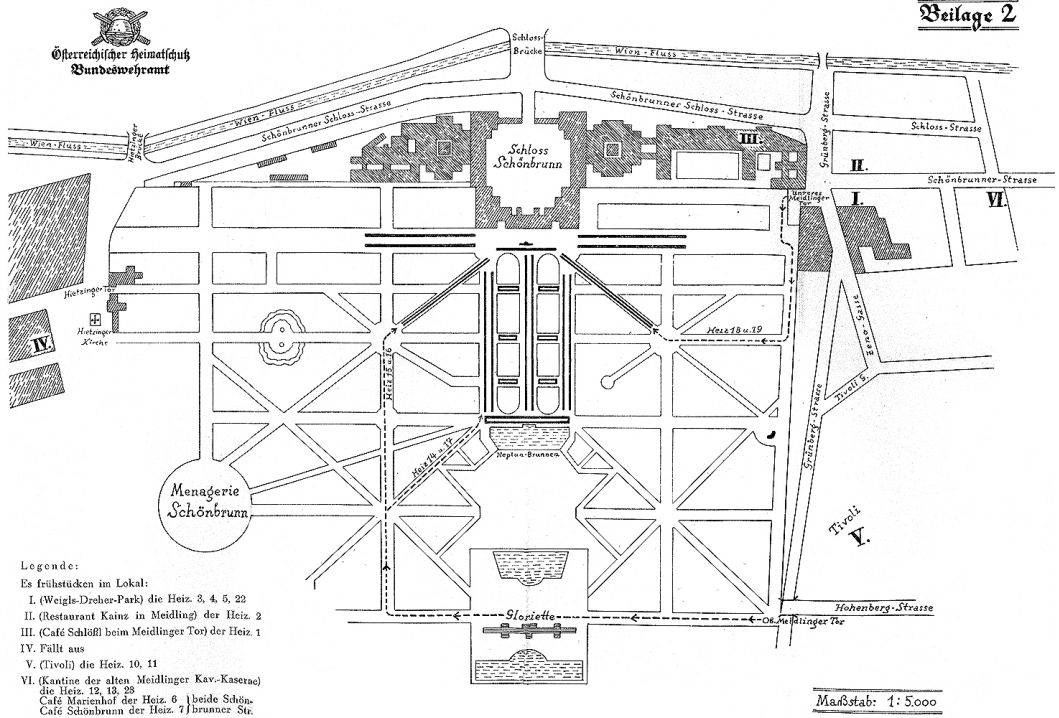

Legende:
 Es frühstücken im Lokal:
 I. (Weigls-Dreher-Park) die Heiz. 3, 4, 5, 22
 II. (Restaurant Kainz in Meidling) der Heiz. 2
 III. (Café Schöll beim Meidlinger Tor) der Heiz. 1
 IV. Fällt aus
 V. (Tivoli) die Heiz. 10, 11
 VI. (Kantine der alten Meidlinger Kav.-Kaserne) die Heiz. 12, 13, 23
 Café Marrenhof der Heiz. 6 | beide Schönbrunn der Heiz. 7 | brunner Str.

Fig. 54: Map showing the marching routes to the assembly area of the “Turks Deliverance Celebration” by the Austrian Homeland Protection in the gardens of Schönbrunn Palace in Vienna on May 14, 1933, printed in *Weisungen für die Türkenbefreiungs-Gedenkfeier am 14. Mai 1933 in Wien*, Vienna: Österreichischer Heimatschutzverband 1933, appendix 2. Source: Vienna University Library, I-514990.

youth hostel. In addition, not long after the war had ended, the Habsburgs’ private and state apartments were converted into a museum. However, the number of visitors to the palace was much lower than to the menagerie in the gardens, which dates from 1751 and was renamed Schönbrunn Zoo (*Schönbrunner Tiergarten*) in 1926.²²⁸

The “Turks Deliverance Celebration” on May 14, 1933, thus took place on a plot of land that had belonged to the House of Habsburg for 350 years, from 1569 to 1919, and had since been used by the public for diverse purposes. The imperial residence, originally planned by the important Baroque architect Fischer von Erlach, had been created shortly after and in living memory of that same “deliverance from the Turks” in September 1683 whose 250th anniversary was now to be celebrated (a couple of months early) by the Austrian

Homeland Protection. Yet the palace building only played a role in the event to the extent that it provided the backdrop for the rally being held in its garden, for which Home Guard members had traveled from all over Austria in special “Homeland Protection chartered trains” (*Heimatschutz-Sonderzüge*). The logistics for the celebration were regulated by instructions, which had been published shortly beforehand by the federal leadership of the Homeland Protection League.²²⁹ In addition to the train timetables, the brochure contained directions about the dress code (green Home Guard jacket), hygiene (tallow feet), provisions (cocoa and bread), and some rules of conduct (such as the advice that smoking was prohibited during the field Mass). A vital part of these instructions was the plans and information about the “march to the assembly area,” which explained in detail how the occupants of the twenty-three chartered trains should march to the palace gardens and then to the Great Parterre, i.e., the area between the palace and the Schönbrunn hill.

Fig. 54, p. 138

These maps demonstrate the **marching routes** from the east through the Meidling gates into the gardens and the arrangement of the troops on the area in front of the palace. All routes led to the palace’s south terrace, where the altar for the field Mass and the speaker’s podium would be set up. This centralized arrangement is no accident but rather precisely mimics the architecture of the palace gardens, which from every angle direct one’s gaze to the center, the imperial residence. Conversely, the emperor or empress could go out onto the terrace from the ballroom and enjoy the prospect of the garden kingdom that they had created from a central position. What then could **Ernst Rüdiger Starhemberg**, who took up this sovereign position on May 14, 1933, see from there? There is a **photograph** of the “Turks Deliverance Celebration” that was taken during Starhemberg’s speech. The federal leader of the Homeland Protection and initiator of the rally stands on the podium with his arm raised in greeting; the photographer must have been standing behind him on

III.1.1

Fig. 40, p. 111

229 See Arthur Karg-Bebenburg: *Weisungen für die Türkenbefreiungs-Gedenkfeier am 14. Mai 1933 in Wien*, Vienna: Österreichischer Heimatschutzverband 1933.

his left, aiming his lens above the audience so that not only is the speaker in front of the microphones visible, but also the mass of listeners.

Fig. 55, p. 141 The central perspective of this picture shows thousands of Home Guard men positioned according to plan in the main axis of the garden. In the Great Parterre—the gardens’ ballroom, as it were, that guaranteed an unobstructed view of the residence and in this specific case of the leader on the balcony—only the planted areas were unoccupied, in compliance with the Palace Captainship’s stipulation that the flower beds remain unharmed. The level assembly area is fenced off to the sides by tall walls of hedges and to the back by the **Neptune Fountain**, which was completed in 1780 and whose form—ascending on both sides to the tallest point in the center—is emphasized by a row of trees. It is not clear in the photo that the god of the sea, leaning on his trident, is frozen in a similar pose to that of Starhemberg in the picture. With his raised arm, he stands over his followers, the Tritons controlling the seahorses, and has the power to churn up or calm the waves.

Fig. 55, p. 141 Behind the fountain the Schönbrunn hill towers with its zigzag paths, where civilians could witness the rally.²³⁰ The composition culminates in the **Gloriette** on the crest of the hill, which had already been conceived as a belvedere in Fischer’s **design from 1696** but was only constructed under Maria Theresa in 1775. On the one hand, this backdrop is an impactful conclusion to the view of the garden as seen from the palace, and on the other it is an observation platform that makes it possible to overlook not only the (former) summer residence but also the city (and former imperial seat). On the central section of the arcade, an eagle sits atop a globe, holding a laurel wreath as a symbol of victory in its beak. That the Gloriette is interpreted in the literature as a monument to the “just war,”²³¹ is thematically quite fitting for the “Turks Deliverance Celebration,” which according to Starhemberg was intended to commemorate the “world-historical fact that Christianity, German customs and culture, and thus also the

230 See Karg-Bebenburg: *Weisungen für die Türkenbefreiungs-Gedenkfeier am 14. Mai 1933 in Wien*, p. 13.

231 See, for example, Hajós: *Die Schönbrunner Schlossgärten*, p. 97.



Fig. 55: Ludwig Rohbock and Carl Rohrich: *The Neptune Basin in the Imperial Palace Gardens of Schönbrunn in Vienna* (1873), in the background the Gloriette. Source: Schloss Schönbrunn Kultur- und Betriebsges.m.b.H., SKB 000168.

then German Reich were rescued from Eastern barbarism 250 years ago on Austrian soil.”²³²

The photographic images of the rally make clear the distinctive position of Schönbrunn’s garden between the palace and the hill, which does not provide a seemingly infinite view, as conceived by André Le Nôtre, the famous landscape architect of Louis XIV, in the parterre of Versailles, but rather creates and shapes a limited space.²³³ In another regard, however, Schönbrunn implements the principles of the French Baroque garden systematically, namely in the complex of avenues, which was intended to function like an urban transport network.²³⁴ At the center of this miniature city, as mentioned above, is the garden-side terrace of the palace, from which five monumental “streets” radiate out. During the “Turks Deliverance Celebration,” they were all occupied by Home Guard troops. In the **photo** taken during Starhemberg’s speech, only the north-south “main road” is visible, the Great Parterre; however, select units and honorary guests were also placed in the so-called

Fig. 40, p. 111

232 Ernst Rüdiger Starhemberg: “Schlusswort,” in: Arthur Karg-Bebenburg: *Weisungen für die Türkenbefreiungs-Gedenkfeier am 14. Mai 1933 in Wien*, Vienna: Österreichischer Heimatschutzverband 1933, pp. 14–15, here p. 14 [our trans.].

233 See Richard Kurdiovsky: *Die Gärten von Schönbrunn. Ein Spaziergang durch einen der bedeutendsten Barockgärten Europas*, St. Pölten: Residenz 2005, pp. 24–28.

234 See [Antoine Joseph Dézallier D’Argenville:] *La théorie et la pratique du jardinage*, Paris: Jean Mariette 1709, pp. 39–46.

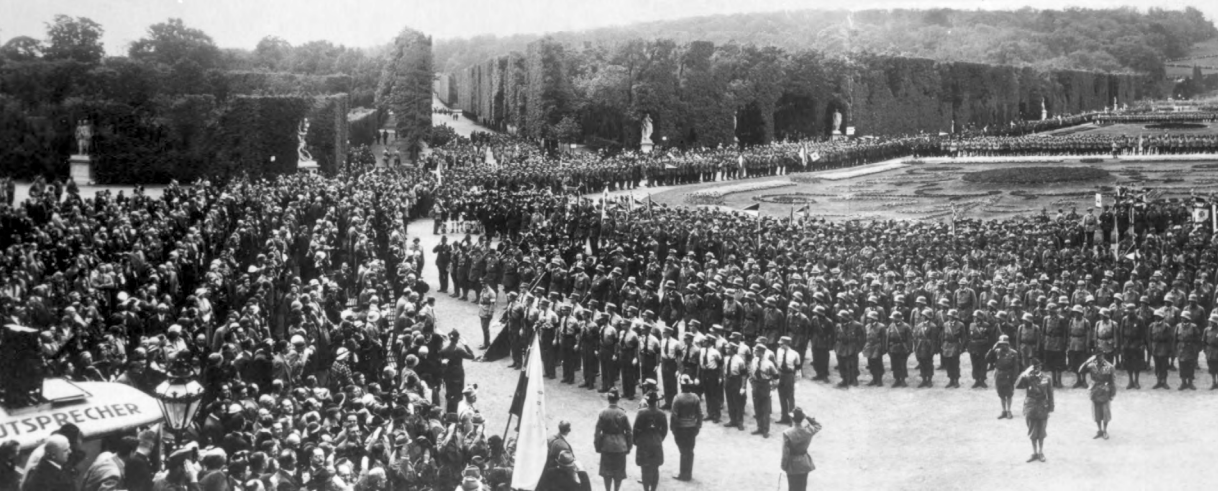

Fig. 56, p. 143

Light Avenue (*Lichte Allee*), which runs laterally to the east and west immediately in front of the palace. Furthermore, the occupants of the chartered trains numbers fifteen and sixteen, as well as eighteen and nineteen, stood in a column along the two large diagonal avenues.²³⁵ If the camera, positioned behind Starhemberg, were to pan left and right, one would see the Obelisk Fountain at the end of the southeast avenue and the pavilion of the menagerie at the end of the southwest avenue.

Fig. 56, p. 143

These structures are worth mentioning because they add meaning to the functions of Schönbrunn's gardens as described above. Constructed in 1777, the obelisk serves as a *point de vue* in the eponymous **diagonal avenue**, which extends from the castle terrace to the garden's easternmost limits. Brought to Europe from Egypt by the Romans, the rectangular, tapered column had symbolized the life-giving power of the sun since antiquity, but in the Baroque it also came to represent the constancy of a leader, which in the case of the Schönbrunn obelisk is emphasized by the four turtles that carry it. The top is crowned with a golden eagle, which mediates between heaven and earth like the sovereign.

Fig. 57, p. 144

The **Obelisk Fountain** is connected thematically to the neighboring Roman Ruin, which was completed one year later. Likewise constructed as the focal point of an avenue, this garden structure shows

235 See Karg-Bebenburg: *Weisungen für die Türkenbefreiungs-Gedenkfeier am 14. Mai 1933 in Wien*, p. 9.

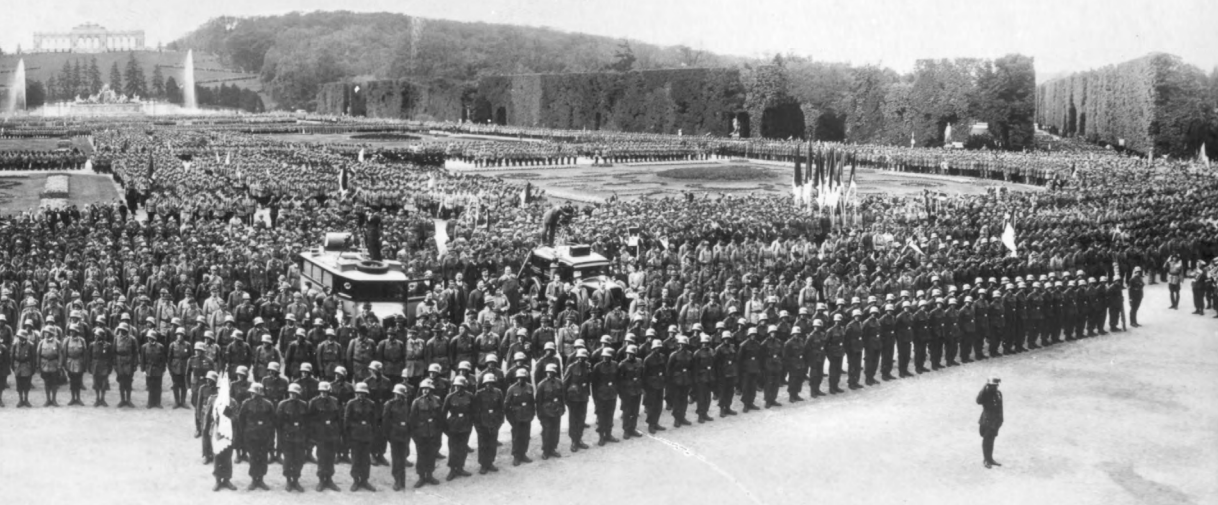

Fig. 56: Panoramic photograph of the “Turks Deliverance Celebration” by the Austrian Homeland Protection in the gardens of Schönbrunn Palace in Vienna on May 14, 1933: in the lower part the Light Avenue and in the center the Great Parterre with the Neptune Fountain and the Gloriette in the background; diagonally left the Obelisk Avenue and diagonally right the Zoo Avenue; on the very left a podium or truck marked “[Laut]sprecher” (“[loud]speaker”); between the Home Guard men the recording vans of the Selenophon Licht- und Tonbild GmbH (on the left) and of Fox Movietone News (or of a freelance cameraman). Source: Austrian National Library, Pk 2839.

an ancient building, which is half sunken in the ground and which, according to its original name, was intended to represent Carthage, the North African city destroyed by the Romans in the Punic Wars. Therefore, the Schönbrunn ruin alludes to the vanquished enemies of the House of Habsburg, whose claim to eternal reign, dating back to the Roman Empire, is not only embodied in the obelisk and the Gloriette but is also the conceptual foundation of the statues around the Great Parterre.²³⁶

Fig. 56, p. 143

Fig. 58, p. 144

The western counterpart to the obelisk is the pavilion in the zoo at the end of the **diagonal avenue** on the Hietzing side, which can also be seen from the palace terrace. Game animals had been kept in this area since Emperor Maximilian II had acquired the land. The **menagerie** was created in the mid-eighteenth century on the initiative of Francis I Stephen.

236 On the Obelisk Fountain and the Roman Ruin in Schönbrunn, see Hajós: *Die Schönbrunner Schlossgärten*, pp. 33–36 and 163–170, and Kurdiovsky: *Die Gärten von Schönbrunn*, pp. 34–35 and 103–109.

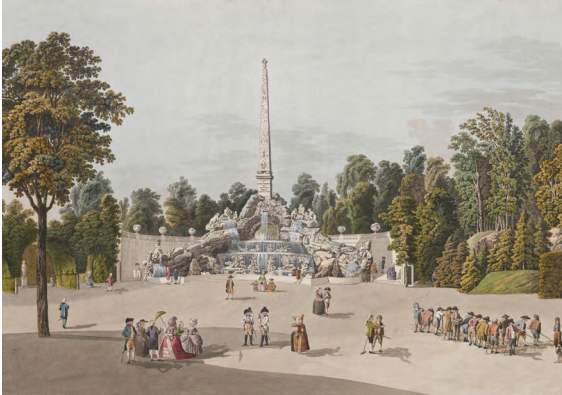

Fig. 57: Laurenz Janscha and Johann Ziegler: *The Waterfall with the Obelisk in the Imperial-Royal Gardens of Schönbrunn* (1785). Source: Austrian National Library, Z85041107.

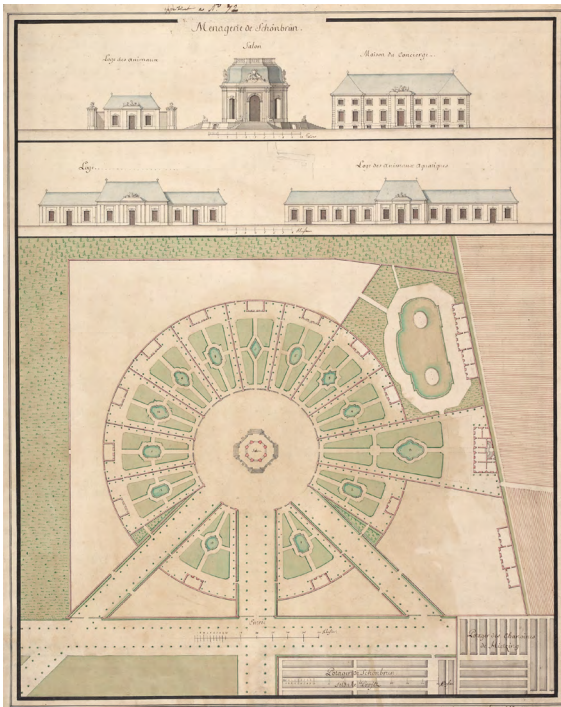

Fig. 58: Layout of the menagerie in Schönbrunn by Jean-Nicolas Jadot (1755). Source: Albertina (Vienna), AZ5497.

His architect from Lorraine, Jean-Nicolas Jadot, designed an octagonal pavilion on a round square from which sixteen axes radiated out: three avenues, an administration building, and twelve animal enclosures, which were designed as small Baroque gardens. It was only possible to look into them from the center, where the imperial couple would breakfast in the pavilion and observe the animals in the panorama, which had been brought to the imperial residence from all over the

world. Moreover, below the menagerie, on the west edge of the palace garden, Francis Stephen had a botanical garden laid out, which was named after the homeland of its gardeners. Partly procured during expeditions, the plant populations of the Dutch Garden were arranged in square sections according to the taxonomy of the Swedish botanist Carl von Linné, the so-called Linnaean system. In the Baroque palace grounds of Schönbrunn, whether in the parterres and avenues or in the menagerie and the botanical garden, nature was controlled rationally, which meant first and foremost geometrically.²³⁷

237 On the menagerie and the Dutch Garden in Schönbrunn, see Hajós: *Die Schönbrunner Schlossgärten*, pp. 183–185 and 202–204, and Kurdiovsky: *Die Gärten von Schönbrunn*, pp. 116–117 and 126–130.

1.4 Theater: Fascism as Tragedy



place Burgtheater
 moment Staging of *Hundred Days*
 space N 48.210275° | E 16.361378°
 time 1932 a 132 d 19 h 30 min p. Chr.

- II.10 In the evening before the “**Turks Deliverance Celebration**” (*Türkenbefreiungsfeier*), which took place on Sunday, May 14, 1933, in the **gardens of Schönbrunn Palace**, the drama *Hundert Tage* (*Hundred Days*) was performed at Vienna’s Burgtheater.²³⁸ At a cursory glance, there seems to be no relation between the political rally and the theatrical production. A closer examination of the two events, however, reveals a dense web of personal and thematic connections, mainly linked by **Benito Mussolini**, the founder of Fascism who had been Italy’s prime minister since 1922. Mussolini was not only the financial backer of the “Turks Deliverance Celebration” and a patron of its initiator, **Ernst Rüdiger Starhemberg**,²³⁹ but also the coauthor of the play, which had premiered in Rome in 1930 under the title *Campo di maggio* and covers Napoleon’s rule during the Hundred Days between his exile on the islands of first Elba and then Saint Helena.²⁴⁰
- Fig. 65, p. 161
- III.1.1

The German author Emil Ludwig, who achieved international fame in the 1920s with historical biographies, was told by Mussolini that his book on Napoleon had inspired him to

- 238 See “Theater,” in: *Neue Freie Presse* (Vienna), May 13, 1933 (morning edition), p. 16.
- 239 See Ernst Rüdiger Starhemberg: *Die Erinnerungen*, Vienna/Munich: Amalthea 1991, p. 142, and Lothar Höbelt: *Die Heimwehren und die österreichische Politik 1927–1936. Vom politischen “Kettenhund” zum “Austro-Fascismus”?*, Graz: Ares 2016, pp. 271–272.
- 240 The expression “Hundred Days” originally meant the (in fact 110-day) absence of King Louis XVIII from Paris, but today it usually refers to the period between Napoleon’s return from Elba and his banishment to Saint Helena. See Volker Hunecke: *Napoleons Rückkehr. Die letzten Hundert Tage – Elba, Waterloo, St. Helena*, Stuttgart: Klett-Cotta 2015, p. 9.

sketch out a drama, which he then had Giovacchino Forzano finalize.²⁴¹ Forzano, an established dramatist and librettist in Italy at the time, corroborated this portrayal of events and later published the following letter:

Dear Forzano,

I am sending you the paper, crumpled as it is from lying on my desk for so long, which contains the title and the four acts inspired by reading Ludwig's Napoleon, which I told you about. I have contemplated it, but only you could write it, since only you possess the eminent genius required by the theater: that which makes the characters move, makes them speak, which makes things happen. Read the book from the pages that I have marked for you, and you will see that it is possible to create a play full of color, full of life, full of events and protagonists. Give me word occasionally. Congratulations on Carro di Tespi and warm regards.

Mussolini

Rome, July 7, 1929—Anno VII²⁴²

According to the actor Werner Krauss, who played the lead in the Vienna production, the “paper” to which Mussolini refers in his letter to Forzano was in fact “twelve or fourteen letters written in large handwriting, merely declarations by a statesman on what it is actually about.”²⁴³ Forzano transformed these drafts into a tragedy about the fall of Napoleon, though it does not contain the “four acts” outlined by Mussolini, but merely three acts with nine scenes, or rather “pictures.”²⁴⁴

- 241 See Emil Ludwig: *Mussolinis Gespräche mit Emil Ludwig*, Berlin: Zsolnay 1932, p. 212. Mussolini means Emil Ludwig's biography *Napoleon* (Berlin: Rowohlt 1925), not his drama of the same name (Berlin: Cassirer 1906), which was rather unsuccessful.
- 242 Cit. after Giovacchino Forzano: “La mia collaborazione teatrale con Benito Mussolini,” in: *Mussolini autore drammatico*, Florence: Barbèra 1954, pp. V–XLIII, here p. XXIII [our trans., emphasis in original].
- 243 Werner Krauss: *Das Schauspiel meines Lebens*, Stuttgart: Henry Goverts 1958, p. 157 [our trans.].
- 244 According to Forzano, Mussolini himself had queried the fourth act on Napoleon's departure to Saint Helena, see Géza Herczeg: “Mussolini als Bühnendichter,” in: *Burgtheater Offizielles Programm* [of the play *Hundert Tage*], Vienna: Weiner [1933], pp. 7–16, here p. 11, source: Theatermuseum (Vienna), program archive. →

In Italy, Mussolini was cited as coauthor neither at the play's premiere nor in its print edition.²⁴⁵ He only allowed his name to be used for the performances abroad: in Budapest and Paris in 1931, in Weimar and London in 1932, in Vienna in 1933, and in Berlin in 1934.²⁴⁶ On the cover of the German translation by Géza Herczeg, Mussolini is even named first as the lead author, going against alphabetical order.²⁴⁷

Whereas in Italy Mussolini presumably wanted to wait and see whether the play would prove popular, abroad—above all in Germany and Austria—his name was vital to its enormous box-office success. After the German premiere on January 30, 1932, at the Nationaltheater in Weimar, attended by Adolf Hitler,²⁴⁸ *Hundred Days* was performed at the Burgtheater in Vienna in spring 1933. The **Vienna premiere** on April 22, 1933, developed into a major diplomatic event, at which Education Minister Anton Rintelen, Italian Ambassador Gabriele Preziosi, and Ernst Rüdiger Starhemberg, among others, were

Fig. 24, p. 65

- On the cooperation between Mussolini and Forzano, yielding apart from *Campo di maggio* the dramas *Villafranca* (1932) and *Cesare* (1939), see Stanley V. Longman: "Mussolini and the Theatre," in: *Quarterly Journal of Speech*, 60/2 (1974), pp. 212–224, here pp. 221–224, and Toni Bernhart: "Benito Mussolini als Schriftsteller und seine Übersetzungen ins Deutsche," in: Andrea Albrecht, Lutz Danneberg, Simone De Angelis (eds.): *Die akademische "Achse Rom-Berlin"? Der wissenschaftlich-kulturelle Austausch zwischen Italien und Deutschland 1920 bis 1945*, Berlin: Walter de Gruyter 2017, pp. 345–399, here pp. 348–351.
- 245 See Giovacchino Forzano: *Campo di maggio. Dramma in tre atti*, Florence: Barbèra 1931.
- 246 See Forzano: "La mia collaborazione teatrale con Benito Mussolini," p. XXIX, and Herczeg: "Mussolini als Bühnendichter," p. 7. For the foreign productions, the title was altered to *Hundred Days: Száz nap* (National Theater, Budapest, June 4, 1931), *Les cents jours* (Théâtre de l'Ambigu-Comique, Paris, November 9, 1931), *Hundred Days* (New Theatre, London, April 14, 1932).
- 247 See Benito Mussolini and Giovacchino Forzano: *Hundert Tage (Campo di maggio). Drei Akte (acht Bilder). Für die deutsche Bühne bearbeitet von Géza Herczeg*, Berlin: Marton 1932 [Italian 1931]; Benito Mussolini and Giovacchino Forzano: *Hundert Tage (Campo di maggio). Drei Akte in neun Bildern. Autorisierte Übersetzung von Géza Herczeg*, Vienna: Zsolnay 1933 [Italian 1931]. The following short references to *Hundert Tage* in this chapter relate to the German edition from 1933.
- 248 See Kerstin Decker: *Die Schwester. Das Leben der Elisabeth Förster-Nietzsche*, Berlin: Berlin Verlag 2016, pp. 591–595.

present.²⁴⁹ After the second act, Rintelen sent a congratulatory telegram to Mussolini, and the third act was broadcast internationally on the radio.²⁵⁰ The launch party, to which not only the actors and politicians but also the translator Géza Herczeg were invited, was hosted by the Italian embassy in Vienna.²⁵¹ The play was performed at the Burgtheater a further thirty-five times before late June 1933, including nineteen times in May, and seen by some 54,000 theatergoers.²⁵² In Vienna *Hundred Days* remained in the repertoire until 1937; in Berlin the drama was performed at the Staatstheater in 1934, likewise with Werner Krauss as Napoleon, who also played the lead in the German screen adaptation in 1935.²⁵³

The play's success arrived at a very opportune moment at the Burgtheater, though this was no accident. Founded in the eighteenth century, the traditional Viennese stage had run into serious financial trouble, to the extent that in the early 1930s there was talk of a "Burgtheater crisis" and even the threat of its closure. In order to gain control of the situation, the Ministry of Education, which was responsible for the federal theaters, searched for a new manager for the Burgtheater who would have not only artistic skill but also financial experience. The man they chose was Hermann Röbbeling, who had successfully run the Schauspielhaus and the Thalia Theater in Hamburg as private companies. Röbbeling assumed the management of the Burgtheater in December 1931 and soon lived up to his reputation for restoring theaters to profitability: he invited

249 See "Galaabend im Burgtheater," in: *Neues Wiener Journal* (Vienna), April 23, 1933, p. 7.

250 See "Telegramm des Unterrichtsministers Dr. Rintelen an den Duce," in: *Neues Wiener Journal* (Vienna), April 23, 1933, p. 7; "Radio-Wochenprogramm vom 22. bis 30. April," in: *Neue Freie Presse* (Vienna), April 22, 1933 (evening edition), p. 4.

251 See "Empfangsabend auf der italienischen Gesandtschaft," in: *Neues Wiener Journal* (Vienna), April 23, 1933, p. 7.

252 See Margret Dietrich: "Burgtheaterpublikum und Öffentlichkeit in der Ersten Republik," in: Margret Dietrich (ed.): *Das Burgtheater und sein Publikum*, vol. 1, Vienna: Österreichische Akademie der Wissenschaften 1976, pp. 479–707, here pp. 684 and 692.

253 In 1935, a German and an Italian screen adaptation of the play was released, entitled *Hundert Tage* (direction: Franz Wenzler, Napoleon: Werner Krauss) and *Campo di maggio* (direction: Giovacchino Forzano, Napoleon: Corrado Racca).

the press to dress rehearsals, had performances broadcast live on the radio, negotiated reduced federal rail tickets for theatergoers, expanded the season ticket system, and introduced weekly performances for school students. However, this financial success was accompanied by vehement criticism of the alleged commercialization of the Burgtheater. Ideologically, Röbbeling was guided primarily by the conservative and increasingly authoritarian notions of his most important financier, the Austrian federal government.²⁵⁴

A good example of the artistic and economic orientation of the Burgtheater under Hermann Röbbeling is the festival cycle “Voices of the Peoples in Drama” (*Stimmen der Völker im Drama*), which he retrospectively declared his “greatest success.”²⁵⁵ At the very beginning of his tenure, in February 1932, he had given a talk at the Österreichische Völkerbundliga (Austrian Alliance of the League of Nations) emphasizing that theater furthered the association of nations: he argued that plays from antiquity to the present day made one aware that though people may have cultural differences, at heart they are all connected.²⁵⁶ In the *Almanach der österreichischen Bundestheater* for the 1932/33 season, Röbbeling then explained the meaning of this particular series of works at the Burgtheater: “a representative piece of literature is intended to bring to the stage a *specific national character* and create understanding for another type of people and a peculiar artistic expression.”²⁵⁷ Having launched in October 1932 with Franz Grillparzer’s

- 254 See Sophia Totzeva: “Der Festspielzyklus ‘Stimmen der Völker im Drama’ (1932–1938). Übersetzungs- und Theaterpraxis im Spannungsfeld von Politik und Ideologie,” in: *Maske und Kothurn*, 42/2–4 (1996), pp. 77–103, here pp. 77–81, and Johann Hüttner: “Die Staatstheater in den dreissiger Jahren. Kunst als Politik – Politik in der Kunst,” in: Hilde Haider-Pregler and Beate Reiterer (eds.): *Verspielte Zeit. Österreichisches Theater der dreissiger Jahre*, Vienna: Picus 1997, pp. 60–76, here pp. 63–64.
- 255 Cit. after an interview in Tekla Kulczicky de Wolczko: *Hermann Röbbeling und das Burgtheater*, University of Vienna: PhD diss. 1950, p. 130 [our trans.].
- 256 See Hermann Röbbeling: *Das Theater als völkerverbindender Faktor*, Vienna: Weiner 1932.
- 257 Cit. after “Der Spielplan des Burgtheaters,” in: *Almanach der österreichischen Bundestheater für das Spieljahr 1932/33*, Vienna: Wirtschafts-Zeitungs-Verlags-Ges.m.b.H. 1933, pp. 17–22, here p. 19 [our trans., emphasis in original].

“Austrian tragedy” *Ein Bruderzwist in Habsburg (Fraternal Strife among the Habsburgs)*, the cycle was intended to continue with a series of fifteen foreign works,²⁵⁸ but by 1938 only twelve productions had been realized. The play that was originally planned for Italy was *La Gioconda* by Gabriele D’Annunzio, but the Italian “national character” was ultimately represented by two other dramas, which were not initially conceived as part of the cycle but were retrospectively ascribed to it, namely *Campo di maggio* by Forzano and Mussolini and Carlo Goldoni’s comedy *Il bugiardo*.²⁵⁹

Röbbling’s management and his cycle “Voices of the Peoples in Drama” unfolded against a backdrop of a public debate about the Austrian “national theater,” which dated back to the eighteenth century and underwent a marked resurgence in the First Republic. The question when exactly the Burgtheater itself was founded cannot be answered with just one year.²⁶⁰ Emperor **Leopold I** had already opened a large court theater in Vienna’s Hofburg Palace around 1700, where later the Redoutensäle ballrooms were constructed. Subsequently, Maria Theresa had the vacant **Hofballhaus**, where court tennis had been played, on (what is now) Michaelerplatz converted into the Theater nächst der Burg (Theater by the Palace) from the 1740s and run by leaseholders. Predominantly French dramas and Italian operas were performed there, in accordance with the language customs of the nobility, while in the popular Theater nächst dem Kärntnerthor comedies were improvised in German or Viennese dialect, plays in which the character of the Hanswurst buffoon always made an appearance.

Fig. 78, p. 196

Fig. 61, p. 153

258 See Hermann Röbbling: “Stimmen der Völker im Drama,” in: *Almanach der österreichischen Bundestheater für das Spieljahr 1932/33*, Vienna: Wirtschafts-Zeitungs-Verlags-Ges.m.b.H. 1933, pp. 22–24, here p. 24.

259 See Totzeva: “Der Festspielzyklus ‘Stimmen der Völker im Drama’ (1932–1938),” pp. 82–84.

260 On the following historical remarks, see Franz Hadamowsky: “Die Schauspielfreiheit, die ‘Erhebung des Burgtheaters zum Hoftheater’ und seine ‘Begründung als Nationaltheater’ im Jahr 1776,” in: *Maske und Kothurn*, 22/1–2 (1976), pp. 5–19, and Andrea Sommer-Mathis: “Theater und Fest,” in: Hellmut Lorenz and Anna Mader-Kratky (eds.): *Die Wiener Hofburg 1705–1835. Die kaiserliche Residenz vom Barock bis zum Klassizismus*, Vienna: Österreichische Akademie der Wissenschaften 2016, pp. 457–486.



Fig. 59: The new building of the Burgtheater in Vienna, which opened on the Ringstrasse in 1888, photographed around 1930. Source: Austrian National Library, 140.791 B.



Fig. 60: Stage and auditorium of the Burgtheater in Vienna, photographed around 1930. Source: Austrian National Library, L 5.871D.

Under the aegis of Joseph von Sonnenfels, the views of literary figures who advocated a German “national theater” like Johann Christoph Gottsched and Gotthold Ephraim Lessing spread through the Viennese bourgeoisie from the 1760s. However, this expression certainly did not imply popularity (*Volkstümlichkeit*) in the sense of the Theater nächst dem Kärntnerthor, but rather a “regular” stage with unvarying, High German, moralizing texts. Maria Theresa’s son, Emperor Joseph II, who was not averse to the ideas of the Enlightenment, ultimately decreed in a letter from March 23, 1776, that the Theater nächst der Burg, which his mother had had constructed, be run in future as “the German National Theater.”²⁶¹ Nevertheless, the purely German-language repertoire barely lasted two months, and even the title National Theater was soon changed to Die Kaiserlich-

261 Letter by Joseph II to Prince Khevenhüller from March 23, 1776, in the Austrian State Archives (ÖStA/HHStA, KA Handbilleter, Akten 1) [our trans.].



Fig. 61: Colorized drawing of the return from the so-called “ladies’ carousel” (*Damenkarussell*) on January 2, 1743, a courtly tournament in which equestriennes, among them queen Maria Theresa, tried to spear wooden heads of Moors and Turks. To the right of the Winter Riding School, in front of the unfinished Michaelertrakt of the Vienna Hofburg, the Hofballhaus is located, a ballroom building that was rebuilt into the Theater nächst der Burg from the 1740s onward. Source: Wien Museum, 31669.

Fig. 62, p. 154

Fig. 59 &
Fig. 60, p. 152

Königlichen National-Hofschauspieler (The Imperial-Royal National Court Players), until in the nineteenth century the name **K.K. Hofburgtheater** (Imperial-Royal Hofburg Palace Theater) became established, which was also adopted for the **new building** on Vienna’s Ringstrasse when it was opened in 1888.

In 1934 Rudolph Lothar published an updated and augmented edition of his Burgtheater history from 1899. Following a foreword by the then Education Minister Kurt Schuschnigg, who played a major role in the establishment of the authoritarian “corporative state” (*Ständestaat*), the journalist and dramatist analyzed the question of the national theater in his introduction and emphasized that in artistic matters Austria actually meant Vienna. The Vienna court—unlike that in Paris, for example—had, however, never been “national,” he continued, but rather a colorful medley of European noble families. “The truly national art of Vienna and thus Austria lay somewhere else entirely,” Lothar explained, “it could be found on the



Fig. 62: The Michaelerplatz in Vienna with the Old Burgtheater (on the right), photographed in 1885. Source: Austrian National Library, Kor 73/1.

squares of the inner city and the suburbs, in shacks and sports halls and sprouted its funny flowers in the improvised farce and in the extemporized burlesque.” The Hofburgtheater had emerged as a “protest against this elemental art”; it had wanted to “dethrone and kill the national Hanswurst.”²⁶² The most important task of Hermann Röbbeling, the new manager, was to run the Burgtheater as the truly “national theater of Austria,” it says at the end of the book, and to cultivate Austrian drama as the “strongest expression of down-to-earth patriotism.”²⁶³

Five years later, when the “corporative state” was already history and the “Eastern March” (*Ostmark*) had become part of the Greater German Reich, another book on the Burgtheater was published, this time by the German philologist Heinz Kindermann, who was promoted to head of the newly founded Department of Theater Studies at the University of Vienna in 1943. While Lothar had wanted to derive Austrian national theater from the folk art of Vienna, Kindermann immediately stressed in his foreword that his subtitle “Legacy and Mission of a National Theater” (*Erbe und Sendung eines Nationaltheaters*) did not imply a “merely Viennese or merely German-Austrian affair,” but rather a Greater German cultural institution.²⁶⁴ He elaborated that the Burgtheater’s selection of works first and

262 Rudolph Lothar: *Das Wiener Burgtheater. Ein Wahrzeichen österreichischer Kunst und Kultur*, Vienna: Augartenverlag 1934, pp. 11–12 [our trans.].

263 Lothar: *Das Wiener Burgtheater*, pp. 521–522 [our trans.].

264 Heinz Kindermann: *Das Burgtheater. Erbe und Sendung eines Nationaltheaters*, Vienna: Adolf Luser 1939, p. 5 [our trans.].

foremost had to revolve around the “bountiful dramatic legacy of the Germans,” while also incorporating the most important pieces from foreign nations in the interests of a “fruitful encounter with their otherness,” though “Shakespeare, whom we perceive to be almost German,” was excluded from this strict selection. “As today we think in racially definable national units,” Kindermann wrote, “our choice of the drama representing the individual peoples of world literature (in Goethe’s sense) will surely look different from that offered by the liberal viewpoint, that is, also different from how Röbbeling’s ‘Voices of the Peoples in Drama’ presented these nations.”²⁶⁵

Röbbeling’s declarations that the cycle was aimed at bringing peoples together may at times have been at odds with the plays that were actually performed, as can be demonstrated by the example of *Hundred Days*. However, the selection of works, in which Grillparzer’s *Ein Bruderzwist in Habsburg* was followed in February 1933 by the drama *Florian Geyer* by Gerhart Hauptmann, shows that nations were understood to mean internationally recognized states, in this case Austria and Germany, and not “racially definable national units”²⁶⁶ in the National Socialist sense.²⁶⁷ In his conversations with Emil Ludwig, Mussolini went even further and said that nations were the result of neither systems of government nor biological or linguistic communities. “Race” was “not a reality” but “an illusion of the spirit, a feeling,” which one could choose and develop.²⁶⁸ On this question of what constitutes a nation, there is a similar answer in Mussolini’s essay *La dottrina del fascismo* from 1932, which was translated into German and English, among other languages, in the years that followed:

265 Kindermann: *Das Burgtheater*, pp. 211 and 214 [our trans.].

266 Kindermann: *Das Burgtheater*, p. 214 [our trans.].

267 See Totzeva: “Der Festspielzyklus ‘Stimmen der Völker im Drama’ (1932–1938),” pp. 83, 91, 95.

268 Ludwig: *Mussolinis Gespräche mit Emil Ludwig*, pp. 74–77 and 228 [our trans.]. See, however, the historical studies by Wolfgang Schieder, who identifies these conversations as the “political art of disguise” and points to Mussolini’s increasingly racist and antisemitic policy, in: *Faschistische Diktaturen. Studien zu Italien und Deutschland*, Göttingen: Wallstein 2008, pp. 46–48 [our trans.].

*Not a race, nor a geographically defined region, but a people, historically perpetuating itself; a multitude unified by an idea and imbued with the will to live, the will to power, self-consciousness, personality.*²⁶⁹

Fig. 63, p. 157

Consequently, for Mussolini, a nation is neither a biologically definable people nor a group of individuals who merely speak the same language or live on a delimited territory. Rather, the citizens of the Fascist state are united in the “conscious membership of a spiritual society,”²⁷⁰ which has genuine “personality,” namely in the form of the *Duce*, who personally embodies and exemplifies Fascism. This superhuman leader adopts a literally *sovereign* position: he overarches the nation like Thomas Hobbes’s *Leviathan* and represents the collective will of his subordinate people. However, in contrast to the monarchical, the Fascist sovereign possesses no dynastic legitimacy. That means that he is not respected because of his noble birth but has to create his own heroic genealogy. Coming from a lower-middle-class family, Mussolini therefore attempted to portray himself as the spiritual descendent of the Roman emperors, while also gladly referring to the Corsican social climber who had crowned himself the “Emperor of the French” in the early nineteenth century.

Napoleon is certainly described as an exemplary self-made man in Emil Ludwig’s historical biography²⁷¹ that inspired the drama *Campo di maggio*. Yet entirely contrary to this account of a democratic hero, Mussolini blames democracy itself for his idol’s downfall, or more precisely, “the course of events on the Champ de Mars in spring 1815.”²⁷² Here he is referring to the so-called Champ de Mai, which Napoleon announced on the march to Paris after having fled his exile on Elba in late February 1815. Reminiscent of the Frankish-Carolingian “Mayfield”

269 Benito Mussolini: “The Doctrine of Fascism” [Italian 1932], in: *Fascism. Doctrine and Institutions*, Rome: Ardita 1935, pp. 5–31, here p. 12. In fact, however, parts of the text were written by the Fascist philosopher Giovanni Gentile, see Schieder: *Faschistische Diktaturen*, p. 42.

270 Mussolini: “The Doctrine of Fascism,” p. 9.

271 See Barbara Besslich: *Der deutsche Napoleon-Mythos. Literatur und Erinnerung 1800–1945*, Darmstadt: WBG 2007, pp. 390–394.

272 Cit. after Ludwig: *Mussolinis Gespräche mit Emil Ludwig*, p. 212 [our trans.].

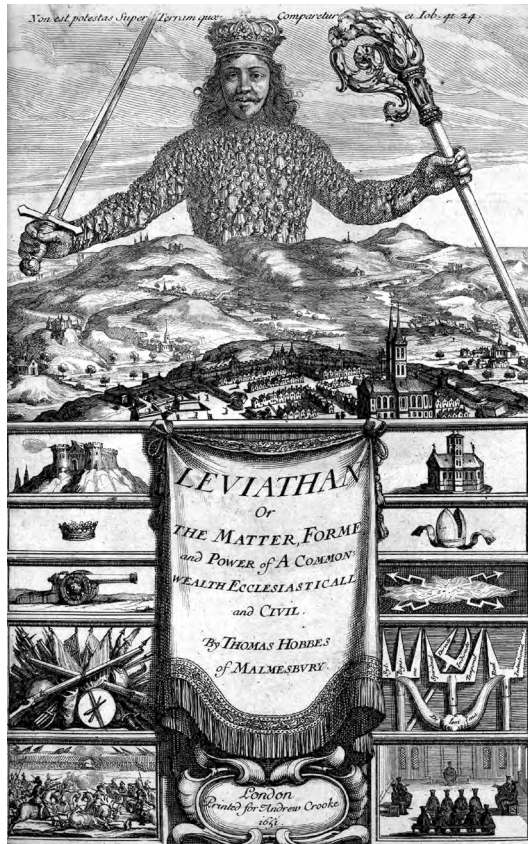

Fig. 63: Abraham Bosse's frontispiece for the book *Leviathan* (London: Andrew Crooke 1651) by Thomas Hobbes. Source: Wikimedia Commons.

Fig. 68, p. 168

Fig. 64, p. 158

(Italian *campo di maggio*), the event was intended to serve on the one hand as a constituent assembly and on the other as a coronation ceremony for the empress. However, as Marie Louise remained in Vienna with their son, Napoleon Francis Bonaparte, and her father, the Austrian Emperor **Francis I**, and as the constitution drafted initially by a commission, then by Benjamin Constant, had already been published in April, the planned National Constituent Assembly dwindled to a mere **ceremonial act**, which was held somewhat belatedly on June 1, 1815, on the Champ de Mars, the Parisian field where the Fête de la Fédération had taken place in 1790.²⁷³

The first act of the play by Forzano and Mussolini is set in the evening and night before the Champ de Mai. In two scenes, the protagonists of the tragedy are introduced: **Joseph Fouché**

273 See Hunecke: *Napoleons Rückkehr*, pp. 101–102.

Fig. 24, p. 65

and Napoleon Bonaparte.

Minister of Police Fouché assures the freshly elected representatives that Napoleon now wanted to rule constitutionally, cajoles first a Count of Orléans, whose duke is talked about as the future monarch, then a lady-in-waiting under Louis XVIII, the now exiled king, and finally bribes the publisher of an opposition newspaper. That night, Napoleon is less concerned by Fouché's intrigues and the impending war than by his son's return. When the emissary finally arrives from Vienna, the emperor believes he can also hear his beloved child in the ante-room but is soon bitterly disappointed. Napoleon had planned to ride on the Champ de Mars in the "Austerlitz uniform" alongside his son in the carriage. Now, as his wife has forsaken him, he appears "dressed up" in the coronation robes before the assembled representatives and soldiers in order to hold an "empty ceremony."²⁷⁴

The second act begins three weeks later: Napoleon's army suffered a catastrophic defeat at Waterloo at the hands of the British and Prussian troops under the command of Field Marshals Wellington and Blücher. After Fouché has induced the ministers and representatives to decide that the emperor has to abdicate, Napoleon arrives in Paris thoroughly exhausted. In his view, he had been betrayed on the battlefield and to "save the fatherland" needed a political mandate from the cabinet and parliament, namely the power to rule temporarily as a military



Fig. 64: Contemporary engraving of Napoleon's oath to the constitution at the Champ de Mai held on the Champ de Mars in Paris on June 1, 1815. Source: Bibliothèque nationale de France, Collection De Vinck 9540.

274 See Mussolini and Forzano: *Hundert Tage*, pp. 11–60, quotes pp. 40 and 43 [our trans.].

dictator. Yet in the name of the representatives, General Lafayette insists on Napoleon's resignation, who had himself become the greatest barrier to peace. Reluctantly, but to prevent a civil war, the emperor abdicates in favor of his son. The representatives' expectations that they would be able to negotiate a ceasefire with the victorious powers are revealed in the third act to be a naïve illusion. Instead, the enemy generals dictate humiliating peace terms to the conquered French: Louis XVIII will be brought back as king, Fouché appointed his prime minister, France subjected to military occupation, and Napoleon exiled to a distant island, probably Saint Helena. The drama ends in Château de Malmaison, where Napoleon bids farewell to his family.²⁷⁵

The plot of the drama makes plain why the original title was *Campo di maggio*. According to Forzano and Mussolini's portrayal, Napoleon, the great hero of this historical tragedy, is unsuccessful not because of the superiority of his military opponents or because of his personal failures, but because of democracy in the form of parliamentarianism: In a state of emergency, when France is surrounded by enemies, the very same liberal constitution that was declared on the Mayfield prevents the emperor from defending his country. Instead of coming together patriotically behind Napoleon, the elected representatives of the people allow themselves to be blinded by Fouché, a conniving, lying, extorting, cajoling career politician who is concerned only for his own self-interest. In contrast, Napoleon appears in the play as a brave soldier and loving family man, as a man of the people and charismatic genius who makes but a single—though grave—mistake in his hundred-day reign, namely not wanting to rule as a military dictator but as a constitutional monarch.²⁷⁶

This fundamental conflict—Napoleon/people vs. Fouché/parliament—is the clear leitmotif of *Campo di maggio* and the

- 275 See Mussolini and Forzano: *Hundert Tage*, pp. 61–140, quote p. 81 [our trans.].
 276 According to Volker Hunecke, this decision was based on Napoleon's unconditional demand to remain emperor: *Napoleons Rückkehr*, pp. 89 and 96. Munro Price emphasizes that Napoleon indeed had the opportunity to abdicate in favor of his son with Marie Louise as regent *before* Waterloo, but he chose to wage war and hence destroyed his dynasty and inflicted great damage on France: *Napoleon. The End of Glory*, New York/Oxford: Oxford University Press 2014, p. 257.

German translation *Hundert Tage*, but the Burgtheater production intensifies this even further.²⁷⁷ The text of the performance as documented in the promptbook was written by the dramatist and journalist Hanns Sassmann, whom Lothar calls an “arch Austrian” in his history of the Burgtheater from 1934,²⁷⁸ in collaboration with Manager Röbbeling, who also directed the play. Their reworking cuts out the second scene of the third act, where an envoy of Fouché encounters Wellington, changes some of the speaking roles, and makes revisions throughout the text. Sassmann and Röbbeling’s most consequential changes are made to Fouché, who in the promptbook’s parliament scene says:

*If a politician wants to win a majority, he must never attempt to prove his claims. The more reasonable arguments he puts forward, the less he is believed. Because, wherever even a hundred people converge en masse, they immediately take leave of their senses and are guided exclusively by their emotions, by their passion.*²⁷⁹

Although the minister of police expresses this remark as a complaint in front of the representatives, in fact he is skillfully capitalizing on the irrationality of the masses: in the play he possesses a masterful ability to direct their emotions and passions. Napoleon, by contrast, is the embodiment of the reason that the emotional parliamentarians lack. Far from despotically exploiting his imperial power, he always appears composed and under control; and when he does lose his poise, he regains his composure immediately. Despite his sovereign detachment, Napoleon represents the will of the common people, the artisans and farmers, the laborers and soldiers,

- 277 See Dietrich: “Burgtheaterpublikum und Öffentlichkeit in der Ersten Republik,” pp. 687–688, and the review of the premiere at the Burgtheater by David Josef Bach: “Das Ende einer Diktatur,” in: *Arbeiter-Zeitung* (Vienna), April 23, 1933, p. 7.
- 278 Lothar: *Das Wiener Burgtheater*, p. 13 [our trans.]. In the interwar period, Hanns Sassmann became known as the author of the “Austrian trilogy” staged at the Burgtheater: *Metternich* (October 1929), *Haus Rothschild* (January 1931), *1848* (December 1932). See Hüttner: “Die Staatstheater in den dreissiger Jahren,” pp. 70–72.
- 279 Promptbook *Hundert Tage*, Vienna: Georg Marton 1933, p. 63 [our trans.], source: Archive of the Burgtheater in Vienna, 609 R. This passage is contained in neither the Italian original nor in Herczeg’s German translation.



Fig. 65: Engelbert Dollfuss (front left) and Benito Mussolini (in bathing trunks), photographed in Riccione (Italy) on August 19, 1933. Source: Austrian National Library, H 2163.

who are betrayed by the advocates in parliament. “The house should not stand between me and the people,” Napoleon warns his cabinet: “Let the French people come to me again, I will know how to lead them.”²⁸⁰

These scenes depicting a reasonable leader, whose truthful representation of the people is thwarted by their elected representatives, unfolded at the Burgtheater while the Austrian parliament on the other side of Vienna’s Ringstrasse had been neutralized. Federal Chancellor **Engelbert Dollfuss**, who had been ruling by emergency decree since March 1933, said at the “Turks Deliverance Celebration” in the gardens of Schönbrunn Palace on May 14, 1933: “This form of parliament and parliamentarianism, which has died, will not return.”²⁸¹ What his government was now attempting to establish in Austria as a “corporative state” was not only politically and financially supported by the coauthor of *Hundred Days*, but was also ideologically based on Mussolini’s Fascism as an “organised, centralised, authoritarian democracy,”²⁸² which was supposed to bundle the will of the people in a sovereign leader.

Fig. 65, p. 161

280 Promptbook *Hundert Tage*, pp. 56–57 [our trans]. In Herczeg’s translation, this passage reads: “The house should not stand against me and the French people... Let the French people come to me again, I will know how to lead them...” See Mussolini and Forzano: *Hundert Tage*, p. 96 [our trans].

281 Cit. after “Unser Weg ist der einzig richtige!,” in: *Wiener Mittagsblatt* (Vienna), May 15, 1933, pp. 4–5, here p. 4 [our trans].

282 Mussolini: “The Doctrine of Fascism,” p. 23.

1.5 Reframing: “Anthem Chaos”



place	Corner of Mariahilfer and Linzer Strasse
moment	Singing the <i>Deutschlandlied</i>
space	N 48.190367° E 16.322840°
time	1932 a 133 d 11 h 30 min p. Chr.

II.10 The “**Turks Deliverance Celebration**” (*Türkenbefreiungsfeier*) in
 III.2.2 Vienna on May 14, 1933, was **filmed** for the *Fox Tönende Wochen-*
schau, the German edition of *Fox Movietone News*. At the end of
 III.1.3 the rally in the **gardens of Schönbrunn Palace**, the surviving
 recordings, with both audio and video intact,²⁸³ show airplanes
 of the Homeland Protection (*Heimatschutz*) flying from the
 Gloriette over the parterre to the palace building. The assem-
 bled Home Guard (*Heimwehr*) members cheer and wave while
 a military band plays the Austrian national anthem.²⁸⁴ In the
 III.2.1 & next scenes of the newsreel, the ensuing **Home Guard parade**
 Fig. 74, p. 186 along the Mariahilfer Strasse can be seen near the Technical
 Museum, where National Socialists raise their arms in a Hitler
 salute and sing the *Deutschlandlied*, evidently in protest against
 the marching Homeland Protectors. The melody sounds the
 same in both cases, but in Schönbrunn it is only instrumental,
 whereas during the protests the following lyrics can be heard:
 “Deutschland, Deutschland über alles, über alles in der Welt!”
 (literally, “Germany, Germany above all, above all else in the
 world!”). How did it come to pass that at the “Turks Deliverance
 Celebration” in Vienna on May 14, 1933, one and the same melody
 was used for opposing aims, namely in support of the Austrian
 state’s preservation and its annexation by the German Reich?

283 See “Die Türkenbefreiungsfeier des österreichischen Heimatschutzes in Wien,” in: *Jahresschau 1933 der Bundespolizeidirektion in Wien. Eine Chronik im Laufbild*, 35 mm film, source: Filmarchiv Austria, JS 1933/8.

284 As the planes cannot be heard, it is possible that the soundtrack was added later. However, a report by the Federal Police Headquarters in Vienna from May 15, 1933, confirms that the national anthem was played at the “Turks Deliverance Celebration,” see Austrian State Archives (ÖStA/AdR, BKA-I, 148.459/33).

The immediate cause of this “anthem chaos” lay in political decisions made in Austria in late 1929, early 1930.²⁸⁵ In truth, however, this question dates back to late-eighteenth-century Vienna, when Joseph Haydn was commissioned to compose a song of praise for the then emperor, Francis II. His piece, *Gott, erhalte den Kaiser* (“God Preserve the Emperor”), evolved with alternate lyrics into the Austrian imperial anthem, but also served in 1841 as the musical foundation for the *Lied der Deutschen* (“Song of the Germans”) by the German philologist and poet August Heinrich Hoffmann, who came from the north German village of Fallersleben, a song that would go on to be declared the national anthem of the Weimar Republic in 1922. In contrast, the Austrian chancellor, the Social Democrat Karl Renner, felt that the melody’s monarchical history made it an unsuitable symbol for a republican state, which is why he himself wrote an anthem for *Deutschösterreich* (“German-Austria”) in 1920 and had his friend Wilhelm Kienzl set it to music. Scarcely ten years later, the ruling Christian Social Party used a constitutional reform as an opportunity to officially introduce the former “Emperor’s Song” (*Kaiserslied*), now with new lyrics by the priest and poet Ottokar Kernstock, as the Austrian national anthem. Consequently, when Haydn’s traditional melody was played in Vienna in the early 1930s, it could have been praising three different political sovereigns: the Habsburg emperor, the German people, or the Austrian state.

III.1.4 “God Preserve the Emperor” was created at a time when the monarch certainly could have benefited from some divine assistance.²⁸⁶ Even before Francis, the heir to the Habsburg throne, was crowned emperor of the Holy Roman Empire of the German Nation in July 1792, revolutionary France had declared war on him in April. The military conflicts dragged on for years, with victories and defeats on both sides, until the French army under **Napoleon Bonaparte** resoundingly prevailed over Austrian troops in northern Italy. These

285 See “Hymnenchaos,” in: *Neue Freie Presse* (Vienna), February 14, 1930 (morning edition), pp. 1–2.

286 On the following, see Franz Grasberger: *Die Hymnen Österreichs*, Tutzing: Hans Schneider 1968, pp. 11–12.

decisive battles were fought in 1796, the year when Count Franz Josef von Saurau, then the provincial president of Lower Austria, commissioned the “meritorious poet” Lorenz Leopold Haschka to write “a national song just like that of the English,” which would proclaim “to the whole world the people’s loyal allegiance to their good and righteous sovereign.”²⁸⁷ While the song *God Save the King*, which had been sung in honor of British kings since the mid-eighteenth century, served as the model, the commissioned piece was probably also directed against the militant *Marseillaise*, which had originated with the declaration of war against Austria and had been the French national anthem since 1795.

Thematically, Haschka closely aligned his words with the English model, likewise calling on god to protect the monarch. Metrically, however, he did not abide by the three-quarter time of *God Save the King* with its mostly dactylic feet of one stressed and two unstressed syllables: “Send him victorious, / Happy and glorious,” etc.²⁸⁸ Instead, for his lyrics, Haschka opted for the (double) ballad stanza then very common in German poetry, choosing the title *Gott, erhalte den Kaiser* (“God Preserve the Emperor”).²⁸⁹

*Gott! erhalte Franz den Kaiser,
Unsern guten Kaiser Franz!
Lange lebe Franz der Kaiser
In des Glückes hellstem Glanz!
Ihm erblühen Lorber-Reiser,
Wo Er geht, zum Ehren-Kranz!
Gott! erhalte Franz den Kaiser,
Unsern guten Kaiser Franz!*

*God preserve our Emp’ror Francis,
Sov’ reign ever good and great!
Save, O save him from mischances
In felicity and state!
May his days be crown’d with glory,
Laurel wreathes his pate may braid!
God preserve our Emp’ror Francis,
Sov’ reign ever good and great!*

- 287 Count Franz Josef von Saurau to the Count of Court Music (*Hofmusikgraf*) Moritz Dietrichstein in a letter from February 28, 1820, cit. after Grasberger: *Die Hymnen Österreichs*, p. 13 [our trans.].
- 288 Cit. after *The Gentleman’s Magazine* (London), 15 (1745), p. 552.
- 289 On the form and prevalence of the German ballad stanza, see Horst Joachim Frank: *Handbuch der deutschen Strophenformen*, Tübingen: Francke 1993, pp. 180–187 and 621–626.

*Lass von Seiner Fahnen Spitzen
Strahlen Sieg und Furchtbarkeit!
Lass in Seinem Rathe sitzen
Weisheit, Klugheit, Redlichkeit;
Und mit Seiner Hoheit Blitzen
Schalten nur Gerechtigkeit!
Gott! erhalte Franz den Kaiser,
Unsern guten Kaiser Franz!*

*Ströme deiner Gaben Fülle
Über Ihn, Sein Haus und Reich!
Brich der Bosheit Macht; enthülle
Jeden Schelm- und Buben-Streich!
Dein Gesetz sey stets Sein Wille;
Dieser uns Gesetzen gleich!
Gott! erhalte Franz den Kaiser,
Unsern guten Kaiser Franz!*

*Froh erleb' Er Seiner Lande,
Seiner Völker höchsten Flor!
Seh' sie, Eins durch Bruder-Bande,
Ragen allen Andern vor;
Und vernehme noch am Rande
Später Gruft der Enkel Chor:
Gott! erhalte Franz den Kaiser,
Unsern guten Kaiser Franz!²⁹⁰*

*From his glorious banners streaming,
May success and plenty grow!
In his councils brightly beaming,
O may wisdom, prudence flow;
Fill the hearts of his advisers
With integrity and grace!
God preserve our Emp'ror Francis,
Sov'reign ever good and great!*

*All thy bounties good and gracious
Pour on him, his house, and realm!
And in mercy, plots audacious
With confusion overwhelm!
By thy law may he be guided,
Our laws his will creates!
God preserve our Emp'ror Francis,
Sov'reign ever good and great!*

*May he see his countries flourish
And his peoples crown'd with joy!
Love fraternal may they nourish
And all seeds of hate destroy!
May he hear his offspring crying
When on brink of distant grave:
God preserve our Emp'ror Francis,
Sov'reign ever good and great!²⁹¹*

From a formal perspective, every stanza of the German original comprises eight so-called trochaic tetrameters, with an abab rhyme scheme and alternately stressed and unstressed line endings. That means that in the uneven verses there are

290 Cit. after the first print *Gott, erhalte den Kaiser! Verfasset von Lorenz Leopold Haschka, In Musik gesetzt von Joseph Haydn, Zum ersten Mahle abgesungen den 12. Februar, 1797*, source: Austrian National Library, Mus.Hs.16501.

291 Cit. after *Hymn for the Emperor Francis. Composed by Dr. Haydn & Sung at the public Theatres at Vienna in the manner of God Save Great George Our King in England. Set as a Duet & Chorus with a Piano Forte. Accompaniment by I.B. Cimador, London: Monzani & Cimador [ca. 1800, trans. reworked]*, source: The British Library, Digital Store Tyson P.M.15.(13.).

four stressed and four unstressed syllables after one another, and in the even verses the last unstressed syllable is missing. In the refrain, the song's chorus, the words "Gott/God" and "Franz/Francis" are thus not only repeated, but also emphasized. This regular emphasis corresponds to the prayer-like nature of the lyrics, which ask god to protect Francis as the victorious, well-advised, and legitimate emperor. Although Count Saurau, the initiator, speaks of a "national song," it is not in fact about a nation living together according to its own laws. Rather, several "countries" and "peoples" are united under the monarchical sovereign, whose divinely inspired will is the law for his subjects: "By thy law may he be guided, / Our laws his will creates!" ("Dein Gesetz sey stets Sein Wille; / Dieser uns Gesetzen gleich!").

Therefore, Haschka delivered what had been expected of him, namely a hymn to the emperor, realized in a lyrically familiar form that had been used, for example, by Friedrich Schiller in his *Ode to Joy*, published in 1786.²⁹² Between October 1796 and January 1797, Haschka's text was set to music by Joseph Haydn, who had heard *God Save the King* in England and had himself suggested the creation of a similar national song in Austria.²⁹³ He was very fond of the result, his "**Emperor's Song**" (*Kaiserlied*), and not only did he vary the melody immediately in the "Kaiserquartett" ("Emperor's Quartet," op. 76, no. 3), but toward the end of his life he supposedly played it daily on the piano.²⁹⁴ "God Preserve the Emperor" was first performed on the occasion of the twenty-ninth birthday of Francis II on February 12, 1797, at the **Hofburgtheater** in Vienna. The lyrics were distributed among the audience on handbills and sung to Haydn's score in the first interval of the opera performance. As the ministerial *Wiener Zeitung* reported ten days later, the "national song" had been written by the "most famous composer

Fig. 66, p. 167

III.1.4 &
Fig. 62, p. 154

292 Friedrich Schiller: "An die Freude," in: *Thalia* (Leipzig), 1/2 (1786), pp. 1–5. In 1985, the ode in Beethoven's setting was declared the anthem of the European Union.

293 See Thomas Leibnitz: "'Gott! erhalte...' Joseph Haydn's Kaiserlied und die Hymnen Österreichs," in: Thomas Leibnitz (ed.): *Joseph Haydn. Gott erhalte. Schicksal einer Hymne*, Vienna: Österreichische Nationalbibliothek 2008, pp. 8–69, here pp. 17–21.

294 See Leibnitz: "'Gott! erhalte...,'" pp. 27–33.

Langsam.

Gott! er = hal = te Franz den Kai = ser, Unfern guten Kai = ser Franz! Lange le = be Franz der Kai = ser In des Glü = des hellstem Glanz! Ihm er = blühen Lorber = Rei = ser, wo Er geht, zum Ehren = Kranz! Gott! er = halte Franz den Kai = ser, Unfern gu = ten Kai = ser Franz!

Fig. 66: First print of *Gott, erhalte den Kaiser* (“God Preserve the Emperor,” piano arrangement), lyrics by Lorenz Leopold Haschka, music by Joseph Haydn, premiered at the Hofburgtheater in Vienna on February 12, 1797. Source: Austrian National Library, Mus.Hs.16501.

of our age” and was received with enthusiasm by both the “dear sovereign” and his “loyal subjects.”²⁹⁵

Gott erhalte was created as an ode to the last emperor of the Holy Roman Empire of the German Nation. However, the song only became the official imperial anthem after **Francis II** had proclaimed the Austrian Empire in 1804, in light of Napoleon’s designation as Emperor of the French, and had abdicated as German emperor in 1806, in light of the founding of the Confederation of the Rhine by Napoleon. He dissolved the Holy Roman Empire and now reigned as **Francis I**, Emperor of Austria, the Habsburg crown lands. It was predominantly in **1809** that the *Gott erhalte* anthem was used officially, when the Austrian army under Archduke Charles, the emperor’s brother, first conquered the Napoleonic troops,

Fig. 67, p. 168

Fig. 68, p. 168

II.2

295 “Inländische Begebenheiten,” in: *Wiener Zeitung* (Vienna), February 22, 1797, pp. 537–541, here pp. 537–538 [our trans.].



Fig. 67: Francis II as Holy Roman Emperor of the German Nation (1797). Source: Austrian National Library, PORT_00048214_01.



Fig. 68: Francis I as Emperor of Austria (ca. 1805). Source: Austrian National Library, PORT_00048185_02.

and then in 1814/15 at numerous events in the context of the Congress of Vienna, where Europe's national borders were redrawn after the abdication of Napoleon.²⁹⁶ That the hymn was only adopted by the army in 1826, three decades after its creation, might be related to Haydn's solemn melody, which was not well suited as a battle cry. However, another reason is the lacking nationality of this multilingual army, which was "Austrian" in name only.²⁹⁷

After Francis I died in 1835, two new sets of lyrics were written for his son Ferdinand, but they both remained unpopular.²⁹⁸ Then, under Emperor **Francis Joseph I**, the demand made by the writer Adalbert Stifter and others for the

Fig. 79, p. 196

296 See Grasberger: *Die Hymnen Österreichs*, pp. 58–60.

297 See Leibnitz: "Gott! erhalte...," pp. 36–37.

298 On this and the following, see Leibnitz: "Gott! erhalte...," pp. 41–49.

creation of generally applicable, permanent lyrics was finally met. The poet suggested by Stifter, namely Franz Grillparzer, reluctantly attempted the task, but even he was dissatisfied with the result. Ultimately, a draft by Johann Gabriel Seidl was chosen, at the time the curator of the imperial royal coin and antiquities collection, whose new “People’s Hymn” (*Volkshymne*) was published in the *Wiener Zeitung* on April 9, 1854. Aside from a variable additional stanza, Seidl’s text no longer honors the individual ruler but begins with the lines: “Gott erhalte, Gott beschütze / Unsern Kaiser, unser Land!” (literally, “God preserve, God protect / Our emperor, our country!”). At the end of the first stanza, the name of this country is uttered, though “Austria’s destiny” (“Österreichs Geschick”) remains closely tied to “the Habsburg throne” (“Habsburgs Throne”). The “Emperor’s Song” had thus evolved into a kind of family hymn, which quotes two Habsburg mottoes in the fourth stanza:

<i>Lasst uns fest zusammenhalten:</i>	<i>Let us stand together firmly:</i>
<i>In der Eintracht liegt die Macht;</i>	<i>Concord is so powerful;</i>
<i>Mit vereinter Kräfte Walten</i>	<i>Ruling with united forces</i>
<i>Wird das Schwerste leicht vollbracht.</i>	<i>Deeds are done just masterful.</i>
<i>Lasst uns Eins durch Brüderbande</i>	<i>Let us join fraternally and</i>
<i>Gleichem Ziel entgegengeh'n;</i>	<i>March together to one score;</i>
<i>Heil dem Kaiser, Heil dem Lande:</i>	<i>Hail the Emp'ror, hail the country:</i>
<i>Österreich wird ewig steh'n!</i>	<i>Austria forevermore!²⁹⁹</i>

Despite the title “People’s Hymn,” once again the emperor is at the center of both the lyrics and the country over which he rules by the grace of god. In keeping with Francis Joseph’s motto, *Viribus unitis*, Austria’s heterogeneous forces should be united in the sovereign monarch. “Austria,” though, is the name of a territory whose borders changed from century to century. Yet the House of Habsburg would last “forevermore,” at least in the common interpretation of the symbolic device AEIOU as *Austria erit in orbe ultima*, which Frederick III had inscribed on his property in the fifteenth century. Seidl’s hymn

299 Cit. after “Volkshymne,” in: *Wiener Zeitung* (Vienna), April 9, 1854, p. 2 [our trans.].

text proved as enduring as Habsburg rule: it remained the official lyrics until the end of the monarchy in the fall of 1918.

In the second half of the nineteenth century, yet another text was sung to Haydn's melody, though this version pertained less to a "father of the land" (*Landesvater*) and more to the German "fatherland" (*Vaterland*). These lyrics had originated on the then British island of Helgoland in the North Sea in 1841, where the German philologist and poet August Heinrich Hoffmann was spending his summer vacation. Hoffmann, who called himself "von Fallersleben" after the village where he was born, had been a professor of German language and literature at the University of Breslau (now Wrocław, Poland) since 1830 and had just published his *Unpolitische Lieder* ("Unpolitical Songs"). In the first volume, published in 1840, there is a poem called "The German Customs Union" (*Der deutsche Zollverein*), which begins with a list of duty-free wares:

<i>Schwefelhölzer, Fenchel, Bricken,</i>	<i>Wooden plates, old rags, and matches,</i>
<i>Kühe, Käse, Krapp, Papier,</i>	<i>Pigment, paper, salt, and steers,</i>
<i>Schinken, Scheeren, Stiefel, Wicken,</i>	<i>Ham and scissors, boots and vetches,</i>
<i>Wolle, Seife, Garn und Bier;</i>	<i>Woolens, cheeses, soaps, and beers;</i>
<i>Pfefferkuchen, Lumpen, Trichter,</i>	<i>Fennel, funnels, gingerbread, and</i>
<i>Nüsse, Tabak, Gläser, Flachs,</i>	<i>Nuts, tobacco, glasses, flax,</i>
<i>Leder, Salz, Schmalz, Puppen, Lichter,</i>	<i>Leather, lights, lard, puppets, thread, and</i>
<i>Rettig, Rips, Raps, Schnaps, Lachs, Wachs!</i>	<i>Radish, rep, rape, schnapps, and wax!³⁰⁰</i>

Fig. 72, p. 176

The second stanza thanks the listed merchandise for tying a stronger bond around the "German fatherland" than the sovereign princes of the **German Confederation**. The poem mocks this association of states forged in 1815 at the Congress of Vienna, but does so not merely thematically, but also through its metric structure, which corresponds to that of the hymn for the Austrian emperor, who held the nominal presiding power (*Präsidialmacht*) of the German Confederation. Although Hoffmann von Fallersleben lost his professorship due to his *Unpolitische Lieder*, he soon gained fame as a poet

300 Hoffmann von Fallersleben: "Der deutsche Zollverein," in: *Unpolitische Lieder*, Hamburg: Hoffmann und Campe 1840, p. 46 [our trans.].

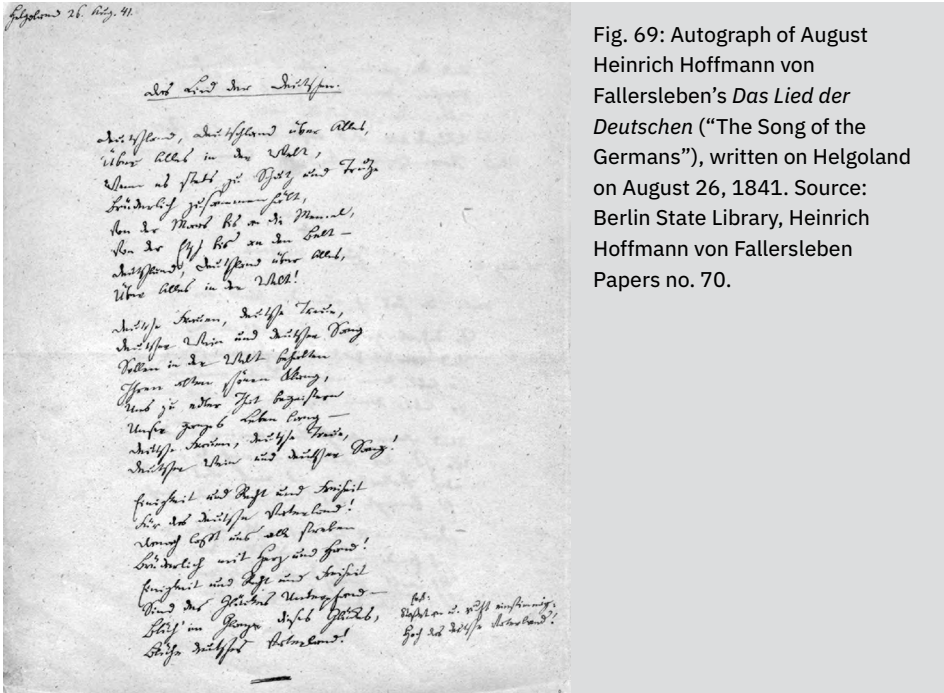

Fig. 69: Autograph of August Heinrich Hoffmann von Fallersleben's *Das Lied der Deutschen* ("The Song of the Germans"), written on Helgoland on August 26, 1841. Source: Berlin State Library, Heinrich Hoffmann von Fallersleben Papers no. 70.

Fig. 69, p. 171

and singer.³⁰¹ Another commercial success was *Das Lied der Deutschen* ("The Song of the Germans"), written in late August 1841 on Helgoland, which he immediately published with Hoffmann und Campe in Hamburg.³⁰² The title page of this first edition expressly notes (originally in German, here translated): "Melody after Joseph Haydn's: 'God preserve our Emp'rour Francis, / Sov'reign ever good and great!'" Austria, where Ferdinand I had reigned since 1835, does not exist in the *Deutschlandlied* ("Song of Germany"), which reworks the hymn of the last Roman-German emperor into an anthem for a future German nation.

301 See Bernt Ture von zur Mühlen: *Hoffmann von Fallersleben. Biographie*, Göttingen: Wallstein 2010, pp. 191–234.

302 See Hoffmann von Fallersleben: *Mein Leben. Aufzeichnungen und Erinnerungen. Dritter Band*, Hannover: Carl Rumpeler 1868, pp. 211–212.

*Deutschland, Deutschland über Alles,
Über Alles in der Welt,
Wenn es stets zu Schutz und Trutze
Brüderlich zusammenhält,
Von der Maas bis an die Memel,
Von der Etsch bis an den Belt –
Deutschland, Deutschland über Alles,
Über Alles in der Welt!*

*Germany 'bove ev'rything, yes,
Ev'rything within the world,
If she always stands together
For protection unreserved,
From the Maas right to the Memel,
Adige up to the Belt—
Germany 'bove ev'rything, yes,
Ev'rything within the world!*

*Deutsche Frauen, deutsche Treue,
Deutscher Wein und deutscher Sang
Sollen in der Welt behalten
Ihren alten schönen Klang,
Uns zu edler That begeistern
Unser ganzes Leben lang –
Deutsche Frauen, deutsche Treue,
Deutscher Wein und deutscher Sang!*

*German women, German loy'lty,
German wine and German song,
All around the world they shall be
Heard with voices loud and strong,
And inspire noble actions
From the youth and ev'ryone—
German women, German loy'lty,
German wine and German song!*

*Einigkeit und Recht und Freiheit
Für das deutsche Vaterland!
Danach lasst uns alle streben
Brüderlich mit Herz und Hand!
Einigkeit und Recht und Freiheit
Sind des Glückes Unterpfand –
Blüh' im Glanze dieses Glückes,
Blühe, deutsches Vaterland!*

*Unity and right and freedom
For the German fatherland!
For this goal let's strive together
Brotherly with heart and hand!
Unity and right and freedom
Shall be our fortune's stand—
Flourish, thrive right in this fortune,
Flourish, German fatherland!³⁰³*

From a rhetorical perspective, Hoffmann's text begins with an ellipsis and hyperbole. In other words, the formulation of the first two lines is incomplete and exaggerated. It is not clear whether Germany is *loved* or *placed* above everything. Are these lines intended to express longing for a German nation state or claim its supremacy? The following lines do not provide any more clarity, because both patriotism and national superiority can depend on the people uniting fraternally to defend their country. Regarding the exaggeration, the word

303 Cit. after Hoffmann von Fallersleben: *Das Lied der Deutschen*. Arrangiert für die Singstimme mit Begleitung des Pianoforte oder der Gitarre, Hamburg: Hoffmann und Campe, September 1, 1841 [reprint from 1923, our trans.], source: Austrian National Library, MS9451-4°.

“everything” denotes either that which is important to a person or, quite differently, the other nations of the world. According to how the two lines are interpreted, they introduce either a patriotic or a nationalistic poem.

The biography of the liberally minded author rather substantiates the patriotic reading. However, that the opening lines presumably allude to the following dictum, speaks for the nationalist interpretation: “Austria above everything, if she only will!” (“Österreich über alles, wenn es nur will!”). It dates back to a **book** by the cameralist Philipp Wilhelm von Hörnigk

Fig. 70, p. 173

that was published in 1684 with the full title: “Austria Above Everything, If She Only Will. That Is: Well-Meaning Suggestion How, with the Aid of a Thriving National Economy,

Fig. 78, p. 196

the Imperial Hereditary Land Might before Long Rise above All Other States in Europe / and More Than Some / Become Independent of Them.”³⁰⁴ In the year after Vienna’s liberation from the Ottoman siege, the text recommends that **Leopold I**, the emperor of the Holy Roman Empire of the German Nation, make his hereditary lands economically independent. The aim of this autarky was Austria’s political assertion over

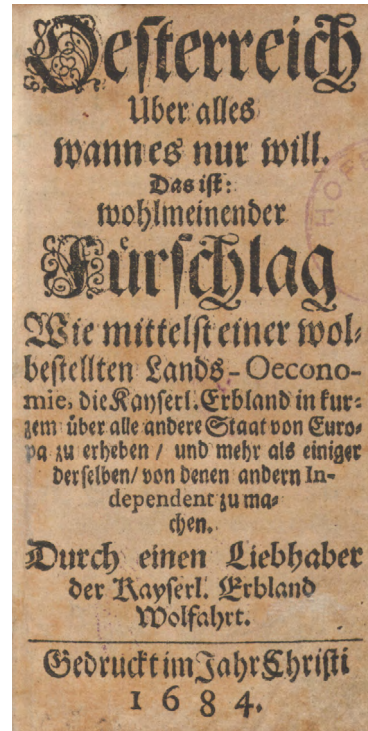

Fig. 70: Title page of the book *Austria Above Everything If She Only Will* (1684) by Philipp Wilhelm von Hörnigk. Source: Austrian National Library, 35.Z.59.

304 Philipp Wilhelm von Hörnigk: *Oesterreich Über alles wann es nur will. Das ist: wohlmeinender Fürschlag Wie mittelst einer wolbestellten Lands-Oeconomie die Kayserl. Erbland in kurzem über alle andere Staat von Europa zu erheben / und mehr als einiger derselben / von denen andern Independent zu machen*, [without place and publisher] 1684.



Fig. 71: Propaganda poster for the Fatherland Front (*Vaterländische Front*), founded as the Austrian state party in May 1933, from summer 1933. The text reads: “Austria above everything! Our Federal Chancellor Dr. Dollfuss calls: Those who love and want to protect Austria join the Fatherland Front! Registration at Vienna I, Bäckerstrasse 13.” Source: Austrian National Library, PLA16304627.

absolutist France under Louis XIV. For Heinrich Gerstenberg, who edited Hoffmann’s works and in 1933 published a study on the *Deutschlandlied*, Hörnigk’s book comprised the “cradle of our German national anthem.”³⁰⁵ However, the book’s title was also claimed by Austrian Federal Chancellor Engelbert Dollfuss, who at the end of his speech at the “Turks Deliverance Celebration” on May 14, 1933, quoted “a simple, old German word”: “Austria above everything, if she only will!”³⁰⁶ The line became the catchphrase of the **Fatherland Front**—the

Fig. 71, p. 174

- 305 Heinrich Gerstenberg: *Deutschland über alles! Vom Sinn und Werden der deutschen Volkshymne*, Munich: Ernst Reinhardt 1933, pp. 11–18 [our trans.]. In the foreword, the author expresses “the pleasing gratification to see this ‘Song of the Germans’ snowball into the great German national movement of the present and to be able to steer its history to this awakening of the nation” (before p. 1 [our trans.]); he is referring here to the National Socialist “seizure of power.”
- 306 Cit. after “Unser Weg ist der einzig richtige!,” in: *Wiener Mittagsblatt* (Vienna), May 15, 1933, pp. 4–5, here p. 5 [our trans.].

Austrian state party under Dollfuss' authoritarian leadership, the foundation of which was announced in the *Wiener Zeitung* one week after the mass rally in Schönbrunn.³⁰⁷

So Hoffmann's text loves or places Germany—instead of Austria—“above everything.” But what is meant by “Germany”? The territory of the yearned-for nation state is defined in the first stanza with reference to four rivers or waters: “From the Maas right to the Memel, / Adige up to the Belt” (“Von der Maas bis an die Memel, / Von der Etsch bis an den Belt”). According to the anthem, therefore, this “Germany” ranged roughly from the Prussian-Netherlandish (Maas) to the Prussian-Lithuanian (Memel) border and from the Baltic Sea (Belt) to South Tirol (Adige). Especially in the east, the territory of the *Deutschlandlied* extends far beyond that of the **German Confederation** in 1841. What Hoffmann had in mind was clearly not the existing political boundaries, but rather the border regions of the German language.³⁰⁸ Influenced by Romantic literature and the work of the Brothers Grimm, his philological studies were supposed to help document Germanity.³⁰⁹ Hoffmann's research into German folksong had a formative influence on his poems. From this German philological perspective, Austria, whose German-speaking territories were included in the “Song of the Germans,” was not able to form its own nation state.

The National Socialists, who protested against the Home Guard parade in Vienna on May 14, 1933, sang the first stanza of the *Deutschlandlied* quite in the sense of a Greater German nation, which had been called for as long ago as the Revolution of 1848. However, whereas national liberalism had

Fig. 72, p. 176

- 307 See “Hinein in die vaterländische Front!,” in: *Wiener Zeitung* (Vienna), May 21, 1933, p. 3.
- 308 See Herbert Blume: “Maas, Memel, Etsch und Belt. Die Gewässer in Hoffmanns *Lied der Deutschen* und die Grenzen des ‘Vaterlands,’” in: Marek Hatub and Kurt Schuster (eds.): *Hoffmann von Fallersleben. Internationales Symposium Wrocław/Breslau 2003*, Bielefeld: Verlag für Regionalgeschichte 2005, pp. 247–265.
- 309 See Gabriele Henkel: “‘Wie freu ich mich der hellen Tage!’ Ergänzende Anmerkungen zum Thema ‘Hoffmann und die Romantik,’” in: Bettina Greffrath, Gabriele Henkel, Christin Langermann (eds.): *Hoffmann von Fallersleben. Dichter, Germanist und singender Freiheitskämpfer*, Hildesheim: Olms 2015, pp. 36–43.



Fig. 72: The territory of the German Confederation in 1841 with the rivers or waters named as the border regions of Germany in Hoffmann von Fallersleben's *Lied der Deutschen*, represented by Stefan Amann based on open data from Wikipedia.

been advocating “unity and right and freedom,” as it says in Hoffmann’s text, the supporters of the Nazi regime could hardly appeal to the rule of law and civil liberties. When in 1922 the president of the German Reich, the Social Democrat Friedrich Ebert, declared the “Song of the Germans” the national anthem of the Weimar Republic, he referred explicitly to the third stanza, which has also been sung as the national

anthem of the Federal Republic of Germany since 1952.³¹⁰ In contrast, the Nazi regime combined the first stanzas of the *Deutschlandlied* and the *Horst-Wessel-Lied*, the NSDAP's martial party anthem. It was in this order that the songs were sung at the National Socialist "Turks Deliverance Celebration" on May 13, 1933, at Vienna's **Engelmann Arena**, an event that was directed against the rally held by the Austrian Homeland Protection the following day.³¹¹

At the "Turks Deliverance Celebration" in the gardens of Schönbrunn Palace, the band also played Haydn's melody. Which lyrics the assembled Home Guard members sang to it, however, is unclear. Whether by force of habit or out of conviction, many Homeland Protectors might still have sung Seidl's verses from 1854, which had honored the Habsburg emperor until the end of World War I. It is quite probable that only a minority would have known by heart the new lyrics by Ottokar Kernstock, which were declared the national anthem in 1929. Besides, it was not the words that were important, but the fact that it was Haydn's song that was now able to ring out again, rather than the unofficial anthem *Deutschösterreich* ("German-Austria") from 1920, which had been composed by Wilhelm Kienzl. This almost ten-year interlude harked back to Karl Renner's decision not to use the melody of the "Emperor's Song" for the newly founded republic.³¹² However, as the federal army needed an anthem to swear in the troops, the Social Democratic state chancellor himself wrote a text, which extolled "German-Austria" as a "glorious country" and "hardworking people."³¹³ Kienzl set his friend's not especially poetic verses to music, though by his own account he did so unwillingly because his composition had to replace "Haydn's immortal melody."³¹⁴

310 See Kathrin Schellenberg: "Das Lied der Deutschen – Geschichte und Rezeption," in: Bettina Greffrath, Gabriele Henkel, Christin Langermann (eds.): *Hoffmann von Fallersleben. Dichter, Germanist und singender Freiheitskämpfer*, Hildesheim: Olms 2015, pp. 215–233, here pp. 221 and 227–229.

311 See "Überwältigende Feier in der Engelmann-Arena," in: *Deutsch-österreichische Tages-Zeitung* (Vienna), May 14, 1933, p. 2.

312 See Leibnitz: "'Gott! erhalte...,'" pp. 59–61.

313 Cit. after "Die neue deutschösterreichische Hymne," in: *Illustrierte Kronen-Zeitung* (Vienna), June 28, 1920, p. 2 [our trans.].

314 Wilhelm Kienzl cit. after Grasberger: *Die Hymnen Österreichs*, p. 99 [our trans.].

His doubts were justified, since Renner and Kienzl's anthem proved neither generally known nor popular.

As a result of the discussion of state symbols in the context of the constitutional reform of 1929, in mid-December the cabinet approved a motion by the Christian Social Party to adopt Haydn's melody with lyrics by Ottokar Kernstock as the Austrian national anthem.³¹⁵ Renner's song had never officially been decreed, which is why the ministers responsible could simply give according instructions to their departments. Nonetheless, the corresponding decree by the Ministry of Education from January 31, 1930, was thwarted by the president of Vienna's education authority, the Social Democrat Otto Glöckel, with his directive to the schools of Vienna to sing the first and third stanzas of the *Deutschlandlied*. Glöckel's attempt "to promote the national and republican education of the young"³¹⁶ in this way was in conformity with the **Social Democratic party line** since the fall of 1918, according to which "German-Austria" should join the Weimar Republic. Another decree by the minister of education then specified that while there were generally no objections to be made to the *Deutschlandlied*, at official events exclusively Kernstock's lyrics were to be used.³¹⁷

The new verses for the old hymn had been created immediately after the end of World War I. Inspired by "patriotic fellow countrymen,"³¹⁸ the German Nationalist poet Ottokar Kernstock, who lived as a Catholic priest in Styria, wrote a poem to the tune of Haydn's "Emperor's Song," which was distributed on a handbill in Graz in 1919. In the original version, each of the stanzas ends in the line: "God with thee, German-Austria!" ("Gott mit dir, Deutschösterreich!").³¹⁹ For the version printed in his last volume of poetry *Der redende Born* in 1922, Kernstock changed not only "German-Austria"

315 See Johannes Steinbauer: *Land der Hymnen. Eine Geschichte der Bundeshymnen Österreichs*, Vienna: Sonderzahl 1997, pp. 75–78.

316 Decree of Vienna's education authority from February 12, 1930, cit. after "Die Haydn-Melodie in den Schulen," in: *Neue Freie Presse* (Vienna), February 13, 1930 (morning edition), p. 7 [our trans.].

317 See Steinbauer: *Land der Hymnen*, p. 98.

318 Ottokar Kernstock in a letter from August 26, 1927, cit. after Grasberger: *Die Hymnen Österreichs*, p. 121 [our trans.].

319 Cit. after Steinbauer: *Land der Hymnen*, p. 58 [our trans.].

to “my Austria” in keeping with the political circumstances, but also cut the third stanza, which started with the lines: “Eastern land you have been called and / From the East there comes the light” (“Osterland bis du geheissen, / Und vom Osten kommt das Licht”).³²⁰ As the conservative government did not want to associate the Austrian state with the “Bolshevist” East, the cabinet expressly declared only the “first, second, and fourth stanzas” the lyrics of the national anthem.³²¹

*Sei gesegnet ohne Ende,
Heimaterde wunderhold!
Freundlich schmücken dein Gelände
Tannengrün und Ährengold.
Deutsche Arbeit, ernst und ehrlich,
Deutsche Liebe, zart und weich –
Vaterland, wie bist du herrlich,
Gott mit dir, mein Österreich!*

*Bless'd be everlastingly, you
Wonderful and dear homeland!
Green of fir and gold of corn fields
Span thy country sweet and grand.
German labor, true and earnest,
German love, so singular—
Fatherland, how blissful thou art,
God with thee, my Austria!*

*Keine Willkür, keine Knechte!
Off'ne Bahn für jede Kraft!
Gleiche Pflichten, gleiche Rechte!
Frei die Kunst und Wissenschaft!
Starken Mutes, festen Blickes,
Trotzend jedem Schicksalsstreich,
Steig' empor den Pfad des Glückes,
Gott mit dir, mein Österreich!*

*Neither tyranny nor slav'ry!
Open way for every strength!
Equal rights and equal duties!
Free the arts and thoughts at length!
Sturdy spirits, steady gazes,
Brave and full of character,
Climb the ladder of good fortune,
God with thee, my Austria!*

*Lasst, durch keinen Zwist geschieden,
Uns nach einem Ziele schau'n!
Lasst in Eintracht und in Frieden
Uns am Heil der Zukunft bau'n!
Uns'res Volkes Jugend werde
Ihren starken Ahnen gleich!
Sei gesegnet Heimaterde!
Gott mit dir, mein Österreich!*

*Let's, by no discord divided,
Focus on a single goal!
Let's in unity and peaceful
Build our future as a whole!
Our people's offspring ought to
Reach their fathers' gloria!
Bless'd be our native soil, O
God with thee, my Austria!³²²*

320 Cit. after Steinbauer: *Land der Hymnen*, p. 58 [our trans.].

321 See the minutes of the Austrian government's cabinet meeting from December 13, 1929, in the Austrian State Archives (ÖStA/AdR, MRang, MR 1. Rep, MRP no. 603, pp. 21–23) [our trans.].

322 Ottokar Kernstock: “Österreichische Volkshymne,” in: *Der redende Born*, Graz: Leykam 1922, pp. 113–114 [our trans., emphasis in original].

Fig. 43, p. 119

Kernstock's verses read like a "mixture of 'Gott erhalte' and the *Deutschlandlied*."³²³ No longer is the emperor blessed, but the "native soil" ("Heimaterde"), which was called "German homeland" ("Deutsche Heimat") in the first version of the poem.³²⁴ "German" is a descriptor also applied to the "labor" and "love" of the people who live in this "fatherland." It is given the name "Austria" but is described as part of a German national community. That it could not be called "German-Austria," was set out under international law in the Treaty of Saint-Germain-en-Laye in 1919, which also laid down **the borders of the newly created state**.³²⁵ "Austria" was now no longer a monarchy, but a democratic republic, whose merits are highlighted by the anthem's second stanza. Although the third stanza reminds the reader or singer of the country's history, with its exemplary forefathers, it calls on its youth to recognize and work together to establish "our Austria constructed in the retort of the dictated peace, no, our crippled Austria," as the Christian Social *Reichspost* phrased it.³²⁶

III.1.2

After Haydn's melody had been created as an emperor's hymn, Hoffmann von Fallersleben reworked the song as a national anthem. By contrast, Kernstock wrote the lyrics for a state anthem, whose historical and cultural references raise awareness of the mutable nature of the word "Austria." Does it denote the property of a ruling dynasty, the sub-territory of an ethnic community, or an area bounded by international law? That the musical foundation of the anthem enabled all these interpretations became apparent not only at the "Turks Deliverance Celebration" on May 14, 1933, but also five years later, when the official validity period of Kernstock's verses ended. Under pressure from the Nazi regime, Federal Chancellor Kurt Schuschnigg announced his resignation on the evening of March 11, 1938, and closed his public address on

- 323 Gerald Stieg: *Sein oder Schein. Die Österreich-Idee von Maria Theresia bis zum Anschluss*, Vienna: Böhlau 2016, p. 47 [our trans.].
- 324 Cit. after Steinbauer: *Land der Hymnen*, p. 58 [our trans.].
- 325 See "Staatsvertrag von Saint-Germain-en-Laye vom 10. September 1919," in: *Staatsgesetzblatt für die Republik Österreich* (StGBL.), 90/303 (July 21, 1920), pp. 995–1245.
- 326 "Sei gesegnet ohne Ende!," in: *Reichspost* (Vienna), December 22, 1929, p. 4 [our trans.].

the radio “with a German word and a heartfelt wish: God save Austria!”³²⁷ His supporters bolstered his speech by shouting “Austria!,” whereupon the National Socialists present in the Federal Chancellery struck up the *Deutschlandlied*. In order to interrupt their singing, Schuschnigg’s brother Arthur, who was in charge of the concerts of phonograph recordings at *Radio Wien*, played an instrumental version of the German-Austrian anthem, namely the second movement of Haydn’s “Emperor’s Quartet.” Whether they witnessed a passing or an awakening was left to the listeners themselves to decide.³²⁸

- 327 Cit. after “Letzte Rundfunkansprache als Österreichischer Bundeskanzler von Kurt Schuschnigg am 11. März 1938” [our trans.], audiotape (AEG), source: Österreichische Mediathek, 99-38002_k02.
- 328 On these particular events in Vienna on March 11, 1938, see Franz Danimann: “Der 11. März 1938 in Wien,” in: Franz Danimann (ed.): *Finis Austriae. Österreich, März 1938*, Vienna: Europaverlag 1978, pp. 55–71, here p. 69, and Rudolf Henz: “Der März 1938. Die letzten Tage der RAVAG. Ein Dokument,” in: *morgen – Kulturzeitschrift aus Niederösterreich*, 2/3 (1978), pp. 29–32, here p. 32.

How to Capture Life: Examining Gazes

SPACE	LIMITED
TIME	FINITE
VALUE	RANKED
PERSPECTIVE	PANORAMA
NAVIGATION	PANNING

PARADE

2.1

The “Turks Deliverance Celebration” in Vienna on May 14, 1933, was organized by the Austrian Homeland Protection. After the rally in Schönbrunn, Home Guard members from all over the country marched along an imperial route into the center of “Red Vienna.”

CAMERA

2.2

There are several film recordings of the “Turks Deliverance Celebration.” The sound films derive from the German edition of *Fox Movietone News* and were taken with a Bell & Howell 35 mm camera—an upgraded version of the model 2709.

Fig. 73: The ranked network of the mediation “How to Capture Life: Examining Gazes” in the Topology module of the website *campusmedius.net* (version 2.0/2021), designed by Susanne Kiesenhofer and adapted for the book edition by Stefan Amann.

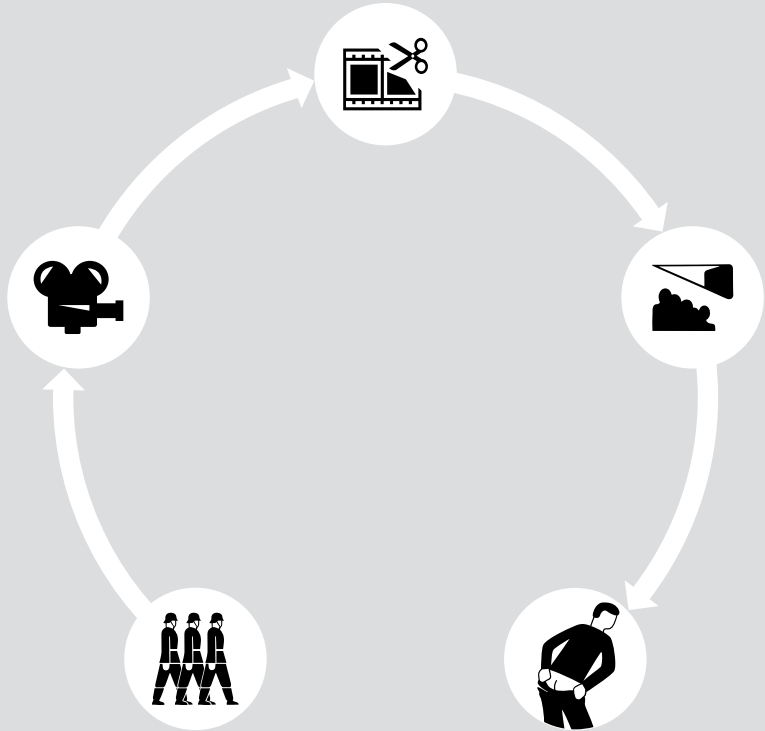

MONTAGE

2.3

The *N.S. Sound Image Report No. 2*, issued in summer 1933 by the NSDAP's propaganda headquarters in Berlin, deals with the affairs in Vienna on May 13 and 14, 1933, and manipulates the actual events in terms of not only the film's content, but also their temporal order.

CINEMA

2.4

On the weekend of the “Turks Deliverance Celebration,” the feature film *The Testament of Dr. Mabuse* by Fritz Lang was screened in eight movie theaters in Vienna, among them the UFA Ton Kino at Taborstrasse 8, which had opened as the Central Kino in the auditorium of Hotel Central in 1916.

EXPOSURE

2.5

When on Saturday, May 13, 1933, German Nazi politicians drove from Aspern airfield into Vienna's city center, some inhabitants of the Lassalle Hof showed them their exposed buttocks. How can this protest gesture be interpreted in terms of its cultural history?

2.1 Parade: March on Vienna



place	Schwarzenbergplatz
moment	Review of Home Guard troops
space	Start
time	End

II.10 &
Fig. 28, p. 79

The “**Turks Deliverance Celebration**” (*Türkenbefreiungsfeier*) in Vienna on May 14, 1933, was held by a paramilitary organization, which was composed of regional Home Guards (*Heimwehren*) and from 1931 called itself the Austrian Homeland Protection (*Österreichischer Heimatschutz*). The Habsburg Monarchy had collapsed at the end of World War I and the new **Republic of (German-)Austria** was still a fragile state. “We had heard of the soviet dictatorship in Hungary and Bavaria,” one of the first Home Guard members explained retrospectively, “and didn’t know how things would pan out, so we prepared for all eventualities.”³²⁹ In 1923 the associations in the western provinces joined forces as the so-called “Alpine Club” (*Alpenklub*) and elected the member of the Tyrolean provincial parliament Richard Steidle their chairman. Four years later, Steidle was also appointed the first federal leader of the Austrian Home Guards.³³⁰

Fig. 43, p. 119

Fig. 74, p. 186

This federal structure was reflected in the “Turks Deliverance Celebration,” to which **Home Guard members from all parts of Austria** traveled by chartered trains. Some formations wore their regional dress, but many abided by the instructions for the rally that had been published by the federal leadership and wore the green windbreaker that had served as the Home Guard uniform since 1927—together with a Tyrolean hat

329 Cit. after Walter Wiltschegg: *Die Heimwehr. Eine unwiderstehliche Volksbewegung?*, Vienna: Verlag für Geschichte und Politik 1985, p. 35 [our trans.].

330 See Wiltschegg: *Die Heimwehr*, pp. 35 and 42.

complete with grouse feather.³³¹ What the Homeland Protectors viewed as an expression of their down-to-earth attitude was considered by their political opponents, namely the Social Democrats, proof of just how provincial and backward the “rooster tails” (*Hahnenschwänzler*) were.³³² Like the Homeland Protection in general, the “Turks Deliverance Celebration” was intended to have a military quality. This being said, the ordinary participants in the parade were unarmed, and it could not be claimed that they had had professional combat training. While the first Home Guards had been founded by former soldiers who had equipped themselves with ex-army weapons, the military training of later, younger members was largely perfunctory. This was an organization of volunteers, meaning the men could take part in the gatherings and exercises, but they were not obliged to do so.³³³

- III.1.1 **Ernst Rüdiger Starhemberg** attempted to further the militarization of the Homeland Protection by fielding exemplary Home Guard troops in his homeland, the Mühlviertel in Upper Austria. With the fortune that he had inherited after his father’s death in 1927, Starhemberg armed some “ranger battalions” (*Jägerbataillone*) and marched through towns and cities with his men to appeal to the public. From a political perspective, his investments paid off; after all, he was appointed federal leader of the Austrian Home Guards in 1930. However, Starhemberg had incurred such debts in the process that he had to temporarily stand down from office. From 1932, funding
- III.1.4 came from **Benito Mussolini**, who had supported the Home Guards with money and weapons as early as 1927/28. It was also the Italian prime minister who paid for the “Turks Deliverance Celebration” on May 14, 1933, which was supposed to
- III.3.4 be orchestrated as a march on “**Red Vienna**.”³³⁴

331 See Arthur Karg-Bebenburg: *Weisungen für die Türkenbefreiungs-Gedenkfeier am 14. Mai 1933 in Wien*, Vienna: Österreichischer Heimatschutzverband 1933, p. 4.

332 See, for example, “Kein Aufmarschverbot für die Hahnenschwänzler!,” in: *Arbeiter-Zeitung* (Vienna), May 14, 1933, p. 3.

333 See Wiltschegg: *Die Heimwehr*, pp. 288–295.

334 See Lothar Höbelt: *Die Heimwehren und die österreichische Politik 1927–1936. Vom politischen “Kettenhund” zum “Austro-Fascismus”?*, Graz: Ares 2016, pp. 76, 185, 254–256, 271–272.

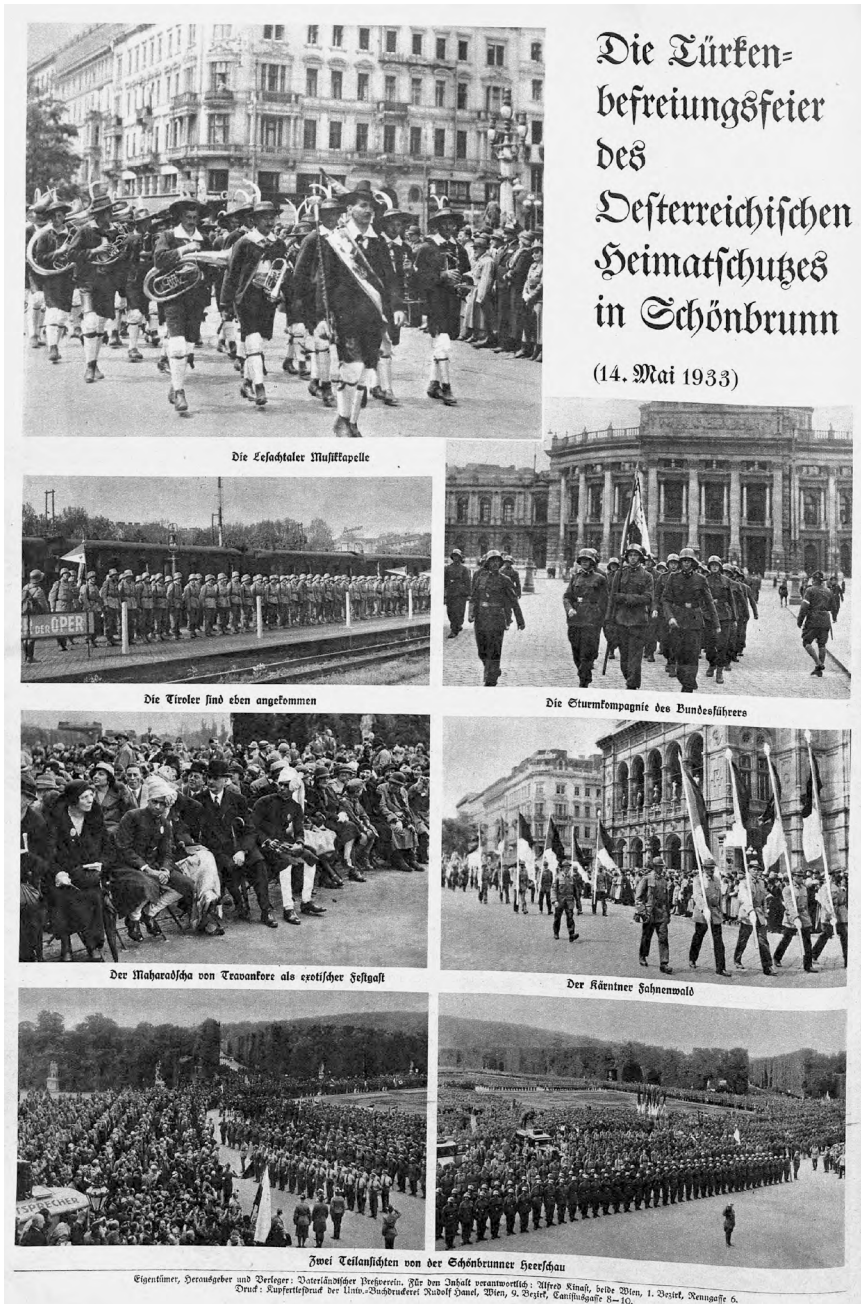

Fig. 74: Photo report on the “Turks Deliverance Celebration” held by the Austrian Homeland Protection in Vienna on May 14, 1933, printed in *Österreichische Heimat-schutzzeitung* (Vienna), 2/26 (July 1, 1933), supplement “Wehrfront im Bild,” p. 4. Source: Austrian National Library, 633589.

Whereas the Homeland Protection's own press spoke of over 40,000 men having taken part in the rally, the number of participants was estimated at under 20,000 in the newspapers of the opposition.³³⁵ In view of the fact that it was a military event, but only around 35,000 people were members of the armed units of the Austrian Homeland Protection in 1933,³³⁶ the number 40,000 does indeed seem too optimistic. However, the photographs and films of the parade do confirm **participation on a massive scale**, which probably surpassed the expectations of the federal leadership and their political opponents alike. As a thematic framework, Starhemberg—inspired by his **aristocratic family history**—had chosen Vienna's liberation from the Ottoman siege in 1683, the 250th anniversary of which would actually only fall in mid-September 1933. Besides, the speeches at the rally emphasized the *current* front lines, against National Socialism on the one hand, which was threatening Austrian sovereignty, but primarily against Social Democracy and the liberal worldview as a whole.³³⁷

Fig. 56, p. 143

Fig. 38, p. 107

This positioning was in keeping with Mussolini's demands of the policies implemented by Austrian Federal Chancellor **Engelbert Dollfuss**, whose cabinet had been ruling by emergency decree since early March 1933. Already on March 24, pre-censorship was imposed on the *Arbeiter-Zeitung*, the main organ of Austrian Social Democracy, and the Republican Protection League (*Republikanischer Schutzbund*), the Social Democratic counterpart to the Home Guards, was disbanded one week later.³³⁸ The ban on parades, which had prohibited the Viennese Social Democrats' traditional Labor Day Parade on May 1, was repealed for the "Turks Deliverance Celebration"

Fig. 65, p. 161

335 See, for example, "Riesentriumph des Heimatschutzes!" in: *Wiener Mittagsblatt* (Vienna), May 15, 1933, p. 2, vs. "Der Spiessrutenlauf von Starhembergs Völkerbund," in: *Deutschösterreichische Tages-Zeitung* (Vienna), May 15, 1933, p. 1.

336 See Wiltshchegg: *Die Heimwehr*, p. 292.

337 See, for example, *Wiener Mittagsblatt* (Vienna), May 15, 1933, pp. 3–5.

338 See "Die Arbeiterpresse unter Vorzensur," in: *Arbeiter-Zeitung* (Vienna), March 26, 1933, pp. 1–2; "Der Schutzbund aufgelöst," in: *Arbeiter-Zeitung* (Vienna), April 1, 1933, p. 1.

with the justification that it was a particularly patriotic event.³³⁹ In contrast to Mussolini's "March on Rome" from 1922, it was therefore not about state power, which had long been in the hands of the conservative and increasingly authoritarian parties, but rather about a "relief of Vienna," a liberation of the capital from usurpers who were attempting to establish a model socialist region there. A farmer from Lower Austria who had taken part in the "Turks Deliverance Celebration" noted in his chronicle:

*Who would have thought it possible that the red heartland of Vienna would experience something like this. Ten years ago, no one would have been able to go to Vienna in his Home Guard jacket; only the reds ruled the streets of Vienna back then. But it was a beautiful omen of a different time when the peaceful citizen once again has his rights.*³⁴⁰

The battle against the "reds," who had ostensibly been working toward a proletarian revolution since the end of the monarchy and been occupying Vienna City Hall, was a driving force for the Austrian Home Guards from the outset. Alleged evidence of these dangers was provided by a passage from the program of the Social Democratic Workers' Party of Austria, which had been adopted in Linz in 1926 and clearly committed the party to the democratic system of government but in the event of a bourgeois "counterrevolution" did not exclude "breaking the bourgeoisie's resistance with the means of a dictatorship."³⁴¹ Opposition to the supposedly imminent "dictatorship of the proletariat" was offered in the form of a pledge by the Home Guards, which was declared during a leaders' conference in Korneuburg, Lower Austria, in May 1930. The so-called "Korneuburg Oath" (*Korneuburger*

339 See "Ausnahmen vom Aufmarschverbot statthaft," in: *Reichspost* (Vienna), May 14, 1933, p. 1.

340 Personal chronicle (vol. 1: 1906–1937, p. 100 [our trans.]) by Franz Bauer, a farmer from Neukirchen an der Wild in Lower Austria, source: Collection of Biographical Records (University of Vienna).

341 Cit. after "Das 'Linzener Programm' der Sozialdemokratischen Arbeiterpartei Österreichs, 1926," in: Klaus Berchtold (ed.): *Österreichische Parteiprogramme 1868–1966*, Vienna: Verlag für Geschichte und Politik 1967, pp. 247–264, here p. 253 [our trans.].

Eid) repudiated “Western democratic parliamentarism” and called for the establishment of an authoritarian corporative state, which was generally understood as an avowal of Fascism.³⁴²

The Homeland Protection was represented by its political party, the Homeland Block (*Heimatblock*), in the federal government formed by Engelbert Dollfuss in May 1932. Alongside Guido Jakoncig, who served as trade minister from the outset, Vienna’s Home Guard leader Emil Fey was appointed state secretary of public safety in fall 1932 and security minister on May 10, 1933, i.e., four days before the “Turks Deliverance Celebration.”

The federal chancellor’s Christian Social Party was increasingly authoritarian and just as right-wing as the peasant Rural Federation (*Bäuerlicher Landbund*), the third coalition partner, with the difference that the Homeland Block—and the **Homeland Protection in general**—openly advocated (Austro-) Fascism. “Away with parliament—a dictatorship is needed!” demanded Federal Leader Starhemberg on February 20, 1933, during a speech in Vienna’s Konzerthaus, claiming “that the ideas of Fascism alone are capable of saving the world.”³⁴³ The possibility for this radical political change opened up as early as the beginning of the following month, when the federal



Fig. 75: Propaganda poster by the Austrian Homeland Protection from 1933. The text reads: “Austria for the Austrians / this is what Starhemberg wants—this is what the Homeland Protection wants!” Source: Austrian National Library, PLA16311227.

Fig. 75, p. 189

342 Cit. after “Heimwehrkundgebungen am Sonntag,” in: *Reichspost* (Vienna), May 19, 1930, p. 2 [our trans.].

343 Cit. after “Fort mit dem Parlament!,” in: *Österreichische Heimatschutzzeitung* (Vienna), 2/8 (February 25, 1933), pp. 1–3, here pp. 2–3 [our trans.].

government used the resignation of the presidents of the National Council to abolish fundamental rights like freedom of the press and assembly using emergency decrees.³⁴⁴

III.1.3 With the support of Mussolini, Starhemberg suggested to the federal chancellor in April 1933 that a “Turks Deliverance Celebration” be held in the **gardens of Schönbrunn Palace** with a subsequent parade into the inner city of Vienna, namely as a public avowal of what he called “Austrofascism” and Dollfuss the “corporative state” (*Ständestaat*).³⁴⁵ The content of the speeches given by Fey, Starhemberg, and Dollfuss on May 14 was entirely in line with the political demands set out by the Home Guard leaders in Korneuburg in 1930. The chancellor denounced the “parliamentary machinery,” announced a “corporative state” and a “**Fatherland Front**,” which was founded just one week later as a unity party, and pledged “**allegiance upon allegiance**” to Starhemberg on the garden-side terrace of the palace building, in front of the eyes and ears of the thousands of Home Guard members who had traveled to Vienna for the rally, as well as the **cameras** and **microphones** of the journalists in attendance.³⁴⁶ It was no accident that the Homeland Protection subsequently emphasized that the Korneuburg Oath had become Austria’s state program at the “Turks Deliverance Celebration” on May 14, 1933.

Fig. 71, p. 174

Fig. 41, p. 112

III.2.2 · III.3.1

The Homeland Protection and the state authority had found common ground; the people’s state of the Home Guards, which had been unalterably established as the aim of our movement in the memorable Korneuburg Oath, had been achieved, even though its peaceful establishment still had to be safeguarded against threats from the right and left. In front of 40,000 patriotic men, who became witness to this triumph of their idea in the sun-drenched historic gardens of Schönbrunn Palace, Dollfuss and Starhemberg sealed the alliance of all vital powers

- 344 See the conference proceedings edited by the Austrian Parliamentary Administration: *Staats- und Verfassungskrise 1933*, Vienna: Böhlau 2014.
- 345 See Höbelt: *Die Heimwehren und die österreichische Politik 1927–1936*, pp. 271–272, and Ernst Rüdiger Starhemberg: *Die Erinnerungen*, Vienna/Munich: Amalthea 1991, pp. 137–138.
- 346 “Unser Weg ist der einzig richtige!,” in: *Wiener Mittagsblatt* (Vienna), May 15, 1933, pp. 4–5 [our trans., emphasis added].



Fig. 76: Ernst Rüdiger Starhemberg (at the front with bull pizzle), Engelbert Dollfuss (out of sight on his right), and Emil Fey (behind him) inspecting the Home Guard troops at the “Turks Deliverance Celebration” in the gardens of Schönbrunn Palace in Vienna on May 14, 1933, printed in *Österreichische Heimatschutzzeitung* (Vienna), 2/21 (May 27, 1933), supplement “Wehrfront im Bild,” p. 1. Source: Austrian National Library, 633589.

of the young Austria with a handshake. Homeland Protection planes crossed over the vast assembly and a march to the city and down the Ringstrasse finished off the solemn day that had proven that the rooster feather and green jacket had irrepressibly taken their place in Vienna.³⁴⁷

Fig. 76, p. 191

III.1.5

The official part of the rally began at 9:45 a.m., when Dollfuss, Starhemberg, and Fey **inspected and saluted** the troops standing in formation in the gardens of Schönbrunn Palace to the sound of the **national anthem**.³⁴⁸ The federal chancellor and the Home Guard leaders turned their attention pro forma to the front row, the assault company equipped with steel helmets. From a historical perspective, however, this inspection was based on the thorough “mustering” of mercenaries, as

347 *Heimatschutz in Österreich*, ed. Propagandastelle der Bundesführung des Österreichischen Heimatschutzes, Vienna: Zoller 1934, p. 23 [our trans.].

348 See a report by the Federal Police Headquarters in Vienna from May 15, 1933, in the Austrian State Archives (ÖStA/AdR, BKA-I, 148.459/33) and “Die Türkenbefreiungs-Feier des österreichischen Heimatschutzes am 14. Mai 1933 im Schloss Schönbrunn,” in: *Jahresschau 1933 der Bundespolizeidirektion in Wien. Eine Chronik im Laufbild*, 35 mm film, source: Filmarchiv Austria, JS 1933/8.

had been customary in Europe since the fifteenth century.³⁴⁹ Only those soldiers who were in good condition were enlisted. Louis XIV expanded this military examination in the seventeenth century by reviewing his moving guards from 1666. That means that the soldiers had to not only stand still in front of the French king but also maneuver with their weapons.³⁵⁰

In an Austrian “drill with weapons” (*Exercitium mit dem Feuegewehr*) from the period around 1700, fifty-six movements and maneuvers were listed, from “(1) Present arms” to “(10) Fire” and “(38) Fix bayonets” to “(56) Shoulder arms,” and a further hundred commands were recorded for the “evolutions,” i.e., maneuvers.³⁵¹ Over the course of the eighteenth century, especially in Prussia, a veritable “theater of war” developed, during which the troops were arranged in various geometric formations.³⁵² Besides the Baroque aesthetics, the rationale behind drills was to rehearse basic military virtues, namely hierarchical classification and physical discipline. That the drill was intended to be more than a practical preparation for war, however, is demonstrated by the Prussian drill regulations from 1743, for example, which state: “Foremost during a drill must be to tame a fellow and teach him a soldier’s air in order to banish the peasant in him [...]”³⁵³ The aim was a soldierly bearing, which shaped not only the body but also the morale. On the one hand, the soldier had to discharge his duty precisely in the platoon, even in life-threatening situations, and on the other be a model of decency in civilian settings.

III.1.4 **Napoleon** played an ambivalent role in the development of military parades. For one thing, he is symbolic of the militarization of the courtly festive culture customary throughout

349 See Walter Transfeldt: *Wort und Brauch in Heer und Flotte*, 9th ed., Stuttgart: Spemann 1986, p. 20.

350 See Michel Foucault: *Discipline and Punish. The Birth of the Prison*, trans. Alan Sheridan, New York: Vintage 1995 [French 1975], pp. 187–188.

351 Cit. after Oscar Teuber: *Die österreichische Armee von 1700 bis 1867*, vol. 1, Vienna: Berté & Czeiger 1895, p. 63 [our trans.].

352 See Hans-Peter Stein: *Symbole und Zeremoniell in deutschen Streitkräften vom 18. bis zum 20. Jahrhundert*, Herford/Bonn: Mittler 1984, pp. 130–135.

353 Cit. after Stein: *Symbole und Zeremoniell in deutschen Streitkräften vom 18. bis zum 20. Jahrhundert*, p. 190 [our trans.].

Europe in the late eighteenth century.³⁵⁴ He had his portrait painted in uniform as the emperor of the French and regularly held reviews, during which he inspected the soldiers' condition and equipment in detail.³⁵⁵ Napoleon also abided by this custom when he occupied Vienna with the French army in 1809, during which time he resided in Schönbrunn Palace for several months. The main reason why his parades in the palace's cour d'honneur are remembered is because Friedrich Staps used one of them as an opportunity for a—woefully unsuccessful—assassination attempt on October 12, 1809.³⁵⁶ The German commercial apprentice tried to approach the French emperor during his inspection of the troops in order to stab him with a kitchen knife that he had hidden in his greatcoat, but he was stopped by Napoleon's adjutants, arrested, and executed by a firing squad four days later.

Although Napoleon set great store by the traditional mustering of troops and performance of maneuvers, the French revolutionary soldiers actually led to a change in military training and tactics.³⁵⁷ Put simply, they were no longer mercenaries who had to be disciplined, but rather a people's army whose enthusiasm needed to be roused and exploited on the battlefield. The Home Guard parade after the "Turks Deliverance Celebration" in the gardens of Schönbrunn Palace, during which they marched to Schwarzenbergplatz in the inner city, expressed both military traditions. The troops advanced in lockstep "with ringing notes and flying colors," as had been commanded by the Prussian infantry regulations

- 354 See Jakob Vogel: *Nationen im Gleichschritt. Der Kult der 'Nation in Waffen' in Deutschland und Frankreich, 1871–1914*, Göttingen: Vandenhoeck & Ruprecht 1997, p. 31.
- 355 See, for example, Gustav von Schlabrendorf: *Anti-Napoleon*, Frankfurt a.M.: Eichborn 1991 [1804], pp. 152–153.
- 356 See Ernst Borkowsky: "Das Schönbrunner Attentat im Jahr 1809 nach unveröffentlichten Quellen," in: *Die Grenzboten* (Leipzig), 57/4 (1898), pp. 293–301, and Theodor Bitterau: "Friedrich Stepps und das Schönbrunner Attentat auf Napoleon I.," in: *Die Grenzboten* (Berlin), 69/3 (1910), pp. 212–220.
- 357 See Stein: *Symbole und Zeremoniell in deutschen Streitkräften vom 18. bis zum 20. Jahrhundert*, pp. 135–139.

of 1743, for example.³⁵⁸ In the original sense of the saying, the “ringing notes” set the pace of the march and the “flying colors” proclaimed its route. However, the participants in the Home Guard parade were not career soldiers as in the Austrian Armed Forces, which was a professional army until 1936, but volunteers from all over the country who were marching into the capital out of inner conviction.

III.1.3 The parade route from the cour d’honneur of Schönbrunn Palace up the Schlossallee, Mariahilfer Strasse, and Babenbergerstrasse to the Ringstrasse represented more than just the practical opportunity to march along wide boulevards from the southwest periphery into the city center. It was also along this route, some of whose streets had different names at the time, that the Habsburg monarchs had ridden from their **summer residence** to the Hofburg Palace.³⁵⁹ Although the Home Guards marched along an imperial path, they did not radiate sovereign power but embodied military discipline and regional popularity (*Volkstümlichkeit*). This difference becomes clear when the parade in the context of the “Turks Deliverance Celebration” is compared with the emperor’s advent in the imperial seat, which is said to have proceeded from Schönbrunn after the coronation of Leopold I in Frankfurt.

The then king of Bohemia and Hungary had departed Prague for Frankfurt am Main in late January 1658 with 430 men and 2,000 horses and arrived ceremoniously on March 19. Only four months later, the just eighteen-year-old Leopold was elected emperor of the Holy Roman Empire and finally crowned in Frankfurt cathedral on August 1.³⁶⁰ His return journey led him via Nuremberg, Munich, and Linz to Schönbrunn Palace, where Leopold is said to have spent the night

358 Cit. after Stein: *Symbole und Zeremoniell in deutschen Streitkräften vom 18. bis zum 20. Jahrhundert*, p. 200 [our trans.].

359 See Richard Kurdiovsky: *Die Gärten von Schönbrunn. Ein Spaziergang durch einen der bedeutendsten Barockgärten Europas*, St. Pölten: Residenz 2005, p. 10.

360 See Rotraut Miller: “Die Hofreisen Kaiser Leopolds I.,” in: *Mitteilungen des Instituts für Österreichische Geschichtsforschung*, 75/1–2 (1967), pp. 66–103, here pp. 91–99.

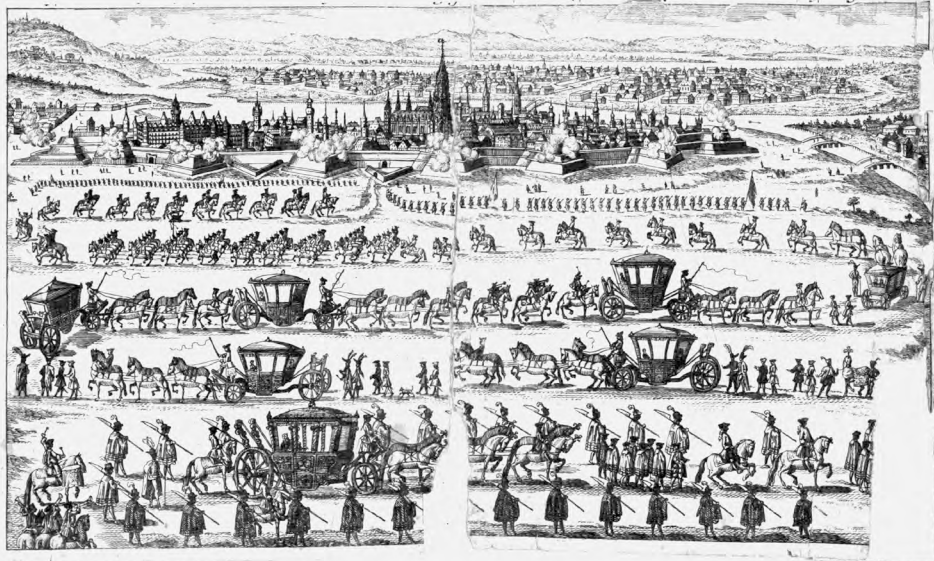

Fig. 77: Contemporary copperplate engraving showing the return of the Holy Roman Emperor Leopold I to Vienna on October 1, 1658, after his coronation in Frankfurt am Main. Source: Wien Museum, 199057.

on September 30.³⁶¹ From there, the emperor entered Vienna with his entourage on October 1, was welcomed with a kiss on the hand by a political delegation on Getreidemarkt, at the end of what is now the Mariahilfer Strasse, and then rode on to Stubentor, the eastern city gate, to the thunder of cannon fire. Here the mayor symbolically handed the monarch the keys to the city and cleared the way to St. Stephen's Cathedral, a route that led down the Wollzeile under a sky of gold brocade. In the cathedral, the Christian hymn of praise *Te Deum laudamus* was sung, whereupon all the bells of the city pealed and once again the cannons roared. The emperor subsequently rode under three triumphal arches, which had been constructed in his honor, along the Graben, where wine poured from the fountains for the people, and along the Kohlmarkt to what is now Michaelerplatz. When he arrived at the Hofburg Palace,

361 See Elisabeth Hassmann: *Von Katterburg zu Schönbrunn. Die Geschichte Schönbrunn's bis Kaiser Leopold I.*, Vienna: Böhlau 2004, pp. 461–462.



Fig. 78: Engraving by Jan Thomas from 1667 showing Leopold I in theatrical costume. Source: Kunsthistorisches Museum (Vienna), GG 9135.

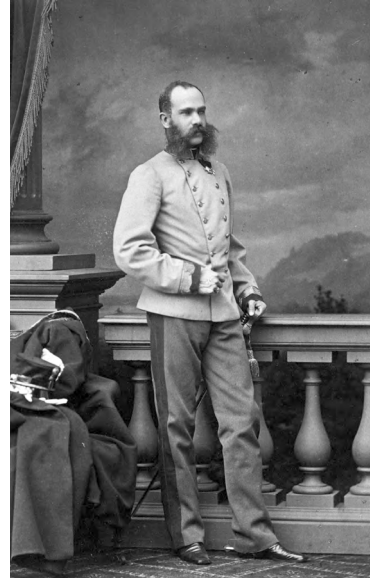

Fig. 79: Francis Joseph I in uniform as Colonel-in-Chief of the Kaiserjäger (1868). Source: Austrian National Library, Pf 19000 E 35 Var.

the cannons were fired for the third time to symbolize the end of the emperor's advent in the imperial seat.³⁶²

Fig. 77, p. 195

There is a **copperplate engraving** of Leopold's return to Vienna on October 1, 1658, which is typical of the visual representation of royal advents in cities in the seventeenth and eighteenth centuries. Whereas such events had previously been illustrated as series of pictures, around 1600 stand-alone depictions emerged, which portrayed the procession in a meandering line against the backdrop of the city.³⁶³ The social rank of the participants progressively increased, in this

362 On the description of the advent, see Miller: "Die Hofreisen Kaiser Leopolds I.," pp. 90–91, and Andrea Sommer-Mathis: "'...ma il Papa rispose, che il Re de' Romani a Roma era lui.' Frühneuzeitliche Krönungsfestlichkeiten am Kaiser- und Papsthof," in: Richard Bösel, Grete Klingenstein, Alexander Koller (eds.): *Kaiserhof – Papsthof. 16.–18. Jahrhundert*, Vienna: Österreichische Akademie der Wissenschaften 2006, pp. 251–284, here p. 283.

363 See Harriet Rudolph: "Die visuelle Kultur des Reiches. Kaiserliche Einzüge im Medium der Druckgraphik," in: Heinz Schilling, Werner Heun, →



Fig. 80: Austrian Home Guard troops marching from Schönbrunn Palace to Schwarzenbergplatz in Vienna on May 14, 1933, here along Mariahilfer Strasse near the Technical Museum. At the head of the paramilitary parade: Ernst Rüdiger Starhemberg (in the center) with Emil Fey (on his right) and Richard Steidle (on his left). Source: Austrian National Library, H 2012.

Fig. 78, p. 196

Fig. 79, p. 196

Fig. 40, p. 111

Fig. 80, p. 197

specific case from the head of the procession at the Stubentor, with the emperor's dress coach only appearing at the lower edge of the engraving. During this ceremonious advent in the city, the monarch did not present himself as a commander in chief riding ahead of his troops, but as a representative of god on earth, whose arrival (Latin *adventus*) had to be prepared and announced by a long procession to make the people aware of their ruler's majesty. The emperor was the main actor in this sensory spectacle, which is why it is not an anomaly that Leopold later had his portrait painted in **theatrical costume**. That would have been inconceivable for Emperor Francis Joseph I in the nineteenth century, who almost always wears **military uniform** in official portraits.

The Austrian Homeland Protection staged a theatrical "Turks Deliverance Celebration" in the gardens of Schönbrunn Palace, during which the speakers assumed the **sovereign position** on the garden terrace of the palace building, the central point of intersection in the star-shaped site. However, the leaders, with Ernst Rüdiger Starhemberg showing the way, subsequently constituted the **vanguard of the Home Guard troops** and marched toward the inner city in steel helmets and with bull piddles in hand. After roughly one and a half

→ Jutta Götzmann (eds.): *Heiliges Römisches Reich Deutscher Nation 962–1806. Altes Reich und neue Staaten 1495–1806*, vol. 2: Essays, Dresden: Sandstein 2006, pp. 231–241.

II.15 &
Fig. 34, p. 93

hours, they were the first to arrive at **Schwarzenbergplatz**, where they stood in a line to review the remaining parade. The Home Guard members lowered their standards as they marched past and turned their heads to face their leaders, who saluted to confirm that they had passed the examination.

2.2 Camera: Bell & Howell 2709



place	Mariahilfer Strasse 124
moment	Filming of Home Guard parade
space	2 km 530 m from the start
time	49 min before the end

- II.10 There are several film recordings of the “**Turks Deliverance Celebration**” (*Türkenbefreiungsfeier*), which was held in Vienna by the Austrian Homeland Protection (*Heimatschutz*) on May 14, 1933. They were included in the *Jahresschau 1933*, an annual newsreel produced by the Federal Police Headquarters in Vienna that is preserved at the Filmarchiv Austria, in the form of two independent reports, one silent and one sound film, both of them in black and white.³⁶⁴ The silent film, which was evidently produced by police employees, is about five minutes long and shows the Home Guard (*Heimwehr*) members’ arrival
- III.1.3 by train, the rally in the **gardens of Schönbrunn Palace**, and the
- II.15 parade into the city center to **Schwarzenbergplatz**. According to the introductory intertitle, the slightly longer sound film is part of a *Fox Tönende Wochenschau* newsreel, which not only contains audiovisual recordings of the celebration in Schönbrunn but also visualizes and audibilizes the protests against the subsequent Home Guard parade: National Socialists sing the *Deutschlandlied* and whistle and boo at the marching
- III.1.5 Homeland Protectors.

From the perspective of film technique, the recordings of the upper Mariahilfer Strasse are interesting because the camera travels ahead of the parade, panning to the protestors on the sidewalk and then back to the Homeland Protectors.

364 “Die Türkenbefreiungs-Feier des österreichischen Heimatschutzes am 14. Mai 1933 im Schloss Schönbrunn” and “Die Türkenbefreiungsfeier des österreichischen Heimatschutzes in Wien,” in: *Jahresschau 1933 der Bundespolizeidirektion in Wien. Eine Chronik im Laufbild*, 35 mm film, source: Filmarchiv Austria, JS 1933/8. See Barbara Zuber: *Die “Polizeijahresschauen” 1928–1938. Eine filmische Quelle zur Wiener Polizeigeschichte der Zwischenkriegszeit*, University of Vienna: PhD diss. 1996, pp. 586–619.



Fig. 81: Austrian Home Guard troops marching from Schönbrunn Palace to Schwarzenbergplatz in Vienna on May 14, 1933, here at around noon on the upper Mariahilfer Strasse near the Westbahnhof train station. At the head: Ernst Rüdiger Starhemberg (in the center saluting) with Emil Fey (on his right) and Richard Steidle (on his left). On the right edge of the picture: a cameraman filming the paramilitary parade. Source: Austrian National Library, 66.287 B.

Fig. 81, p. 200

A **photograph** taken around noon near Vienna's Westbahnhof station³⁶⁵ shows the head of the parade at the beginning of this film sequence. On the right edge of the picture, a cameraman is visible on the roof of a car, wearing a coat and suit complete with necktie, his hair tousled by the motion of the vehicle. In this moment he appears to be the focus of everyone's attention: the gaze of many spectators, even of the Home Guard leader Richard Steidle, who is marching alongside **Ernst Rüdiger Starhemberg** and Emil Fey at the forefront of the parade, is aimed at him and his camera.

III.1.1

365 A clock above the sidewalk shows 12:11 p.m.; on the right is Oscar Melnik's chinaware shop, which was located at Mariahilfer Strasse 124; see *Wiener Adressbuch. Lehmanns Wohnungsanzeiger 1933*, vol. 1, Vienna: Österreichische Anzeigen-Gesellschaft 1933, p. 1036.

The vehicle is too small to be a professional recording van and also does not bear the name of a production company. Instead, it looks as though a stand had been affixed onto an ordinary sedan car in order for the camera, its operator, and equipment to be able to sit on the roof. It is highly likely that it was this cameraman who took the recordings contained in the *Jahresschau 1933* by the Viennese police. As mentioned above, there they feature the intertitle of the *Fox Tönende Wochenschau*, which had been the German-language version of the American *Fox Movietone News* since 1929. According to contemporary film magazines, the following week it was not only Fox that released “pictures of the Turks Deliverance Celebration in Vienna,” but also Paramount in their newsreel.³⁶⁶ Furthermore, several photographic and filmic documents reveal that the Viennese Selenophon Licht- und Tonbild GmbH was present in the gardens of Schönbrunn with their **recording van**. However, the sound film they recorded, which might have been published in the Austrian *Engel-Woche*, has not survived. Selenophon also produced the “patriotic newsreel” *Österreich in Bild und Ton* (“Austria in Image and Sound”) on commission from the Federal Chancellery, which played in movie theaters from June 1933 but which did not contain a piece on the “Turks Deliverance Celebration” of May 14.³⁶⁷

Fig. 56, p. 143

The cameraman was presumably a freelancer and sold his recordings to film companies like Fox or Paramount. Further evidence of this is the camera, which can be seen in the **photograph**. Although the model cannot be identified with complete certainty even after looking at the picture under a magnifying glass, the metal frame, the lens turret, the double-compartment film magazine, and the side viewfinder clearly point to the standard model by the American manufacturer Bell & Howell, with the type number 2709.³⁶⁸ The camera is mounted

Fig. 81, p. 200

366 See, for example, *Österreichische Film-Zeitung* (Vienna), 7/20 (May 20, 1933), p. 6 [our trans.].

367 See Michael Achenbach and Karin Moser: “Filmografie – Österreich in Bild und Ton,” in: Michael Achenbach and Karin Moser (eds.): *Österreich in Bild und Ton. Die Filmwochenschau des austrofaschistischen Ständestaates*, Vienna: Filmarchiv Austria 2002, pp. 397–556.

368 I owe special thanks to Martin Reinhart for his assistance in identifying the camera model.

on a tripod and was obviously operated using a synchronous motor, which is attached on the right-hand side. This uniform drive made it possible to record not only twenty-four frames per second, but also synchronous optical sound, the equipment for which must have been located inside the car. In any case, the film preserved at the Filmarchiv Austria contains audio recorded on a variable-density track.³⁶⁹ That means that the film reel, which is thirty-five millimeters wide and perforated at the edges, has photographic images on the right and the corresponding soundtrack—with uniform area but variable density—

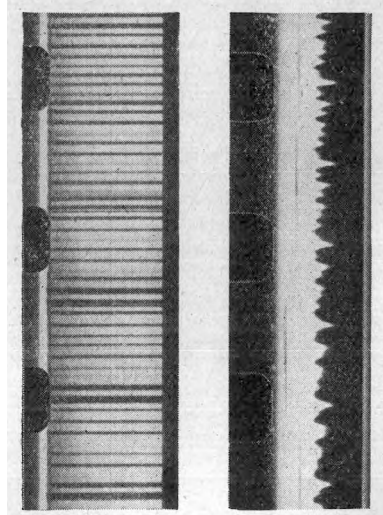

Fig. 82: Two methods for recording optical sound on film: in variable-density format (on the left) and in variable-area format (on the right), printed in *Radio-Amateur* (Vienna), 9/2 (February 1932), p. 121. Source: Vienna University Library, I-458300.

Fig. 82, p. 202

next to it on the left. For this reason, this **sound-recording technology** came to be known as variable-density recording systems, in contrast to variable-area systems in which the density of the soundtrack remains the same but its width changes, giving rise to a track with a jagged appearance.

The film camera documented in the photograph was not state of the art around 1933. At this time, much lighter 35 mm cameras were available, which had been specially developed for newsreels and outdoor recordings, e.g., the spring-driven, just over three-kilo Eyemo by Bell & Howell, which had been on the market since 1925. Despite dating back to 1912 and—with its film magazine, lenses, and additional motor—weighing some twenty kilos, the 2709 model was known for its reliability

369 See the corresponding data sheet in the Filmarchiv Austria, film no. 5860/1, sequel 2.

and longevity.³⁷⁰ For this cameraman, it may have been more cost-effective to upgrade the older, heavy camera with a motor and sound system than to buy the latest model used by the leading newsreel producers. Moreover, the Bell & Howell 2709 was a complete studio camera and hence more versatile than a device specially developed for mobile recordings like the aforementioned Eyemo, an upgraded version of which was released with an electric drive motor in 1932.³⁷¹

Founded in Chicago in 1907, the Bell & Howell company carried the 2709 as its “standard camera,” and in the course of a decade the model did in fact become established as the standard camera in American film studios.³⁷² However, this description does not refer to its commercial success, but rather the 35 mm format it used, the standardization of which as the “standard film” size was in no small part due to this camera and other equipment made by Bell & Howell. The first roll films produced by George Eastman for his Kodak cameras in 1888 were almost seventy millimeters wide. Edison had the 70 mm film halved and used the 35 mm format for his Kinetoscope, a motion picture exhibition device with a peephole for an individual viewer patented in 1893. However, the wide range of projectors in use around 1900 meant that film widths varied greatly. Donald J. Bell’s experience as a projectionist in Chicago made him familiar with the disadvantages of the various formats and perforations.³⁷³ Even in the instances when a film reel fitted the projector available for the respective screening—the exception rather than the rule—it was to be expected that the reel would repeatedly fall out of the film advance mechanism while cranking. The result in most cases was not the impression of fluid movement, which arises with a

370 The seven-and-a-quarter-kilo camera alone cost US\$1,000, see Héctor Mario Raimondo-Souto: *Motion Picture Photography. A History 1891–1960*, Jefferson: McFarland 2006, pp. 27–29.

371 See Jack Fay Robinson: *Bell & Howell Company. A 75-Year History*, Chicago: Bell & Howell 1982, pp. 25 and 48–49.

372 See Kristin Thompson: “Initial Standardization of the Basic Technology,” in: David Bordwell, Janet Staiger, Kristin Thompson (eds.): *The Classical Hollywood Cinema. Film Style and Mode of Production to 1960*, London: Routledge 2006 [1985], pp. 262–280, here p. 268.

373 On the following, see Robinson: *Bell & Howell Company*, pp. 15–25.



Fig. 83: A Bell & Howell 2709 35 mm movie camera from 1922 with a double-compartment film magazine, lens turret, and side viewfinder, photographed by Adam J. Wilt in 2012. Source: adamwilt.com.

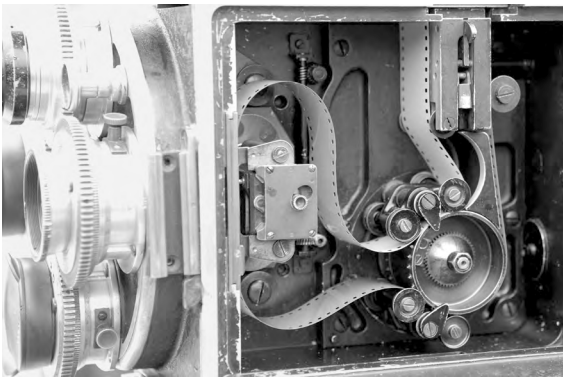

Fig. 84: Mechanics of a Bell & Howell 2709 35 mm movie camera from 1922, photographed by Adam J. Wilt in 2012. Source: adamwilt.com.

constant speed of at least sixteen frames per second. Instead, the projected events ran at an irregular speed; the pictures flickered and jumped around on the screen.

In well-planned events, apparatuses like the Cinématographe by the Lumière brothers, the Bioscop by the Skladanowsky brothers, or Edison's Vitascope, which were launched in the mid-1890s, may have lived up to the promise of their names and indeed presented life as movement, as conceived by modern biology in the nineteenth century.³⁷⁴ In everyday film screenings, however, this illusion could only be enjoyed by those audience members whose concept of life admitted more phenomena than met their eyes. Donald Bell was aware of the problem due to his work as a projectionist, and the mechanical engineer Albert S. Howell, whom he met in a film

374 See Michel Foucault: *The Order of Things. An Archaeology of the Human Sciences*, London/New York: Routledge 2002 [French 1966], pp. 235–329, esp. pp. 251–252 and 303.

workshop, presented a solution with a series of technical innovations that led to the first products of their joint company, Bell & Howell: a contraption to frame images—known as a “rotary framer”—for the 35 mm film projector Kinodrome; a perforator to standardize the perforations in 35 mm film; a camera that transported 35 mm film over fixed pilot pins; and a printer that could copy 35 mm film with the same transport mechanism.³⁷⁵ In other words, the newly founded company focused entirely on the 35 mm format and its technical solutions ensured that film would pass through recording and projection devices reliably and at a uniform speed.

The first camera produced by Bell & Howell was already equipped with the innovative film movement mechanism for stable exposure, but it was still clad in wood and leather. This was followed in 1912 by the 2709 model, whose **mechanics and casing**—in contrast to all movie cameras developed until that point—were made entirely of metal. Two magazines were mounted on the camera, one for unexposed and one for exposed film. Another feature of the camera was the turret for four lenses, which not only simplified the cameraperson’s job, but was also essential for focusing. In order to get a subject in focus, the camera had to be shifted from right to left on a metal base attached to a tripod and the lens turret turned 180 degrees. Then the cameraperson could adjust the lens without exposing the film. It was also the only opportunity to see precisely what would later be filmed, because the viewfinder mounted on the left side of the camera showed the respective subject from a perspective laterally offset from the recording lens—a so-called “parallax error,” which had not yet been corrected at that time. Also worth mentioning is the fact that the hand crank in the 2709 model was supported by ball bearings, which made the drive easier and also added to the image quality. Bell & Howell’s standard camera would be manufactured until 1958.³⁷⁶

Fig. 83 &
Fig. 84, p. 204

- 375 See Robinson: *Bell & Howell Company*, pp. 24–25 and 167.
376 See Raimondo-Souto: *Motion Picture Photography*, pp. 27–29; Thompson: “Initial Standardization of the Basic Technology,” pp. 267–268; Robinson: *Bell & Howell Company*, p. 25.

City map of Vienna (1933 © Freytag & Berndt)

place	Mariahilfer Strasse 124
moment	Filming of Home Guard parade
space	2 km 530 m from the start
time	49 min before the end

mediations

- How to Use Reason: Sovereign Signs
- How to Capture Life: Examining Gazes
- How to Speak Up: Governed Transmissions

Fig. 85: Screenshot of the Topology module of the website campusmedius.net (desktop version 2.0/2021) showing the abstract of the mediator



How to Capture Life: Examining Gazes

CAMERA

Bell & Howell 2709

There are several film recordings of the "Turks Deliverance Celebration" in Vienna on May 14, 1933. The sound films derive from the German edition of *Fox Movietone News* and were taken with a Bell & Howell 35 mm camera—an upgraded version of the model 2709.

READ MORE

“Bell & Howell 2709” in the mediation “How to Capture Life: Examining Gazes”
(text: Simon Ganahl, code: Andreas Krimbacher, design: Susanne Kiesenhofer).

III.2.4

Fig. 81, p. 200

The film camera photographed at the beginning of the upper Mariahilfer Strasse in Vienna at noon on May 14, 1933, was in all probability the 2709-B1 model by Bell & Howell. This version could record up to twenty-six frames per second and was not sound insulated.³⁷⁷ The operating sound of the camera, comparable to a sewing machine, only became a problem with the general **transition to sound film** in the late 1920s. While the film studios had developed sound-absorbing cases known as “blimps,” the manufacturers were working on making quieter cameras. With the models NC (1932) and BNC (1934), Mitchell responded better to this technological challenge than Bell & Howell, who concentrated more and more on the amateur film business with cameras and projectors for the 16 mm format.³⁷⁸ However, sound film necessitated not only a reduction in camera sounds, but also a constant recording speed of twenty-four frames per second in order to synchronize sound and image. There had been an electric drive motor for the 2709 model since 1919, which was mounted on the back and considerably smaller than the solid synchronous motor used by the cameraman at the “Turks Deliverance Celebration.” In the **photograph**, he is grasping it with his right hand, presumably to pan the camera back to the parade, though deliberate focusing would not have been possible. Whether the recordings could be used would only become clear once the film had been developed.

In this case, despite having filmed from the roof of a moving sedan, the cameraman appears to have captured his subject well enough to present the recordings in the subsequent edition of the *Fox Tönende Wochenschau*. They captured the movement of the parade in twenty-four frames per second (and in a soundtrack recorded using variable-density technology) on a 35 mm film. His “fondest hope” for the movie industry had always been standardization, wrote Donald Bell in a letter to the magazine *International Photographer* in 1930.³⁷⁹ In the

377 See *Bell & Howell Standard Professional 35mm Cameras Specifications*, Chicago: Bell & Howell 1943, p. 1, source: Filmarchiv Austria.

378 See Raimondo-Souto: *Motion Picture Photography*, pp. 142–145; Robinson: *Bell & Howell Company*, pp. 45–47.

379 Donald J. Bell: “A Letter from Donald Bell,” in: *International Photographer* (Hollywood), 2/1 (February 1930), pp. 18–21, here p. 19.

III.2.1

three decades since he had left his job as a projectionist in Chicago, the 35 mm format, promoted by the company he had founded with Albert Howell, had become established around the world. From a formal perspective, there was now barely any difference between the pictures on the professional film market, and neither during recording nor projection was it possible to manually influence how quickly the film reel passed through the equipment. This is why on May 14, 1933, not only the Austrian Home Guard members, but also the pictures that document their “**march on Vienna,**” moved in lockstep. Thus the film’s format mirrored the uniformity of its subject.

2.3 Montage: Perceptual Gymnastics



place	Engelmann Arena
moment	Nazi rally
space	4 km 958 m from the start
time	16 h 30 min before the end

Fig. 86, p. 211

The NSDAP's Reich Propaganda Headquarters (*Reichspropagandaleitung*) in Berlin published the *N.S. Ton-Bild-Bericht Nr. 2* ("N.S. Sound Image Report No. 2") in summer 1933, which has been preserved in the Film Archive of the German Federal Archives.³⁸⁰ The fourth and final piece in the 530-meter-long sound film, which when played at a speed of twenty-four frames per second corresponds to about twenty minutes, has the title "**Austria!**" (*Österreich!*) and begins with a panel of text about the "campaign of destruction" being conducted "against National Socialism" by Austrian Federal Chancellor Engelbert Dollfuss. This is followed by images of headlines in the German Nazi newspapers *Der Angriff* and *Völkischer Beobachter* about a "growing fermentation" and "Christian Social conspiracy" in Austria. The visuals are accompanied by a male voice-over commenting: "In Austria the reaction is fighting its last-ditch battle against National Socialism, the only guarantor of the Greater German idea. On the occasion of a celebration in memory of Vienna's liberation from the Turks, Federal Chancellor Dr. Dollfuss speaks to the assembled Home Guard [*Heimwehr*] members." The next sequence comes from a piece in the *Fox Tönende Wochenschau* newsreel about the "**Turks Deliverance Celebration**" (*Türkenbefreiungsfeier*) hosted by the Austrian Homeland Protection (*Heimatschutz*) on Sunday, May 14, 1933, in the **gardens of Schönbrunn Palace**.³⁸¹

380 See *N.S. Ton-Bild-Bericht Nr. 2*, 35 mm film, Berlin: NSDAP 1933, source: Film Archive of the Federal Archives (Berlin), K 20317-2. The following translations of textual or spoken passages in this film are our own.

381 See "Die Türkenbefreiungsfeier des österreichischen Heimatschutzes in Wien," in: *Jahresschau 1933 der Bundespolizeidirektion in Wien. Eine Chronik im Laufbild*, 35 mm film, source: Filmarchiv Austria, JS 1933/8.



Fig. 86: Intertitle of the final piece “Austria!” in the *N.S. Ton-Bild-Bericht Nr. 2*, a 35 mm sound film published by the NSDAP’s Reich Propaganda Headquarters in Berlin in summer 1933, here after a VHS copy. Source: Film Archive of the Federal Archives (Berlin), K 172392-1.



Fig. 87: Still from the piece “Austria!” in the *N.S. Ton-Bild-Bericht Nr. 2*, a 35 mm sound film published by the NSDAP’s Reich Propaganda Headquarters in Berlin in summer 1933, here after a VHS copy: Hans Frank (second from right) addresses Alfred Eduard Frauenfeld (on his left) in the foyer of the Adolf Hitler House at Hirschengasse 25 in Vienna on the afternoon of May 13, 1933. Source: Film Archive of the Federal Archives (Berlin), K 172392-1.

In it Dollfuss says that “foreign spirit and foreign ideas” had “infected” the people and wreaked “evil havoc.”

- III.1.1 While the Home Guard leader **Ernst Rüdiger Starhemberg** is visible on the garden terrace of Schönbrunn Palace, the commentator claims: “At the same time, this Austrian people received the German ministers Kerrl and Frank in Vienna.” In reality, Bavarian Justice Minister Hans Frank and his Prussian counterpart Hanns Kerrl had landed at **Aspern**
- II.1 **airfield** in Vienna the previous day, at shortly after 2 p.m. on Saturday, May 13, 1933, and then driven in a convoy to the
- II.4 **Adolf Hitler House** in the city center. The subsequent recordings of cheering National Socialists were presumably made when the German politicians arrived at the NSDAP’s Viennese headquarters at Hirschengasse 25. There, in the **foyer of the Adolf Hitler House**, Frank thanks the gau administrator (*Gauleiter*) in charge, Alfred Eduard Frauenfeld, “for the kind reception” in Vienna: it was a “tremendous joy” to be able to emphasize in the “most German part of the East,” where

Fig. 87, p. 211



Fig. 88: Still from the piece “Austria!” in the *N.S. Ton-Bild-Bericht Nr. 2*, a 35 mm sound film published by the NSDAP’s Reich Propaganda Headquarters in Berlin in summer 1933, here after a VHS copy: storm troopers marching past Adolf Hitler and Ernst Röhm. Source: Film Archive of the Federal Archives (Berlin), K 172392-1.



Fig. 89: Still from the piece “Austria!” in the *N.S. Ton-Bild-Bericht Nr. 2*, a 35 mm sound film published by the NSDAP’s Reich Propaganda Headquarters in Berlin in summer 1933, here after a VHS copy: a Nazi rally in the Engelmann Arena in Vienna on May 1, 1933. Source: Film Archive of the Federal Archives (Berlin), K 172392-1.

Hitler’s “life struggle as a simple manual laborer” had begun, that the führer was proud of his homeland, which stood “by him and his movement, by the idea of peace among peoples, by the idea of national prosperity, by the idea of the freedom and purity of national life.”

- III.1.5 Nazi supporters can then be seen and heard singing the *Deutschlandlied* near the Technical Museum in Vienna. They are violently pushed to the edge of the Mariahilfe Strasse by mounted police and with batons and bayonets to clear the
- III.2.1 way for the **Home Guard parade**, which ran from Schönbrunn
- II.15 Palace all the way to **Schwarzenbergplatz**. These scenes took place after the “Turks Deliverance Celebration” on Sunday, May 14, and were also captured in the piece in the *Fox Tönende Wochenschau*. Then, while the Home Guard members are marching down the upper Mariahilfer Strasse in lockstep, the male voice-over comments: “The path of suppression and prohibition is dangerous when one has the majority of the people against one and as an opponent a movement whose

Fig. 88, p. 212

inner strength overruns everything that stands in its way.” The image changes in the middle of the sentence to show **storm troopers with swastika flags** entering the frame from the right-hand side, marching in a strict and orderly fashion past Hitler who reviews the parade by clicking together the heels of his boots and raising his arm.

Fig. 89, p. 212

II.7

The final sequence of the sound film shows a **Nazi rally in the Engelmann Arena** in Vienna. Even though it is not stated explicitly, the context implies that it was the National Socialist **“Turks Deliverance Celebration”** on the evening of Saturday, May 13, 1933. In fact, however, these recordings were made almost two weeks earlier, on May 1, when the NSDAP was celebrating the “Day of National Work” there.³⁸² A band is playing the military march *Preussens Gloria*, which was composed in 1871 by Johann Gottfried Piefke. Afterward the Viennese gau administrator Frauenfeld speaks: “But we, my German national comrades, we who have fought this battle with pleasure and devotion, we will have crowned this battle with success, with victory! We Germans here of the Eastern March [*Ostmark*], we will have found our way home to the Holy Third German Reich!” Accompanied by the band, the crowd then starts singing the NSDAP’s party anthem, the *Horst-Wessel-Lied*, with which the *N.S. Ton-Bild-Bericht Nr. 2* fades out.

On several levels this propaganda film depicts falsehoods. On the one hand in terms of its content, which juxtaposes the Christian Social “suppression” in Austria with a National Socialist “freedom.” Even though the “Turks Deliverance Celebration” in Vienna on May 14, 1933, clearly showed that the Austrian federal government was on its way to an authoritarian “corporative state” (*Ständestaat*, Dollfuß) or to “Austrofascism” (Starhemberg), the Nazi regime in Germany reacted far more brutally to its political opponents.³⁸³ Besides this distortion of facts, the *N.S. Ton-Bild-Bericht Nr. 2* also manipulates actual events in temporal terms. Because in truth, Hans Frank

382 See the film “NSDAP-Kundgebung zum 1. Mai 1933 in der Wiener Engelmann-Arena,” in: Hannes Leidinger and Karin Moser (eds.): *Österreich Box 2: 1918–1938. Zwischen den Weltkriegen*, DVD, Vienna: Filmarchiv Austria 2008.

383 “Substantially and structurally profound differences to National Socialism existed with regard to the extent and intensity of the terror and repression, as well as concerning the racist and imperialist direction of the policies,” →

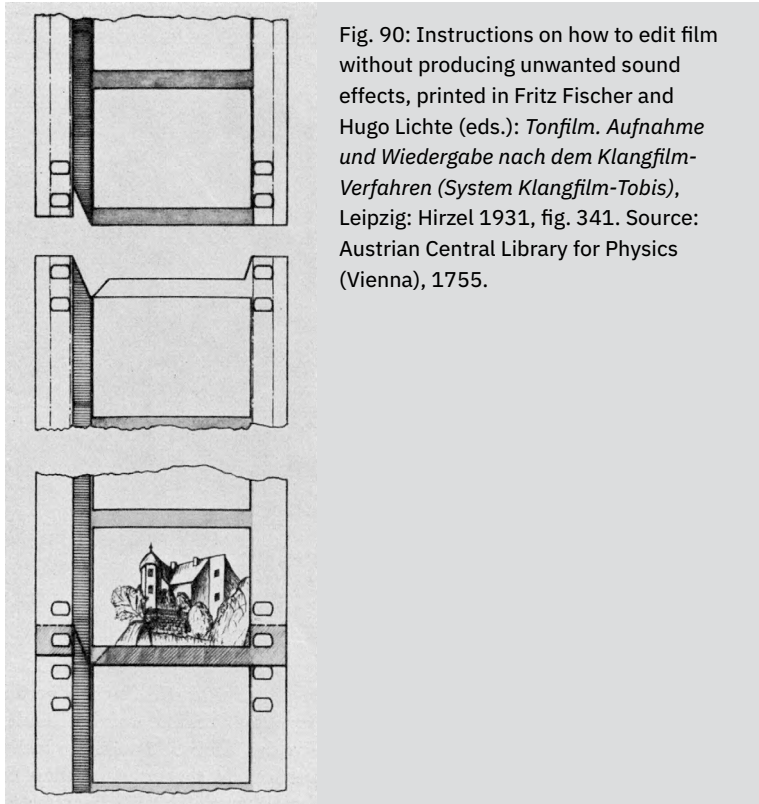

and Hanns Kerrl did not arrive in Vienna while the Austrian Homeland Protection was holding the “Turks Deliverance Celebration” in Schönbrunn, but the day before. Moreover, the final recordings from the Engelmann Arena show the rally for the “Day of National Work” from May 1, 1933, and not, as the context implies, the National Socialist “Turks Deliverance Celebration,” which took place there on May 13. In other words, the film portrays the events untruthfully insofar as its audiovisual representation contradicts numerous other documents (news-paper articles, police reports, photographs, and newsreels).

In order to produce this impression of reality, sequences from the *Fox Tönende Wochenschau* were combined with recordings that had presumably been made by the NSDAP’s

→ writes Emmerich Tálos of the Austrofascist regime, in: Emmerich Tálos and Wolfgang Neugebauer (eds.): *Austrofascismus. Politik – Ökonomie – Kultur. 1933–1938*, 5th ed., Vienna: LIT 2005, p. 414 [our trans.].

Austrian Film Office (*Landesfilmstelle*). The existing soundtracks in variable-density format were replaced in part by commentary by a male narrator on a variable-area track, which—like the introductory text panel—explains what the viewers can see in the images. This merging technique is known as film editing or montage and resembles a **crafting exercise**. In this specific case, the film strips from the Fox newsreel and the NSDAP recordings not only had to be cut and stuck back together, but in places they also had to be post-dubbed. The result was a patchwork of photographic images and **optical sound recordings**, which only reemerged as an—at least physically—coherent 35 mm film after the copying process.

Fig. 90, p. 214

Fig. 82, p. 202

II.8 &
Fig. 26, p. 73

However, around 1930, editing was more than merely a stage of film production. Rather, the term “montage” implied the film art by Russian directors of the 1920s.³⁸⁴ In the middle of the chronotope, the time-space, with which the report on Austria in the *N.S. Ton-Bild-Bericht Nr. 2* is concerned, two exemplary works of Russian film could be seen: in Vienna’s **Friedensbrücken Kino**, a movie theater at Klosterneuburger Strasse 33, the films *Panzerkreuzer Potemkin* (*Battleship Potemkin*) by Sergei Eisenstein and *Turksib* by Viktor Turin were screened from 11 p.m. on Saturday, May 13, 1933.³⁸⁵ Eisenstein in particular was both a practitioner and theorist of montage.³⁸⁶ If one follows his development from the theater to the cinema, it becomes clear that he had nothing less than an exact representation of reality in mind. The aim of his montage technique was to have as great an impact as possible on the audience. From a purely technical point of view, the montage ideal is depicted in the sequence from the feature film *Hitchcock* (2012) by Sacha Gervasi in which the premiere of the thriller *Psycho* is shown. Played by Anthony Hopkins, the director Alfred Hitchcock is initially in the projection booth as he watches the audience react tensely to the action on screen. Then during the most famous scene of *Psycho*, in

384 See Bernd Stiegler: *Der montierte Mensch. Eine Figur der Moderne*, Paderborn: Fink 2016, pp. 131–178.

385 See *Die Rote Fahne* (Vienna), May 13, 1933, p. 4.

386 See Oksana Bulgakowa: “Montagebilder bei Sergej Eisenstein,” in: Hans Beller (ed.): *Handbuch der Montage*, 4th ed., Munich: TR-Verlagsunion 2002, pp. 49–77.

which Marion Crane (Janet Leigh) is stabbed to death under the shower, Hitchcock is shown in the movie theater's foyer and, in time with the film's soundtrack, conducts the viewers as they flinch and scream to the same rhythm as his edits.³⁸⁷

Fig. 91, p. 217

The notion of the director being a conductor of the actors and audience alike is not only applicable to Hitchcock, but also to Eisenstein and his teacher Vsevolod Meyerhold, who became a pioneer of **Constructivist theater** after the Russian Revolution of 1917. For Meyerhold, the director was the author of a theatrical staging and the audience its active participant. He viewed movement as the central aspect of theater, vehemently advocating stylized and rejecting realistic forms of representation. Around 1920 he developed a system for training actors that he called biomechanics and that was based on principles of Taylorism and reflexology. Meyerhold adopted methods of “scientific management” from the American engineer Frederick Winslow Taylor in order to increase the efficiency of body movements (e.g., through rhythmization). The Russian school of objective psychology, established by Vladimir Bekhterev and Ivan Pavlov, influenced his biomechanics insofar as emotional states were supposed to be evoked reflexively by physical stimuli. For this purpose, the director commanded his actors to rehearse exercises that he put together from very diverse fields. He adapted combinations of movements from modern gymnastics, boxing training, military drills, circus art, and theatrical traditions like Japanese Kabuki or the Italian *Commedia dell'Arte*.³⁸⁸

In the promptbooks, Meyerhold noted down precise instructions for the action on stage to accompany every line of text. Eisenstein, who had worked as a military engineer and set designer for the Communist agitprop theater, was first introduced to biomechanics as a course participant and then as Meyerhold's assistant.³⁸⁹ In 1923 he went on to stage Alexander

387 See Sacha Gervasi: *Hitchcock*, DVD, Frankfurt a.M.: Twentieth Century Fox 2013 [2012].

388 On this paragraph, see Alma Law and Mel Gordon: *Meyerhold, Eisenstein and Biomechanics. Actor Training in Revolutionary Russia*, Jefferson/London: McFarland 1996, pp. 13–73.

389 See Law and Gordon: *Meyerhold, Eisenstein and Biomechanics*, pp. 74–80.

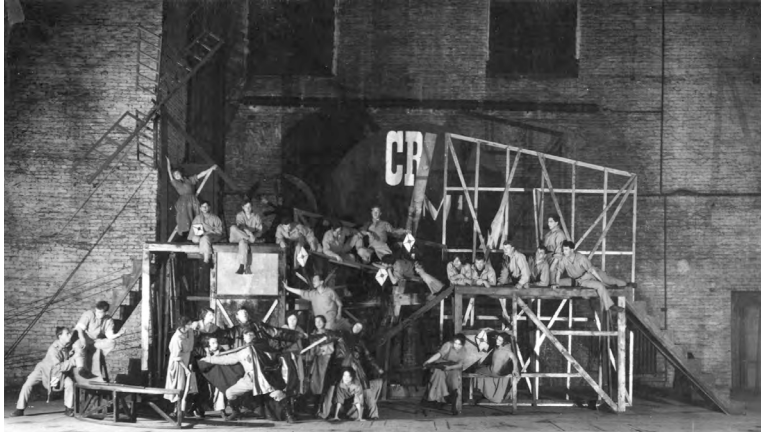

Fig. 91: Photograph of Vsevolod Meyerhold's staging of the play *Le cocu magnifique* by Fernand Crommelynck in Moscow in 1922; the Constructivist set was designed by Lyubov Popova. Source: Russian State Archives of Literature and Art (RGALI, Moscow), fund 1923 inventory 2 folder 2262 p. 4.

Ostrovsky's comedy *Enough Stupidity in Every Wise Man* and called his directorial concept a "montage of attractions":

*An attraction (in our diagnosis of theatre) is any aggressive moment in theatre, i.e. any element of it that subjects the audience to emotional or psychological influence, verified by experience and mathematically calculated to produce specific emotional shocks in the spectator in their proper order within the whole.*³⁹⁰

As a theater engineer, the director mounts attractions in the sense of independent performances, which do not portray a plot realistically but are intended to give the audience an emotional shock and influence them ideologically. Yet while the theater audience can tangibly experience the play, in film, as Eisenstein understood it, psychological associations are provoked and interconnected in the viewers' minds.³⁹¹ Consequently, although the aforementioned shower scene in

390 Sergei Eisenstein: "The Montage of Attractions" [Russian 1923], in: *Selected Works. Vol. 1: Writings, 1922–34*, ed. and trans. Richard Taylor, London: BFI 1988, pp. 33–38, here p. 34.

391 See Sergei Eisenstein: "The Montage of Film Attractions" [Russian 1924], in: *Selected Works. Vol. 1: Writings, 1922–34*, ed. and trans. Richard Taylor, London: BFI 1988, pp. 39–58, here p. 41.

Hitchcock's *Psycho* features close-ups of the murderer's stabbing arm, the victim's writhing body, and the blood flowing down the drain, it does not show the knife puncturing the skin or the blood splattering.³⁹² The actual murder is associated in the viewer's psyche from these sensory impressions.

Eisenstein systematically implemented this "montage of film attractions" in the 1920s, constantly developing and improving his technique. In an article from 1929, he relates the metric montage that sets the audience in motion by making, for example, "the hands and feet quiver" to the intellectual montage where "this quivering, provoked by an intellectual stimulant combined differently, produces an identical reaction in the tissues of the higher nervous system of the thought apparatus."³⁹³ According to Eisenstein's stimulant-reaction-technique, using a montage of visual objects, whether they be human actors or not, the director could affect the audience as a physical "material" and "plough its psyche."³⁹⁴ In the eyes of Walter Benjamin, this "shock effect of film" was consistent with everyday life in the modern metropolises of the twentieth century and "seeks to induce heightened attention."³⁹⁵

Therefore, in contrast to the clumsy editing in the *N.S. Ton-Bild-Bericht Nr. 2*, artistic montage was not intended to achieve its effects via the content shown, but rather affect the viewers' perceptual apparatus directly. With *Battleship Potemkin*, which premiered in Moscow in 1925, Eisenstein appears to have accomplished this perfectly. His contemporaries spoke of this film, dealing with the mutiny on the warship "Potemkin" in the Russian Revolution of 1905, as having both physical and

392 See Alfred Hitchcock: *Psycho*, DVD, Universal City: Universal Studios 1999 [1960].

393 Sergei Eisenstein: "The Fourth Dimension in Cinema" [Russian 1929], in: *Selected Works. Vol. 1: Writings, 1922–34*, ed. and trans. Richard Taylor, London: BFI 1988, pp. 181–194, here p. 193.

394 Eisenstein: "The Montage of Film Attractions," p. 56, and Sergei Eisenstein: "The Problem of the Materialist Approach to Form" [Russian 1925], in: *Selected Works. Vol. 1: Writings, 1922–34*, ed. and trans. Richard Taylor, London: BFI 1988, pp. 59–64, here p. 62.

395 Walter Benjamin: "The Work of Art in the Age of Its Technological Reproducibility," trans. Harry Zohn and Edmund Jephcott [German 1936/39], in: *Selected Writings. Vol. 4: 1938–1940*, ed. Michael W. Jennings, Cambridge: Harvard University Press 2006, pp. 251–283, here p. 267.

Fig. 92, p. 219

psychological impacts. For the censored **German version**, which came to cinemas in spring 1926, the Viennese composer Edmund Meisel devised the score. The management of the film company Prometheus, which produced and distributed the German *Panzerkreuzer Potemkin*, wrote to Eisenstein about the premiere in Berlin, emphasizing Meisel's achievement: "The music was at times so intense that in combination with the pictures on the screen it had such an impact on the viewers that they had to hold onto their seats in excitement."³⁹⁶ Regarding the ideological impact, the Nazi Propaganda Minister Joseph Goebbels highlighted in March 1933 that *Battleship Potemkin* had been "marvelously made. [...] Those who are not steadfast in their worldview might become Bolsheviks as a result of this film."³⁹⁷

The German version of Eisenstein's most famous film was censored again in summer 1926 and then rereleased two years later in a slightly altered form by the Prometheus distribution company. This 1,464-meter-long *Panzerkreuzer Potemkin* from 1928 ultimately served as the basis for a sound version for which not only did Meisel compose new music



Fig. 92: Poster for the German version of Sergei Eisenstein's film *Battleship Potemkin* from 1926. Source: Vienna City Library, P-42361.

396 "Prometheus Filmverleih- und Vertriebs GmbH, Berlin, an Sergej Eisenstein, Moskau, 1. Juni 1926," in: Oksana Bulgakowa (ed.): *Eisenstein und Deutschland. Texte, Dokumente, Briefe*, Berlin: Akademie der Künste 1998, pp. 75–78, here p. 76 [our trans.].

397 Joseph Goebbels: "Rede im Kaiserhof am 28.3.1933," in: Gerd Albrecht (ed.): *Der Film im Dritten Reich. Eine Dokumentation*, Karlsruhe: Doku Verlag 1979, pp. 26–31, here p. 27 [our trans.].

Fig. 82, p. 202

and sound effects, but dialogues and chants were also post-dubbed.³⁹⁸ Whether the screening in Vienna on the night of May 13, 1933, was of a silent version with a musical accompaniment or the sound version of 1930, which had been made using the sound-on-disc technique, is not possible to establish for certain. According to archival documents, combined optical sound and sound-on-disc equipment was installed at the Friedensbrücken Kino in 1931, which was replaced that same year with a model by the German Klangfilm GmbH.³⁹⁹ Although Klangfilm used the **optical sound technique**, it also offered additional equipment that made it possible to screen synchronous sound-on-disc films, i.e., with phonographs.⁴⁰⁰ However, the official certificate of the Friedensbrücken Kino from 1933 only refers to an optical sound machine.⁴⁰¹

The second work to be screened by the Association of Friends of the Soviet Union (*Bund der Freunde der Sowjetunion*) on this communist movie night was only ever available in a silent version. In 1929, when *Turksib* was released, sound film was already starting to prevail in the USA and increasingly in Europe. However, in the Soviet Union work was underway on several sound film systems in order to avoid being dependent on the Western patents.⁴⁰² The Russian director Viktor Turin had studied at the Massachusetts Institute of Technology (MIT) and worked as a screenwriter in Hollywood before returning to the Soviet Union and shooting *Turksib* for the film company Vostok Kino: the film was a documentary about the

398 Both the German premiere version from 1926 and the German sound version from 1930 are contained in the DVD *Panzerkreuzer Potemkin & Oktjabr'*, Munich: Edition Filmmuseum 2014.

399 See Municipal and Provincial Archives of Vienna (WStLA, M.Ab. 471, A3/1, Friedensbrücken-Kino, official letters from December 11, 1930, and September 8, 1931).

400 See Emil Mechau: "Der Wiedergabeprojektor" and "Das Universal-Tonzusatzgerät," in: Fritz Fischer and Hugo Lichte (eds.): *Tonfilm. Aufnahme und Wiedergabe nach dem Klangfilm-Verfahren (System Klangfilm-Tobis)*, Leipzig: Hirzel 1931, pp. 271–283.

401 See Municipal and Provincial Archives of Vienna (WStLA, M.Ab. 471, A3/1, Friedensbrücken-Kino, certificate no. 4694 from October 14, 1933).

402 See Harald Jossé: *Die Entstehung des Tonfilms. Beitrag zu einer faktenorientierten Mediengeschichtsschreibung*, Freiburg/Munich: Karl Alber 1984, pp. 281–282.

898-mile-long railroad line from Turkestan to Siberia, which was constructed from late 1926 to early 1931.⁴⁰³ “In several respects, ‘Turksib’ is characteristic of the new direction of Russian film art,” wrote the film critic Fritz Rosenfeld on the day of the **Viennese premiere**, April 4, 1930, in the Social Democratic *Arbeiter-Zeitung*, “it is no longer a feature film; it dispenses with the studio and the actors and nevertheless it is not a documentary film [*Kulturfilm*] in the usual sense, but rather a dramatically modeled filmic document [...]”⁴⁰⁴

Fig. 93, p. 221



Fig. 93: Poster for the Viennese premiere of Viktor Turin’s film *Turksib* on April 4, 1930. Source: Vienna City Library, P-42133.

Turin had presented excerpts from the film in Vienna two months previously at the Society of Engineers and Architects (*Ingenieur- und Architektenverein*) and emphasized in his introduction that the Soviet directors depicted social conflicts rather than individual heroes. In the case of *Turksib*, however, the film was not about a communist class war, but the “development of our country from complete technological backwardness and barbarism to colossal progress,” as Turin explained in his lecture in Vienna.⁴⁰⁵ This modernization process is embodied by two opposing collectives in the film: while the Russian engineers

403 See Ingrid Kleespies: “Riding the Soviet Iron Horse. A Reading of Viktor Turin’s *Turksib* through the Lens of John Ford,” in: *Slavic Review*, 77/2 (2018), pp. 358–389, here pp. 359 and 366–367. The English version of Viktor Turin’s *Turksib*, released by John Grierson in 1930, is contained in the DVD *The Soviet Influence. From Turksib to Night Mail*, London: BFI 2011.

404 Fritz Rosenfeld: “Die Front des Friedens,” in: *Arbeiter-Zeitung* (Vienna), April 4, 1930, p. 8 [our trans.].

405 Cit. after “Wesen und Arbeitsmethoden des Sowjetfilms,” in: *Die Rote Fahne* (Vienna), February 9, 1930, p. 7 [our trans.].

together with air hammers and mechanical diggers represent the “colossal progress,” the “backwardness and barbarism” appear in the form of the Kazakh nomads with their donkeys and camels. Yet in *Turksib* the railroad is not shown as a synthesis of modern and natural life. Instead, the “steel path,” the original title of the film, was intended to liberate the rural territories from the forces of nature. In truth, during the Soviet collectivization of 1931 to 1933, the Kazakhs lost not only their nomadism, but some 1.75 million of them also their lives.⁴⁰⁶

406 See Matthew J. Payne: “Viktor Turin’s ‘Turksib’ (1929) and Soviet Orientalism,” in: *Historical Journal of Film, Radio and Television*, 21/1 (2001), pp. 37–62, here p. 55.

2.4 Cinema: Mabuse's Control Center



place	UFA Ton Kino
moment	Screening of <i>The Testament of Dr. Mabuse</i>
space	8 km 112 m from the start
time	20 h 15 min before the end

Fig. 23, p. 63

II.10

After the Austrian premiere had taken place on Friday, May 12, 1933, Fritz Lang's *Das Testament des Dr. Mabuse* (*The Testament of Dr. Mabuse*) was screened in **eight movie theaters** in Vienna on the weekend of the “**Turks Deliverance Celebration**” (*Türkenbefreiungsfeier*). The film aroused considerable public interest because the director was a Vienna-born celebrity and his latest work was banned in Germany.⁴⁰⁷ It was Lang's second sound feature after *M* (1931) and was again produced by the Berlin Nero Film AG. The screenplay was written by his wife Thea von Harbou, based on a then still unpublished novel by Norbert Jacques, who had already provided the literary source for Lang's silent film *Dr. Mabuse, der Spieler* (*Dr. Mabuse the Gambler*, 1922).⁴⁰⁸ However, even in the sequel the insane Mabuse, played by Rudolf Klein-Rogge, does not speak but merely writes instructions for crimes in his cell, which are then carried out by a criminal organization. The go-between is Mabuse's doctor, Professor Baum (Oscar Beregi), who communicates with the criminal network via telegram and telephone and gives the most important instructions in a kind of control center.⁴⁰⁹

407 See Rolf Aurich, Wolfgang Jacobson, Cornelius Schnauber (eds.): *Fritz Lang. Leben und Werk. Bilder und Dokumente*, Berlin: jovis 2001, pp. 194–201.

408 Jacques's novel on which the film *Das Testament des Dr. Mabuse* was based was only published in 1950 under the title *Dr. Mabuses letztes Spiel* by Hoffmann & Campe in Hamburg. On the genesis of the movie and the book, see the appendix in Norbert Jacques: *Das Testament des Dr. Mabuse*, ed. Michael Farin and Günter Scholdt, Hamburg: Rogner & Bernhard 1994, pp. 217–274.

409 See Fritz Lang: *Das Testament des Dr. Mabuse*, 35 mm film, Berlin: Nero Film AG 1933, source: Film Archive of the Federal Archives (Berlin), BSP 26989-12.



Fig. 94: Still from Fritz Lang's film *The Testament of Dr. Mabuse* (1933): the mysterious man behind the curtain instructs his subordinates in the control center. Source: Film Archive of the Federal Archives (Berlin), BSP 26989-12.



Fig. 95: Still from Fritz Lang's film *The Testament of Dr. Mabuse* (1933): Kent (Gustav Diessl) and Lilli (Wera Liessem) gaze behind the curtain in the control center. Source: Film Archive of the Federal Archives (Berlin), BSP 26989-12.



Fig. 96: Still from Fritz Lang's film *The Testament of Dr. Mabuse* (1933): the man behind the curtain in the control center turns out to be a dummy with microphone and loudspeaker. Source: Film Archive of the Federal Archives (Berlin), BSP 26989-12.

Fig. 94, p. 224

When the associates are summoned to this “room with the curtain,” they first have to open two doors with safety locks. Upon entering, the **silhouette of a seated man** appears behind a curtain, which divides the room. The wallpaper is peeling off the walls; the outline of a urinal can be made out next to the door; a window is bricked up. A male voice not only tells those present what they must do but also reacts to their behavior. Those who move are called to order. No one knows what the “boss” looks like, and no one would dare to peer behind the curtain since a colleague was killed for doing just that. The

Fig. 96, p. 224

secret is only aired when a rogue associate, Kent (Gustav Diessl), is locked in the room with his lover, Lilli (Wera Liessem). He shoots at the curtain, rips it aside, and discovers a **table with a microphone and loudspeaker** behind which a dummy is affixed. The couple escape a ticking time bomb thanks to Kent piercing the pipe that leads to the removed urinal with a knife and a revolver and filling the room with water until the pressure breaks a hole in the wooden floor.

Fig. 95, p. 224

In the specialist literature, readers' attention is often drawn to the similarities between Mabuse's control center and the movie theater.⁴¹⁰ What Kent and Lilli discover is in principle the equipment for screening sound films. However, Lang appears to be intentionally trying to disorient the audience in this sequence, because the angle of the shots alternates axially between the curtain and the door, or, to continue the analogy, between the screen and the seats. The dummy's shadow is cast onto the curtain like the film's images onto a screen. But at the point of the reveal, it seems as though Kent and Lilli were breaking the fourth wall and **looking straight at the audience**. Furthermore, not only is there a loudspeaker on the table, but also a microphone to transmit or record sounds. It is certainly striking that the sound film *The Testament of Dr. Mabuse* reflects its use of audiovisual technology.⁴¹¹ Hence, the fictional control center alludes to the type of cinema that was becoming established internationally around 1930.

II.5 &
Fig. 101, p. 234

The development from theater to cinema can be demonstrated by the **UFA Ton Kino** at Taborstrasse 8, for example, which was one of the locations for the Vienna premiere of *The Testament of Dr. Mabuse* and screened the film at 4:45, 7:00,

410 See, for example, Michel Chion: *La voix au cinéma*, Paris: Editions de l'Etoile 1993 [1982], pp. 45–46; Tom Gunning: *The Films of Fritz Lang. Allegories of Vision and Modernity*, London: BFI 2000, pp. 151–153; Brigitte Peucker: "Fritz Lang. Object and Thing in the German Films," in: Joe McElhaney (ed.): *A Companion to Fritz Lang*, Chichester: Wiley & Sons 2015, pp. 279–299, here p. 290.

411 See Lucy Fisher: "Dr. Mabuse and Mr. Lang," in: *Wide Angle*, 3/3 (1979), pp. 18–26, and Jonathan Crary: "Dr. Mabuse and Mr. Edison," in: Russell Ferguson (ed.): *Art and Film Since 1945. Hall of Mirrors*, New York: Monacelli 1996, pp. 262–279.



Fig. 97: The auditorium on the ground floor of Hotel Central at Taborstrasse 8 in Vienna, where the Budapest Orpheum Society performed from 1903 to 1913. Source: Schick Hotels Betriebs GmbH (Vienna).

and 9:10 p.m. that weekend, May 13 and 14, 1933.⁴¹² The cinema had opened as the Central Kino on the ground floor of Hotel Central in 1916, where a theater had been installed around 1900, which was also available to rent for events by associations and individuals. A theatrical ensemble founded in 1889 that had previously performed in the building opposite, the Hotel Zum Schwarzen Adler at Taborstrasse 11, the Budapest Orpheum Society (*Budapester Orpheum Gesellschaft*) played the “musical comedy hall” at the Central from summer 1903. “In front of what was mostly a full house, a four-hour program was offered every day until the outbreak of war in 1914,” writes Georg Wacks of the Budapest Orpheum: “The program comprised solo cabaret recitals, performances by various comedians, musical interludes by Viennese folk and operetta singers, dance performances, and guest appearances by nonresident artists.”⁴¹³ Loved for its Jargon theater, the ensemble combined Viennese and Jewish dialects into the

412 See “Kino-Programme,” in: *Die Stunde* (Vienna), May 13 and 14, 1933, p. 4.

413 Georg Wacks: “Der schöne Moritz von der Klabriaspattie. Die Budapest Orpheum Gesellschaft. Eine Ausnahmeerscheinung der Wiener Unterhaltungskultur,” in: Marie-Theres Arnbom and Georg Wacks (eds.): *Jüdisches Kabarett in Wien. 1889–2009*, Vienna: Armin Berg 2009, pp. 53–62, here p. 54 [our trans.].

“Jiddeln” that was an everyday language in the Leopoldstadt, Vienna’s second district through which the Taborstrasse runs.⁴¹⁴

Fig. 97, p. 226

The **auditorium** at Hotel Central was licensed for 540 people. In front of the stage was the orchestra, followed first by reserved and then free seats. The audience sat at tables, each with five chairs, and generally ate and drank during the performances. In the loges there were also curtains to allow their occupants to withdraw into a *chambre séparée*. In the summer the Budapester Orpheum mostly performed in the amusement park in Vienna’s Prater, and every fall the ensemble had to leave the Central for ten days because the hotel’s auditorium was repurposed as a temple on the Jewish Days of Repentance from Rosh Hashana to Yom Kippur. After Carl Lechner, the director of the society, had received police authorization to screen stereoscopic, i.e., apparently three-dimensional, images in public in 1904, the Budapester Orpheum also included the cinematograph in its program over the next two years.⁴¹⁵

“Life is captured everywhere where the lens was pointed and everything that happened faithfully reappears,” according to a flyer circulated when the Cinématographe of Auguste and Louis Lumière from Lyon was presented in Vienna.⁴¹⁶ Several roughly one-minute 35 mm films were screened daily from 10 a.m. to 8 p.m. from March 26, 1896, at Kärntner Strasse 45. The apparatus could photograph and project sixteen frames per second, which the human eye only just recognizes as flowing movement. In the years that followed, cinematography became a permanent attraction in Vienna’s Prater and in variety shows. Around the time when cinematographic

- 414 Vienna’s Leopoldstadt is named after Emperor Leopold I, who had the Jewish population banished from this part of the city between the Danube Canal and the Danube River in 1670, where there had been a ghetto since 1624. Despite their temporary forced displacement, the Leopoldstadt remained a district with many Jewish inhabitants until World War II. See Ruth Beckermann (ed.): *Die Mazzesinsel. Juden in der Wiener Leopoldstadt 1918–1938*, Vienna: Löcker 1984.
- 415 See Georg Wacks: *Die Budapester Orpheumgesellschaft. Ein Varieté in Wien 1889–1919*, Vienna: Holzhausen 2002, pp. 148–187.
- 416 Flyer “Die lebende Photographie,” Vienna: Philipp & Kramer 1896, source: Vienna City Library, Printed Works Collection, E-109891.

recordings were also being shown at Hotel Central, the first permanent movie theaters became established in the city: by 1906 there were already seventeen cinemas in Vienna.⁴¹⁷ That might have been one reason why the Budapest Orpheum only screened films for one year before returning to concentrate on its core business, Jewish cabaret shows. Finally, in 1913 the ensemble moved to its own theater built a five-minute walk away at Praterstrasse 25.⁴¹⁸

During World War I, the Committee of Daycare Centers for War Orphans and Needy Children of Enlisted

Persons (*Komitee der Tagesheimstätten für Krieger-Waisen und bedürftige Kinder von Eingerückten*) made an application to the police headquarters in Vienna for permission to open a movie theater in the auditorium of Hotel Central.⁴¹⁹ For this purpose, the stage had to be bricked up and a waiting room for the audience as well as a projection room for the film projector had to be built. While the loges could remain unchanged, the tables were removed from the parterre and replaced with 614 folding chairs in twenty-four rows parallel to the screen. With the additional loges and seats on the balcony, there were a total of 1,008 seats available for the audience. The **Central Kino** was awarded a “cinematograph license” for this capacity

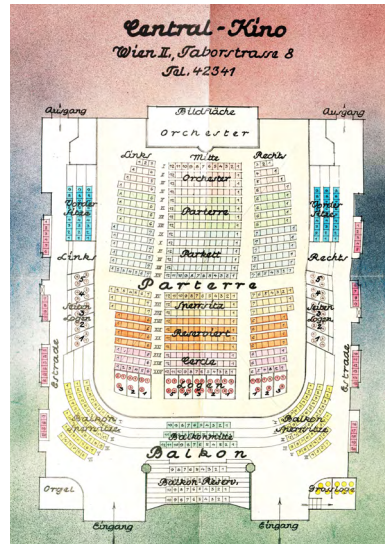

Fig. 98: The auditorium of the Central Kino at Taborstrasse 8 in Vienna in 1925. Source: Municipal and Provincial Archives of Vienna, 1.3.2.104.A11.2.Zentralkino.

Fig. 98, p. 228

417 This number is derived from the documentation in Werner Michael Schwarz: *Kino und Kinos in Wien. Eine Entwicklungsgeschichte bis 1934*, Vienna: Turia + Kant 1992, pp. 179–296.

418 See Wacks: “Der schöne Moritz von der Klabriaspattie,” p. 61.

419 The application from 1916 is documented in the Municipal and Provincial Archives of Vienna (WStLA, M.Ab. 104, A11, Zentralkino).

on October 4, 1916.⁴²⁰ Its first manager was the journalist, screenwriter, and later film director Alfred Deutsch-German. The orchestra remained immediately in front of the stage, which now housed the screen, and in 1925 a theater organ was added on the occasion of the premiere of the film *The Ten Commandments*.⁴²¹

In 1930 the management sold the organ to the Sievering parish in Vienna's nineteenth district.⁴²² The year before, the Central Kino had been fitted with sound film equipment and renamed the "UFA-Ton-Kino." The Central Association for Feeding the People (*Zentralverein für Volksernährung*), which had taken over the permit for its operation in 1926, justified the name change to the responsible municipal authority with the introduction of sound film and the fact that it was a premiere cinema for the German Universum Film AG (UFA), which had long been involved in the Central Kino.⁴²³ In April 1929 the influential German film company concluded a cooperation agreement with Klangfilm GmbH, which had been founded by the electrical corporations Siemens & Halske and AEG.⁴²⁴ Consequently, in the summer of 1929 sound film equipment by the Klangfilm brand was installed at Vienna's UFA Ton Kino. However, it was not a mere optical sound system after the Klangfilm method, but rather the "Uniton" model, which was attached to the existing projectors and could be supplemented with a phonograph.⁴²⁵

420 See Municipal and Provincial Archives of Vienna (WStLA, M.Abt. 104, A11, Zentralkino, cinematograph license from October 4, 1916).

421 See Karl Schütz: *Theater- und Kinoorgeln in Wien*, Vienna: Österreichische Akademie der Wissenschaften 1991, pp. 99–100.

422 See Schütz: *Theater- und Kinoorgeln in Wien*, pp. 101–102.

423 See Municipal and Provincial Archives of Vienna (WStLA, M.Abt. 104, A11, Zentralkino, letter from the Zentralverein für Volksernährung to Vienna's municipal department 52, arrived on August 15, 1929).

424 See Michael Wedel: "Klärungsprozesse. Tobis, Klangfilm und die Tonfilmumstellung 1928–32," in: Jan Distelmeyer (ed.): *Tonfilmfrieden/ Tonfilmkrieg. Die Geschichte der Tobis vom Technik-Syndikat zum Staatskonzern*, Munich: edition text + kritik 2003, pp. 34–43, here p. 35.

425 See Municipal and Provincial Archives of Vienna (WStLA, M.Abt. 104, A11, Zentralkino, inspection of the electrical installation in the UFA Ton Kino on March 23, 1931, "sound film apparatus: 'Klangfilm Uniton,' 2 x 30 watts, optical sound and sound-on-disc" [our trans.]).

Attempts to combine sound and image had existed since the very beginnings of cinematography. In the German-speaking world, the “Biophon” by Oskar Messter was the most famous, which was presented in Berlin in 1903 and connected the film projector with a gramophone.⁴²⁶ However, the early sound-on-disc methods did not catch on because the synchronous recording and playback of films and records was too complicated at that time and the results mostly poor. These technical difficulties could be remedied after World War I when the electronic tube amplifiers first patented by Robert von Lieben (1906) and Lee de Forest (1907) were used.⁴²⁷ Though not uncontested in specialist literature, the breakthrough for sound film is generally considered to be *The Jazz Singer*, which premiered in New York in 1927 and which Warner Brothers had produced using their sound-on-disc technique called Vitaphone.⁴²⁸ What was novel about Alan Crosland’s motion picture about a New York singer and son of a Jewish cantor who rises from the ghetto on the Lower East Side to become a musical star on Broadway was not only the musical interludes integrated in the plot, but above all a short monologue by the leading actor Al Jolson and a dialogue between him and his on-screen mother.⁴²⁹

The Jazz Singer premiered in Austria on January 21, 1929, namely at the Central Kino at Taborstrasse 8 in Vienna. However, what was shown was neither the American original nor a post-dubbed German version, but rather a silent version with intertitles, which was accompanied by music from the

- 426 See Wolfgang Mühl-Benninghaus: “Vom Stummfilm zum Tonfilm,” in: Joachim-Felix Leonhard et al. (eds.): *Medienwissenschaft. Ein Handbuch zur Entwicklung der Medien und Kommunikationsformen*, vol. 2, Berlin/New York: Walter de Gruyter 2001, pp. 1027–1032, here p. 1027.
- 427 See Olaf Schumacher and Hans Jürgen Wulff: “Warner, Fox, Tobis-Klangfilm und die Anfänge des Tonfilms,” in: Joachim-Felix Leonhard et al. (eds.): *Medienwissenschaft. Ein Handbuch zur Entwicklung der Medien und Kommunikationsformen*, vol. 2, Berlin/New York: Walter de Gruyter 2001, pp. 1198–1207, here pp. 1198–1200.
- 428 See Donald Crafton: *The Talkies. American Cinema’s Transition to Sound, 1926–1931*, New York: Charles Scribner’s Sons 1997, pp. 516–531.
- 429 See Alan Crosland: *The Jazz Singer*, DVD, Hamburg: Warner Home Video 2007 [1927].

cinema orchestra, as well as singers and records.⁴³⁰ “A swindle,” declared *Das Kleine Blatt*:

*Instead of the greatly hyped sound feature, one is shown mouths opened in silence followed by overabundant inserted text. Now and then use is made of a phonograph, and singers hidden in the gallery attempt in vain to keep in time with the comical movements of the mouths of the film’s characters.*⁴³¹

Fritz Rosenfeld, the film critic at the *Arbeiter-Zeitung*, also trashed the Viennese premiere but found it striking that *The Jazz Singer* was playing “in the movie theater of the German National Ufa” whose lobby had been fitted out as a Jewish “temple” for the event.⁴³² Heinrich Lipsker, the then manager, did indeed set up some vitrines and candelabras from the Jewish Museum, which was located nearby at Malzgasse 16, in the waiting room of the Central Kino in mid-January 1929.⁴³³ Presumably, these loans were intended to establish a connection between the film’s plot about the cantor’s son from the New York ghetto and Jewish life in Vienna’s Leopoldstadt district.

Published in January 1929, the article in the *Arbeiter-Zeitung* also makes it clear that even before the Central Kino was renamed the following August, the involvement of Universum Film AG was common knowledge. Both artistically and commercially successful in the 1920s, the film company had been considered to be “German National” since its founding in 1917, and this perception was only reinforced once it belonged to Alfred Hugenberg’s media group. The cofounder and future president of the German National People’s Party had taken over UFA in 1927, which was in dire financial straits, partly

- 430 The often-cited statement in the Austrian film history by Walter Fritz that *The Jazz Singer* was screened as a sound feature in the Central Kino on January 21, 1929, is wrong. See Walter Fritz: *Kino in Österreich. 1929–1945*, Vienna: ÖBV 1991, p. 15.
- 431 Johann Hirsch: “Der Jazzsänger,” in: *Das Kleine Blatt* (Vienna), January 25, 1929, p. 8 [our trans.].
- 432 Fritz Rosenfeld: “Der Jazzsänger,” in: *Arbeiter-Zeitung* (Vienna), January 23, 1929, p. 6 [our trans.].
- 433 See Municipal and Provincial Archives of Vienna (WStLA, M.Ab. 104, A11, Zentralkino, letter incl. sketch from the Central Kino GmbH to Vienna’s municipal department 58, dated January 18, 1929).

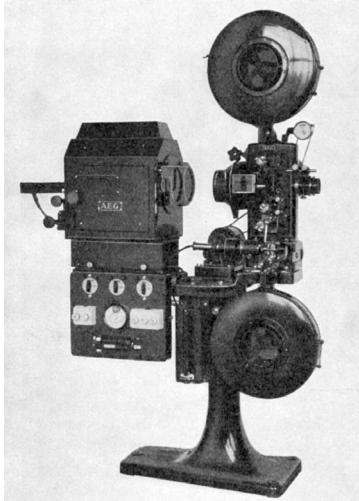

Fig. 99: An AEG projector for 35 mm film with an optical sound projector by Klangfilm GmbH, printed in Fritz Fischer and Hugo Lichte (eds.): *Tonfilm. Aufnahme und Wiedergabe nach dem Klangfilm-Verfahren (System Klangfilm-Tobis)*, Leipzig: Hirzel 1931, fig. 242. Source: Austrian Central Library for Physics (Vienna), 1755.

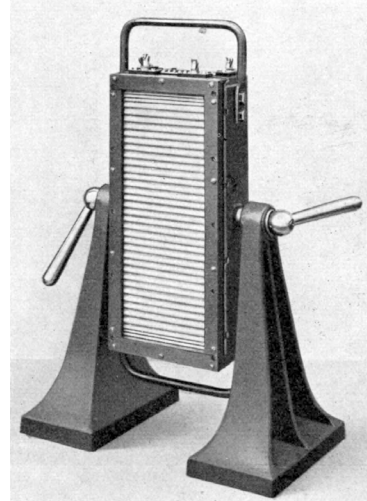

Fig. 100: The so-called "Blatt-haller," an electrodynamic loudspeaker by Siemens & Halske, printed in Fritz Fischer and Hugo Lichte (eds.): *Tonfilm. Aufnahme und Wiedergabe nach dem Klangfilm-Verfahren (System Klangfilm-Tobis)*, Leipzig: Hirzel 1931, fig. 155. Source: Austrian Central Library for Physics (Vienna), 1755.

because of Fritz Lang's film *Metropolis* whose production had cost over five million reichsmarks.⁴³⁴ In the course of its financial recovery, the experiments with optical sound were abandoned, which had been conducted by the company in collaboration with the Tri-Ergon group of inventors since the mid-1920s.⁴³⁵ After the founding of the German Tonbild Syndikat AG, known as Tobis for short, and Klangfilm GmbH, which signed a cooperation agreement in March 1929, UFA concluded the aforementioned contract with Klangfilm, which

434 See Klaus Kreimeier: *Die Ufa-Story. Geschichte eines Filmkonzerns*, Munich/Vienna: Hanser 1992, pp. 176–205.

435 See Harald Jossé: *Die Entstehung des Tonfilms. Beitrag zu einer faktenorientierten Mediengeschichtsschreibung*, Freiburg/Munich: Karl Alber 1984, p. 236.

is probably what led to the sound film equipment being fitted in Vienna's Central Kino.⁴³⁶

Fig. 99, p. 232

The schematic of the Klangfilm equipment at the Central Kino has been preserved in the Municipal and Provincial Archives of Vienna.⁴³⁷ The two apparatuses it shows each comprise a **motion-picture and a sound projector**, as well as a phonograph, which were powered by an electric motor, meaning that 35 mm films could be screened silently, with optical sound, or with records being played synchronously at a constant speed of twenty-four frames per second. For the sound reinforcement system in the auditorium, which was now licensed to hold 1,048 people, two "Blatthaller" were deployed, presumably positioned to the left and right of the screen. The Blatthaller was an electrodynamic loudspeaker by Siemens & Halske, which was available in a range of versions around 1930.⁴³⁸ According to the AEG schematic from 1929, the 20 cm wide and 54 cm tall, that is, the **smaller model** of the loudspeaker was used in the Central Kino, which allowed the sound direction to be steered more easily than the bigger "Riesenblatthaller." Nevertheless, the acoustics still appear to have caused problems, because the following year the interior of the UFA Ton Kino was clad in fabric to improve the sound quality.⁴³⁹

Fig. 100, p. 232

Fig. 82, p. 202

At first, most sound features were released in both an optical sound and a sound-on-disc version.⁴⁴⁰ However, it did not take long for the **optical sound method** to become prevalent, the product of which, a soundtrack recorded on film, was easier to **cut and combine with the images** than the records. As such, Fritz Lang's *The Testament of Dr. Mabuse* was also filmed using the Tobis-Klangfilm system in 1932 before being distributed in early 1933 as an optical sound film in

III.2.3 &
Fig. 90, p. 214

436 See Wedel: "Klärungsprozesse," p. 35.

437 See WStLA, M.Abt. 104, A11, Zentralkino.

438 See Ferdinand Trendelenburg: "Der Blatthaller," in: Fritz Fischer and Hugo Lichte (eds.): *Tonfilm. Aufnahme und Wiedergabe nach dem Klangfilm-Verfahren (System Klangfilm-Tobis)*, Leipzig: Hirzel 1931, pp. 171–174.

439 See Municipal and Provincial Archives of Vienna (WStLA, M.Abt. 104, A11, Zentralkino, letter from the UFA Ton Kino to Vienna's municipal department 52, dated June 10, 1930).

440 See Wedel: "Klärungsprozesse," p. 40.



Fig. 101: The UFA Ton Kino, located on the ground floor of Hotel Central at Taborstrasse 8 in Vienna, photographed on April 13, 1944. Source: Austrian National Library, 162.307A(B).

35 mm format.⁴⁴¹ On the same day that the feature film was banned in Germany, March 29, 1933, the board of UFA decided to terminate all employment contracts with Jewish employees.⁴⁴² A government under the leadership of Adolf Hitler had been in office in the German Reich for just two months; not only was Alfred Hugenberg part of this administration as its economy minister, but now also Propaganda Minister Joseph Goebbels, who had personally demanded that *The Testament of Dr. Mabuse* be banned.⁴⁴³

Shortly before the film's premiere at the **UFA Ton Kino** in Vienna, there was a change of management. On May 9, 1933, the Central Association for Feeding the People as the licensee reported to the municipal authorities that Heinrich Lipsker had "left our services" and Hermann Stritzko had taken his

Fig. 101, p. 234

- 441 On the format of the original version, see the full credits of the movie *Das Testament des Dr. Mabuse* (1933) at filmportal.de, URL: www.filmportal.de/film/das-testament-des-dr-mabuse_2ab1c65e6aed44dfac401ad99147182d.
- 442 See Kreimeier: *Die Ufa-Story*, p. 248.
- 443 See Aurich et al. (eds.): *Fritz Lang*, p. 194.

place.⁴⁴⁴ The new manager was evidently a member of the NSDAP, which was banned in Austria in June 1933: in May 1939, at which point the country had been part of the German Reich for over a year, a report from the Viennese branch of the Reich Chamber of Film (*Reichsfilmkammer*) stated that party comrade Stritzko had conducted himself “as an upstanding and respectable National Socialist throughout all the years of the prohibition.”⁴⁴⁵ Heinrich Moses Lipsker, in contrast, was deported from Vienna to Kaunas by train on November 23, 1941, together with 997 other Jews, where he was shot six days later by Lithuanian auxiliaries of a National Socialist task force.⁴⁴⁶

- 444 See Municipal and Provincial Archives of Vienna (WStLA, M.Abt. 104, A11, Zentralkino, written request from May 9, 1933, approved on June 2, 1933 [our trans.]).
- 445 See Municipal and Provincial Archives of Vienna (WStLA, Reichsfilmkammer, Aussenstelle Wien, A1 – Kinoakten: 135 – UFA-Theater, letter from the Reichsfilmkammer Aussenstelle Wien to the Vienna gau administration (*Gauleitung*) of the NSDAP, dated May 3, 1939 [our trans.]).
- 446 See Wolfgang Scheffler: “Massenmord in Kowno,” in: Wolfgang Scheffler and Diana Schulle (eds.): *Buch der Erinnerung. Die ins Baltikum deportierten deutschen, österreichischen und tschechoslowakischen Juden*, vol. 1, Munich: Saur 2003, pp. 83–188, here pp. 83–87 and 162. That the Heinrich Moses Lipsker who was born in Vienna on July 23, 1879, and murdered in Kaunas on November 29, 1941, was the former manager of the UFA Ton Kino is proven by the historical registration records preserved in the Municipal and Provincial Archives of Vienna.

2.5 Exposure: “Lick Me in the Ass!”



place	Lassalle Hof
moment	Exposure of buttocks
space	10 km 57 m from the start
time	21 h 30 min before the end

- II.1 On Saturday, May 13, 1933, some Nazi politicians from Germany landed on **Aspern airfield** in Vienna shortly after 2 p.m., led by Bavarian Minister of Justice Hans Frank and his Prussian counterpart Hanns Kerrl. The official reason for their journey was to participate in a lawyers' conference; in fact, however, a National Socialist counter-event to the “Turks Deliverance Celebration” (*Türkenbefreiungsfeier*) by the Austrian Homeland Protection (*Heimatschutz*) was being held.
- II.7 place on the Saturday evening at the **Engelmann Arena**, the latter on the Sunday morning in the **gardens of Schönbrunn Palace**. The visitors were welcomed by hundreds of National Socialists at the airfield before driving into the inner city to the **Adolf Hitler House**, the Vienna headquarters of the NSDAP.
- II.10 & III.1.3 II.4 On the sides of the roads, their supporters cheered and their opponents whistled.⁴⁴⁷ The protest was loudest in the Leopoldstadt, Vienna's second district. After the convoy had crossed the Danube River via the Reichsbrücke bridge, the following scene occurred on the left-hand side (in the direction of travel) of Lassallestrasse as stated by *Die Rote Fahne*:

*From the Lassalle Hof, which had been cordoned off by the police, the workers looked down from their windows, but from the back. Body parts were visible that the Nazi ministers were supposed to understand as a call to make the Götz quote a reality.*⁴⁴⁸

447 See “Lärmender Empfang der nationalsozialistischen Minister,” in: *Neue Freie Presse* (Vienna), May 14, 1933 (morning edition), p. 7.

448 “Pfui-Rufe, rote Fahnen und Pfeifkonzert,” in: *Die Rote Fahne* (Vienna), May 14, 1933, p. 2 [our trans.].

Fig. 21, p. 60

According to this report in the Communist party newspaper, the municipal public housing (*Gemeindebau*) at Lassallestrasse 40–44 in Vienna, the Lassalle Hof, was not only decorated with red flags, but some inhabitants showed their buttocks from their windows **as the Nazi politicians from Germany were driving past**. Instead of cheering the visitors like princes as they entered the city or saluting the convoy like a motorized parade, these demonstrators turned their backs and exposed a part of the body that usually remains concealed in the public space. It is worth following the trail laid by the *Rote Fahne*, because in this case the expression “Götz quote” is not just a euphemism, a polite term, but helps us understand this specific gesture of protest.

The Götz quote comes from the play *Götz von Berlichingen mit der eisernen Hand*, which Johann Wolfgang Goethe wrote in 1771 and had published anonymously two years later.⁴⁴⁹ Only these earliest versions, the original and the first printing, contain the expression in full that is also known as the Swabian greeting. Goethe, who was only in his early twenties at the time and had just started working as a lawyer in Frankfurt am Main, based his literary portrayal on the *Lebens-Beschreibung Herrn Gözens von Berlichingen*, the autobiography published in 1731 by a Franconian imperial knight of the Holy Roman Empire who lived at the end of the late Middle Ages and the beginning of the early modern period.⁴⁵⁰ Despite having lost his right hand as a young man and needing to wear a prosthesis, this Gottfried von Berlichingen grew into a notorious mercenary who earned his money primarily with chivalric feuds. In other words, he was paid by private citizens or families to wage war against their enemies. However, Goethe portrayed the historical military entrepreneur as a German freedom fighter, “whom the princes hate, and to whom the oppressed turn.”⁴⁵¹

449 Both versions are printed in Johann Wolfgang Goethe: *Geschichte Gottfriedens von Berlichingen mit der eisernen Hand dramatisiert. Götz von Berlichingen mit der eisernen Hand. Studienausgabe*, ed. Bodo Plachta, Stuttgart: Hiersemann 2017.

450 On the historical Götz von Berlichingen, see Helgard Ulmschneider: *Götz von Berlichingen. Ein adeliges Leben der deutschen Renaissance*, Sigmaringen: Thorbecke 1974.

451 [Johann Wolfgang Goethe:] *Götz von Berlichingen mit der eisernen Hand. Ein Schauspiel*, [without place and publisher] 1773, p. 17 [our trans.].

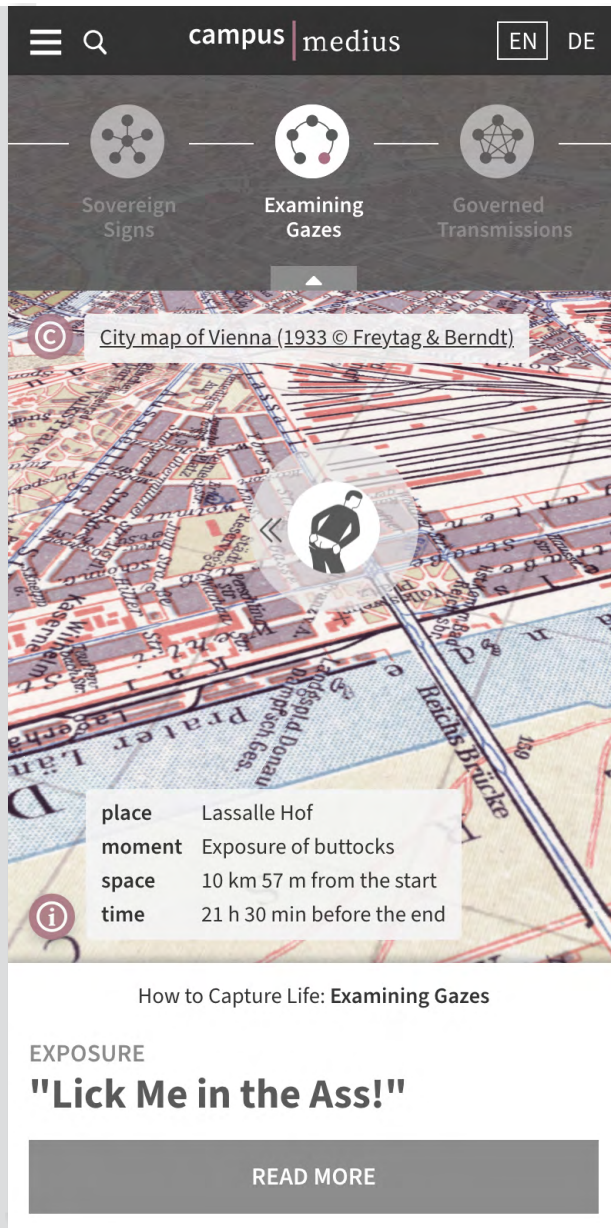

Fig. 102: Screenshot of the Topology module of the website campusmedius.net (mobile version 2.0/2021) showing the mediator “Lick Me in the Ass!” in the mediation “How to Capture Life: Examining Gazes” (text: Simon Ganahl, code: Andreas Krimbacher, design: Susanne Kiesenhofer).

In one of the twenty-one scenes of the third act, Götz entrenches himself with his family in Jagsthausen Castle. As Emperor Maximilian I has imposed the imperial ban (*Reichsacht*) on him, i.e., declared Berlichingen an outlaw for breaching the peace, the imperial army lays siege to his castle. When a messenger calls on him to surrender, Götz shouts out of the window: “Tell your captain: For His Imperial Majesty I have as ever due respect. But he, tell him, he can lick me in the ass.” The scene ends with the stage direction: “(slams the window shut.)”⁴⁵² As an imperial knight of the Holy Roman Empire, Berlichingen is under the direct control of the emperor and, in contrast to his childhood friend and now rival Adelbert von Weislingen, does not serve a territorial prince. He feels personally beholden to Maximilian I but insists on the traditional right of knights to fight feuds. As Götz does not recognize the Roman law according to which the emperor has sentenced him, he considers himself innocent. That means that the Götz quote corresponds in the original text to the meaning of the expression “protection and defiance” (*Schutz und Trutz*), because Berlichingen is not only attempting to protect his territory from invaders, to make his enemy retreat, but also expressing—in a provocative and humiliating way—his defiance, his resistance to authority, through his jeer that his foe should lick him in the ass.

In this passage, Goethe further specified the description in the memoirs of the historical Götz von Berlichingen, who had apparently told a senior civil servant, “he should lick my behind.”⁴⁵³ However, the explicit version in the play is already the verbalization of an action that dates back much further than the Middle Ages. In the mid-nineteenth century, the archaeologist Otto Jahn investigated the superstition that can be found primarily in Greece and Italy since antiquity, according to which envy can have a deleterious effect, which is wielded via the “**evil eye**.”⁴⁵⁴ According to Jahn, the obscene and offensive exposure of the genitalia was one of the ways to hinder or

Fig. 103, p. 240

452 [Goethe:] *Götz von Berlichingen mit der eisernen Hand*, p. 133 [our trans.].

453 *Lebens-Beschreibung Herrn Gözens von Berlichingen*, ed. Franck von Steigerwald, Nuremberg: Adam Jonathan Felssecker 1731, p. 170 [our trans.].

454 See Otto Jahn: “Über den Aberglauben des bösen Blicks bei den Alten,” in: *Berichte über die Verhandlungen der Königlich Sächsischen Gesellschaft der Wissenschaften zu Leipzig. Philologisch-Historische Classe. Siebenter Band*, →



Fig. 103: Stone carving from late antiquity with symbolic representations of means to repel the “evil eye,” among them a man with a Phrygian cap and exposed buttocks (top left), printed in Frederick Thomas Elworthy: *The Evil Eye. An Account of this Ancient & Widespread Superstition*, London: John Murray 1895, fig. 24. Source: Internet Archive.

fend off envious gazes. Showing one’s buttocks as a defensive gesture can also be found in German folk legends, where it is used on the one hand against ghosts or thunderstorms and on the other against besiegers.⁴⁵⁵ In these functions, so-called “mooners” (*Blecker*) also appear on castles, churches, city gates, and patrician houses in wooden or stone form, always facing outward.⁴⁵⁶ While in the profane realm the apotropaic effect of the naked posterior, i.e., its ability to avert evil or bad luck, was at the fore, such grotesque figures inside churches were also depicted as counterpoints to Christian authorities, as representatives of the apostate people of god.⁴⁵⁷

→ Leipzig: Hirzel 1855, pp. 28–110, and more recently John H. Elliott: *Beware the Evil Eye. The Evil Eye in the Bible and the Ancient World. Vol. 2: Greece and Rome*, Cambridge: James Clarke 2016.

455 See Hanns Bächtold-Stäubli: “Hinterer,” in: Eduard Hoffmann-Krayer and Hanns Bächtold-Stäubli (eds.): *Handwörterbuch des deutschen Aberglaubens*, vol. IV, Berlin/Leipzig: Walter de Gruyter 1932, pp. 61–68, here pp. 62–63.

456 The Middle High German verb “blecken” actually means “shine, polish” and was used figuratively to denote “expose.” On the sculpted mooners, see Günter Jerouschek: *“Er aber, sagt ihm, er kann mich im Arsch lecken.” Psychoanalytische Überlegungen zu einer Beschämungsformel und ihrer Geschichte*, Giessen: Psychosozial-Verlag 2005, pp. 21–24.

457 See Katrin Kröll: “Der schalkhaft beredsame Leib als Medium verborgener Wahrheit. Zur Bedeutung von ‘Entblössungsgebärden’ in mittelalterlicher Bildkunst, Literatur und darstellendem Spiel,” in: Katrin Kröll and Hugo Steger (eds.): *Mein ganzer Körper ist Gesicht. Grotteske Darstellungen in der europäischen Kunst und Literatur des Mittelalters*, Freiburg: Rombach 1994, pp. 239–294, here pp. 246 and 271.

Whether the mooners were intended to have more of a protective or lampooning effect is not always clear in every case. The second effect presupposes a hierarchical relationship because an exposed behind is generally aimed at religious or political elders and betters. This kind of insult as a specific act is recorded in Vienna in the late Middle Ages, where according to the chronicler Michael Beheim some Viennese residents showed their naked buttocks to Empress Eleonore and her female entourage in 1462 and shouted to them: “Thou empress and ye virgins! / This mirror ye should merge in!” (“Du kaiserin und ir juncfrawn! / ir solt in dise spiegel schawn!”).⁴⁵⁸ That not only the act but also the linguistic taunt to let someone lick on or in the ass is to be understood as an “expression of defiance” was emphasized by Sigmund Freud in reference to Goethe’s *Götz von Berlichingen*. The founder of psychoanalysis regarded obstinacy—together with orderliness and parsimony—as the result of the sublimation of anal erotism.⁴⁵⁹

Howsoever these psychological connections may develop, it is a fact that the Götz quote expresses in both the gestural and linguistic version a historically established pattern of behavior. Just as Goethe incorporated a figure of speech that was common in southern Germany in his literature, the inhabitants of the Lassalle Hof did not invent the corresponding defiant gesture but simply used it at an appropriate moment. It is remarkable that in both cases the medieval context of the mooners is brought to mind. In the play, the similarity is obvious: the knight Götz von Berlichingen shouts the expletive from a window of his Jagsthausen Castle during its siege. In contrast, at the protest in Vienna on May 13, 1933, this analogy requires further explanation.

The municipality of Vienna invited submissions for the construction of the apartment building named after Ferdinand Lassalle, a pioneer of the German labor movement, in

458 Michael Beheim: *Buch von den Wienern. 1462–1465*, ed. Theodor Georg von Karajan, Vienna: Rohrmann 1843, p. 193 [our trans.].

459 See Sigmund Freud: “Character and Anal Erotism” [German 1908], in: *The Standard Edition of the Complete Psychological Works of Sigmund Freud. Vol. IX: 1906–1908*, ed. and trans. James Strachey, London: Hogarth Press 1959, pp. 167–176, here p. 173.

fall 1923.⁴⁶⁰ As it was in a prominent position in terms of urban planning, the future building should “be particularly exemplary.”⁴⁶¹ What was realized from May 1924, however, was not the winning project by the architect Karl Krist, but the second-place design for a “Lassalle tower” by Hubert Gessner’s office. Like many of the 199 architects who were commissioned with building the 382 municipal public housing projects (*Gemeindebauten*) in Vienna from 1919 to 1934, Gessner had studied under Otto Wagner at the Academy of Fine Arts.⁴⁶² He was supported by Victor Adler, the founder of the Social Democratic Workers’ Party in Austria, and planned among many other buildings the Arbeiterheim Favoriten workers’ house (1902) and the business premises of the party’s Vorwärts publishing house (1910), which also incorporated the editorial department of the Social Democratic *Arbeiter-Zeitung*.

Gessner’s construction style, which became characteristic of public housing in Vienna, was strongly influenced by Wagner’s urban planning, which favored multistory apartment buildings with green courtyards over settlements with row houses.⁴⁶³ Wagner’s students had learned how to deal with large building volumes and insert the new apartment buildings into the former imperial seat in a conservative rather than radical way. Therefore, Viennese public housing not only differs from concepts of the settlement movement (*Siedlerbewegung*), which were advocated by the likes of the architect Adolf Loos, but also from the functional approach of the International Style, which in Germany found expression at the Bauhaus. These differences go beyond the buildings’ external appearance, because to create work for as many people as possible, the communal housing complexes in Vienna were intentionally

460 See Markus Kristan: *Hubert Gessner. Architekt zwischen Kaiserreich und Sozialdemokratie 1871–1943*, ed. Gabriela Gantenbein, Vienna: Passagen 2011, pp. 232–239.

461 “Ein Wettbewerb für Stadtarchitektur,” in: *Arbeiter-Zeitung* (Vienna), October 30, 1923, p. 6 [our trans.].

462 See Hans Hautmann and Rudolf Hautmann: *Die Gemeindebauten des Roten Wien 1919–1934*, Vienna: Schönbrunn-Verlag 1980, pp. 203–206.

463 On this and the following, see Hautmann and Hautmann: *Die Gemeindebauten des Roten Wien 1919–1934*, pp. 205–217.

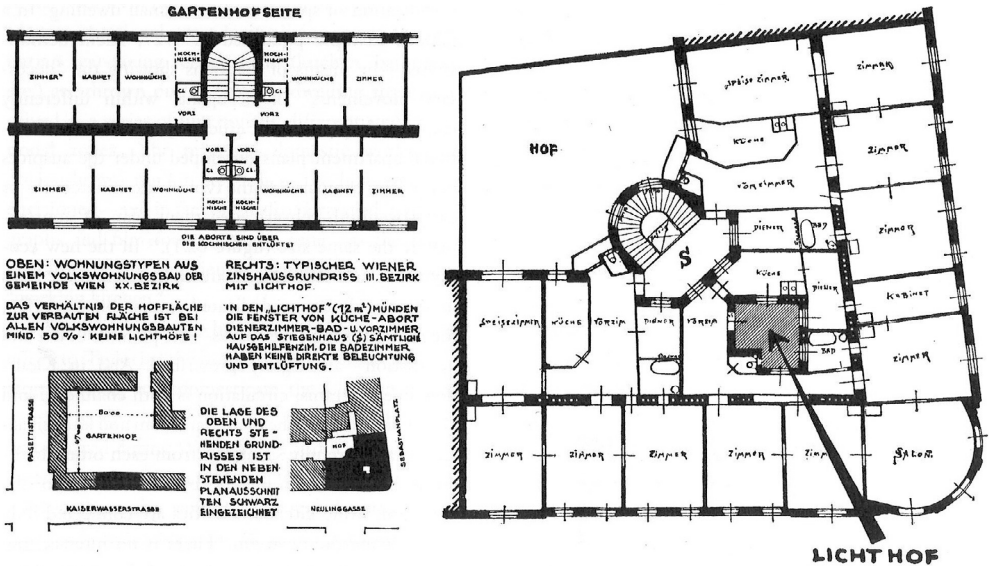

Fig. 104: The layout of municipal apartments built in Vienna in the 1920s (left) compared to typical Viennese tenements from the time before World War I with rooms facing onto a narrow air well (right), printed in *Der Aufbau* (Vienna), 1/4 (1926), p. 54. Source: Austrian National Library, 558249-C.

built using conventional construction techniques.⁴⁶⁴ The apartments, all of which were equipped with toilets and gas ovens and were almost free for working-class families, were a considerable improvement compared to the overpriced nineteenth-century tenements, where water access and toilets were located in the hallways.⁴⁶⁵ When compared with the Modernist furnished model settlements in Frankfurt am Main and Berlin, Vienna's public housing seemed modest. Yet

Fig. 104, p. 243

464 See Friedrich Achleitner: "Wiener Architektur der Zwischenkriegszeit. Kontinuität, Irritation und Resignation" [1981], in: *Wiener Architektur. Zwischen typologischem Fatalismus und semantischem Schlamassel*, Vienna: Böhlau 1996, pp. 52–72, here p. 64.

465 See Friedrich Achleitner: "Der Wiener Gemeindebau als Teil einer sozialreformerischen Konzeption. Historische, politische und wirtschaftliche Vorbedingungen" [1983], in: *Wiener Architektur. Zwischen typologischem Fatalismus und semantischem Schlamassel*, Vienna: Böhlau 1996, pp. 73–80, here pp. 73–74.

III.3.4 &
Fig. 126, p. 295

the aim of the Social Democratic city government or rather **“Red Vienna”** as a whole to improve living conditions for as many workers as possible with the funding available was certainly achieved with the new apartment blocks they built.

In his speech at the opening of the Lassalle Hof on October 3, 1926, Vienna’s mayor Karl Seitz emphasized that it was impossible to provide every working-class family with their own house in a city. Even the 290 apartments in this new municipal housing project were neither “showy” nor “excessively large,” but they went some way toward reducing the “housing shortage,” and therefore the city government would abide by this tried-and-tested concept and continue to build multistory apartment complexes with communal facilities like kindergartens and libraries.⁴⁶⁶ In the brochure to accompany the opening, the municipal planning and building office highlighted the position of the building site, which “from an urban planning perspective” had required “a particular emphasis of the architectural structure,” which the now realized project had achieved with a “tower-like development of the corner of the building.”⁴⁶⁷ The eight-story tower facing Lassallestrasse with bay windows and a top-mounted glass pavilion marks “a threshold for those who approach the city from the Reichsbrücke or those who leave it after having come from Praterstern.”⁴⁶⁸ In the specialist literature, the Lassalle Hof is also described as a “bridgehead” to the Danube and as the “entrance gate to the city.”⁴⁶⁹

For the Viennese architect Josef Frank, a vehement supporter of the settlement movement, this mixture of lower-mid-class apartments and monumental façades was fittingly

466 Cit. after “Zwei Feste der Wiener Gemeindeverwaltung,” in: *Arbeiter-Zeitung* (Vienna), October 4, 1926, p. 3 [our trans.].

467 *Lassalle-Hof. Die Wohnhausanlage der Gemeinde Wien im II. Bezirk*, ed. Wiener Stadtbauamt, Vienna: Reisser [1926], p. 5 [our trans.].

468 Friedrich Achleitner: *Österreichische Architektur im 20. Jahrhundert. Ein Führer in vier Bänden. Vol. III/1: Wien, 1.–12. Bezirk*, St. Pölten: Residenz 1990, p. 100 [our trans.].

469 Helmut Weihsmann: *Das Rote Wien. Sozialdemokratische Architektur und Kommunalpolitik 1919–1934*, 2nd ed., Vienna: Promedia 2002, p. 189 [our trans.].



Fig. 105: The Lassalle Hof in Vienna, photographed from the Lassallestrasse in 1926. Source: Municipal and Provincial Archives of Vienna, 3.3.2.FC1.407M.

expressed in the term “people’s apartment palace.”⁴⁷⁰ Instead of aiming to provide every working-class family with a house with garden, Vienna’s public housing was competing with the pathos of princely residences. As one could not directly draw on monarchical architecture as a republican, however, the “primitive-thinking planners” reverted “to medieval forms”: “castle doors, towers, bay windows, and battlements that in former times were the accessories of the ideal dwelling of the petit bourgeois, who looked to German history for inspiration.”⁴⁷¹ Indeed, the **Lassalle Hof with its mighty tower and massive portal**, its bay windows and battlements, is reminiscent

Fig. 105, p. 245

470 See Josef Frank: “Der Volkswohnungspalast / The People’s Apartment Palace,” trans. Brian Dorsey [German 1926], in: *Schriften. Bd. 1: Veröffentlichte Schriften 1910–1930. Writings. Vol. 1: Published Writings 1910–1930*, ed. Tano Bojankin, Christopher Long, and Iris Meder, Vienna: Metroverlag 2012, pp. 254–267.

471 Josef Frank: “Wiener Bauten und Wohnungen / Viennese Buildings and Apartments,” trans. Kimi Lum [German 1930], in: *Schriften. Bd. 1: Veröffentlichte Schriften 1910–1930. Writings. Vol. 1: Published Writings 1910–1930*, ed. Tano Bojankin, Christopher Long, and Iris Meder, Vienna: Metroverlag 2012, pp. 394–403, here pp. 397 and 399.

of a medieval castle in whose windows at around 3:30 p.m. on May 13, 1933, a row of mooners appeared.

With their naked buttocks, these (presumably Social Democratic- or Communist-minded) inhabitants of the Viennese public housing project wanted to offend their political opponents from Germany and deny the arriving National Socialists the authority that their supporters at the edge of the road were jubilantly asserting. However, due to the location and architecture of the Lassalle Hof, it was also a gesture of defiance aimed at invaders or besiegers: the Nazi politicians who were coming to Vienna to advocate Austria's annexation by the German Reich were supposed to be scared off and prevented from passing into the city. Yet Hans Frank drove on to the Adolf Hitler House, albeit diverted into side streets by the police at Praterstern, then went on stage that evening at the Engelmann Arena, gave a press conference the following day in the **German embassy**, and was only expelled from Austria on Monday, May 15, 1933, by order of the federal government.⁴⁷²

In order to interpret this gesture of protest appropriately, its body language must be understood. After all, in a normal stance, people's gaze would have been directed at the passing convoy. The spectators would have demonstrated their attentiveness with their eyes, ideally speaking, **marveled at the arriving princes like divine beings, or bestowed military honor on their betters**. What is the meaning of Hans Frank and his entourage instead being shown naked buttocks? Aside from the deterrent and offensive impact of the gesture, the anus also expresses a dissolution of bodily boundaries, which encapsulates Goethe's topical formulation. In the literary Götz's taunt that the captain could lick him "in" the ass, the insulter and the insulted or the besieged and the besieger merge into one, as it were. In his studies on the French writer François Rabelais, the Russian literary scholar Mikhail Bakhtin pointed out that while the eyes are of crucial significance to the body's individuality in the modern period, the grotesque body of the Renaissance emphasized its "convexities and orifices," above

472 See "Ersuchen um Rückberufung Dr. Franks," in: *Reichspost* (Vienna), May 16, 1933, p. 1.

all the mouth and the nose, the phallus and the buttocks.⁴⁷³ In this sense, the Viennese mooners of May 13, 1933, not only called into question the authority of the German Nazi politicians, but also “the individual, strictly limited mass, the impenetrable façade” of the modern body.⁴⁷⁴

473 Mikhail Bakhtin: *Rabelais and His World*, trans. Helene Iswolsky, Bloomington: Indiana University Press 1984 [Russian 1965], pp. 316–317.

474 Bakhtin: *Rabelais and His World*, p. 320.

How to Speak Up: Governed Transmissions

SPACE	UNLIMITED
TIME	FINITE
VALUE	DISTRIBUTED
PERSPECTIVE	STREET VIEW
NAVIGATION	TRACKING

RADIO

3.1

The “Turks Deliverance Celebration,” held by the Austrian Homeland Protection in the gardens of Schönbrunn Palace on May 14, 1933, was aired on *Radio Wien* from 10:20 to 11:05 a.m. How did this live broadcast work in technical terms?

STATISTICS

3.2

The live broadcast of the “Turks Deliverance Celebration” on *Radio Wien* not only contradicted the guidelines of the Austrian Radio Verkehrs AG, but also went against the wishes of the audience as statistically surveyed by a research group under the direction of Paul Lazarsfeld in 1931/32.

Fig. 106: The distributed network of the mediation “How to Speak Up: Governed Transmissions” in the Topology module of the website *campusmedius.net* (version 2.0/2021), designed by Susanne Kiesenhofer and adapted for the book edition by Stefan Amann.

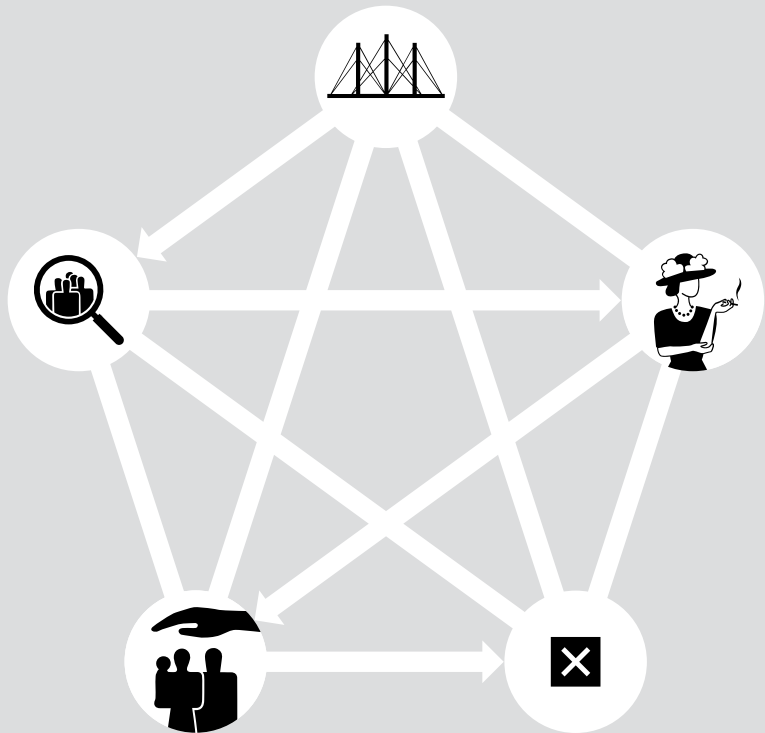

MARKETING

3.3

Is it a coincidence that the Vienna *Neue Freie Presse* printed an essay about Edward Bernays's public relations on the day of the “Turks Deliverance Celebration”? Probably so, but parallels between the political rally and his PR techniques are still discernible.

WELFARE

3.4

What were the Social Democrats doing on the weekend of the “Turks Deliverance Celebration,” that is, the political party that had been ruling Vienna with an outright majority since 1919? They organized “freedom celebrations” in the municipal housing projects, among them the Karl Marx Hof.

CANCELLATION

3.5

In protest against the live broadcast of the “Turks Deliverance Celebration” on *Radio Wien* on May 14, 1933, the Social Democratic Workers' Party arranged a “listener strike”: thousands of listeners canceled their license at the Austrian radio company.

3.1 Radio: Mikes, Cables, Transmitters



place	Schönbrunn Palace gardens
moment	Live broadcast on the radio
space	0
time	0

- II.10 In the photographs and film recordings of the speeches held during the “**Turks Deliverance Celebration**” (*Türkenbefreiungsfeier*) in Schönbrunn Palace gardens on May 14, 1933, a row of microphones can be seen. Their stands, down which the connector cables coil, are arranged in a semicircle around a wooden podium on the garden terrace of the palace building. There are **six microphones** in total, two of which are mounted right above one another, and they are pointed at the speakers roughly at face level. Why half a dozen? While it is only possible to surmise which specific microphone was used for which purpose, their number is explained by the different transmission and recording channels. Besides being transmitted via public-address system in the palace park, the speeches were also recorded by two newsreel teams, broadcast live on *Radio Wien*, and probably also captured on records or in optical sound format by Austrian radio and by the Homeland Protection League (*Heimatschutzverband*).
- II.13

- III.1.3 Clearly identifiable in the surviving pictures of the “Turks Deliverance Celebration” are two carbon microphones by Eugen Reisz from Berlin—the so-called Reisz microphone in a white marble block, which was used from the mid-1920s both for radio and for public addresses. Loudspeakers must have been in operation at the mass rally in the **gardens of Schönbrunn Palace** on May 14, 1933, because otherwise hardly any of the Home Guard (*Heimwehr*) members standing in the parterre or in the avenues would have been able to hear the speeches. In a brochure on preparing for the event, it says:



Fig. 107: Engelbert Dollfuß (at the microphones) and Ernst Rüdiger Starhemberg (behind him) on the garden terrace of Schönbrunn Palace in Vienna at the “Turks Deliverance Celebration” on May 14, 1933 (numbers added): ① carbon microphone (model unknown); ② dynamic microphone (probably a Western Electric 618A); ③ carbon microphone (Reisz); ④ carbon microphone (Reisz) and above it a dynamic microphone (model unknown); ⑤ possibly a microphone by the Selenophon Licht- und Tonbild GmbH.
Source: Austrian National Library, 106.661 B

“All commands will be given via loudspeaker.”⁴⁷⁵ In addition, the Palace Captainship (*Schlosshauptmannschaft*) Schönbrunn subsequently invoiced the Austrian Homeland Protection as the event organizer thirteen kilowatt hours at fifty-seven groschen each, in other words a total of 7.41 schillings for the electricity used by the “loudspeaker system.”⁴⁷⁶ Furthermore, on the left edge of a **panorama** of the “Turks Deliverance Celebration,” part of a podium or truck marked “[Laut]sprecher” (“[loud]speaker”) has been captured.

Fig. 56, p. 143

475 Arthur Karg-Bebenburg: *Weisungen für die Türkenbefreiungs-Gedenkfeier am 14. Mai 1933 in Wien*, Vienna: Österreichischer Heimatschutzverband 1933, p. 9 [our trans.].

476 See letter incl. statement of costs from the Palace Captainship Schönbrunn to the Austrian Homeland Protection, dated April 29, 1933, in the Austrian State Archives (ÖStA/AdR, SHS 820/1933, Kt. 86) [our trans.].

Fig. 107, p. 251

What exact kind of public-address system was installed in Schönbrunn Palace gardens on May 14, 1933, is documented neither in archives nor by the media of the time. The New York company Western Electric had patented a centralized “Loud Speaking Public Address System” in 1922.⁴⁷⁷ It is quite conceivable that a speaker tower along these lines was set up at the “Turks Deliverance Celebration.” After all, the company in Vienna that specialized in electroacoustic tasks, namely Czeija, Nissl & Co., was a subsidiary of Western Electric.⁴⁷⁸ Moreover, a dynamic microphone **mounted on the speaker’s podium** closely resembles the models produced by Western Electric from the early 1930s, e.g., the moving-coil microphone 618A. The American company’s products were also used via Czeija, Nissl & Co. by Austrian radio, called Radio Verkehrs AG (RAVAG),⁴⁷⁹ which equipped its reporters with buttonhole microphones by Western Electric in spring 1933, for example.⁴⁸⁰

Also strongly represented in Vienna were the German electric companies. Siemens & Halske sold a range of dynamic loudspeakers around 1930, including the large “Riesenblatt-haller,” which was primarily suited for transmitting public addresses centrally, from a single position.⁴⁸¹ In the early 1930s, Siemens and the Allgemeine Electricitäts-Gesellschaft (AEG) transferred their electroacoustic departments to their subsidiary Telefunken, which in this line of business specialized in decentralized public-address systems. In 1932, for example, Telefunken equipped Vienna’s St. Stephen’s Cathedral with dynamic microphones, as well as eleven loudspeakers mounted in the nave.⁴⁸² On May 1, 1933, the company was responsible

477 See Ralf Gerhard Ehlert: “Public-Address-Strategien von 1919 bis 1949,” in: Daniel Gethmann and Markus Stauff (eds.): *Politiken der Medien*, Zurich/Berlin: diaphanes 2005, pp. 319–340, here p. 324.

478 See Reinhard Schlögl: *Oskar Czeija. Radio- und Fernsehponier, Unternehmer, Abenteurer*, Vienna: Böhlau 2005, p. 36.

479 See Viktor Ergert: *50 Jahre Rundfunk in Österreich. Vol. I: 1924–1945*, Vienna: Residenz 1974, p. 56.

480 See “Der entfesselte Radioreporter,” in: *Radiowelt* (Vienna), 10/25 (June 17, 1933), p. 795.

481 See Ehlert: “Public-Address-Strategien von 1919 bis 1949,” p. 328.

482 See Karl Dobsch: “Lautsprecher im Stephansdom,” in: *Radiowelt* (Vienna), 9/20 (May 14, 1932), pp. 620–621.

for the public-address system used at the Nazi celebration for the “Day of National Work” on Tempelhofer Feld in Berlin, where echo effects disrupted the acoustic quality. Hence in the following year, Telefunken presented the “mushroom loudspeaker” (*Pilzlautsprecher*) which emitted sound uniformly in a circle and went on to be used at a number of future Nazi rallies with distributed-element circuits.⁴⁸³

Whereas at the “Turks Deliverance Celebration” on May 14, 1933, central speakers were presumably used to the left and right of the palace terrace, four months later Czeija, Nissl & Co. installed a multipart public-address system with forty-eight electrodynamic loudspeakers in the same venue, Schönbrunn Palace gardens, which were mounted on flagpoles in the Great Parterre, on trees in the avenues, and on the balcony of the palace itself. This electroacoustic installation facilitated a Catholic Mass with some 300,000 participants, which took place in the context of the General German Catholic Congress on September 10, 1933. The voices of the speakers and choir were transmitted from the altar on the palace terrace via dynamic and carbon microphones; the peals came from a phonograph attached to an amplifier, which played the bells of St. Stephen’s Cathedral on records.⁴⁸⁴

Due to the connections between Czeija, Nissl & Co. and Western Electric, it is therefore possible that the aforementioned moving-coil microphone captured in some photographs of the “Turks Deliverance Celebration” was part of the public-address system. However, the carbon microphones in front of the speaker’s podium would also have been suitable for this purpose, one of the two Reisz models, for instance, whose noise floor would have been less noticeable in the loudspeakers in the palace park than in the sound film recording, for which

483 See Ehlert: “Public-Address-Strategien von 1919 bis 1949,” pp. 330–332, and Cornelia Epping-Jäger: “‘Eine einzige jubelnde Stimme.’ Zur Etablierung des Dispositivs Laut/Sprecher in der politischen Kommunikation des Nationalsozialismus,” in: Cornelia Epping-Jäger and Erika Linz (eds.): *Medien/Stimmen*, Cologne: DuMont 2003, pp. 100–123, here pp. 106–114 and 117–118.

484 See Ferdinand Rakuschan: “Die Andacht der Dreihunderttausend,” in: *Radiowelt* (Vienna), 10/46 (November 11, 1933), pp. 1508–1509.

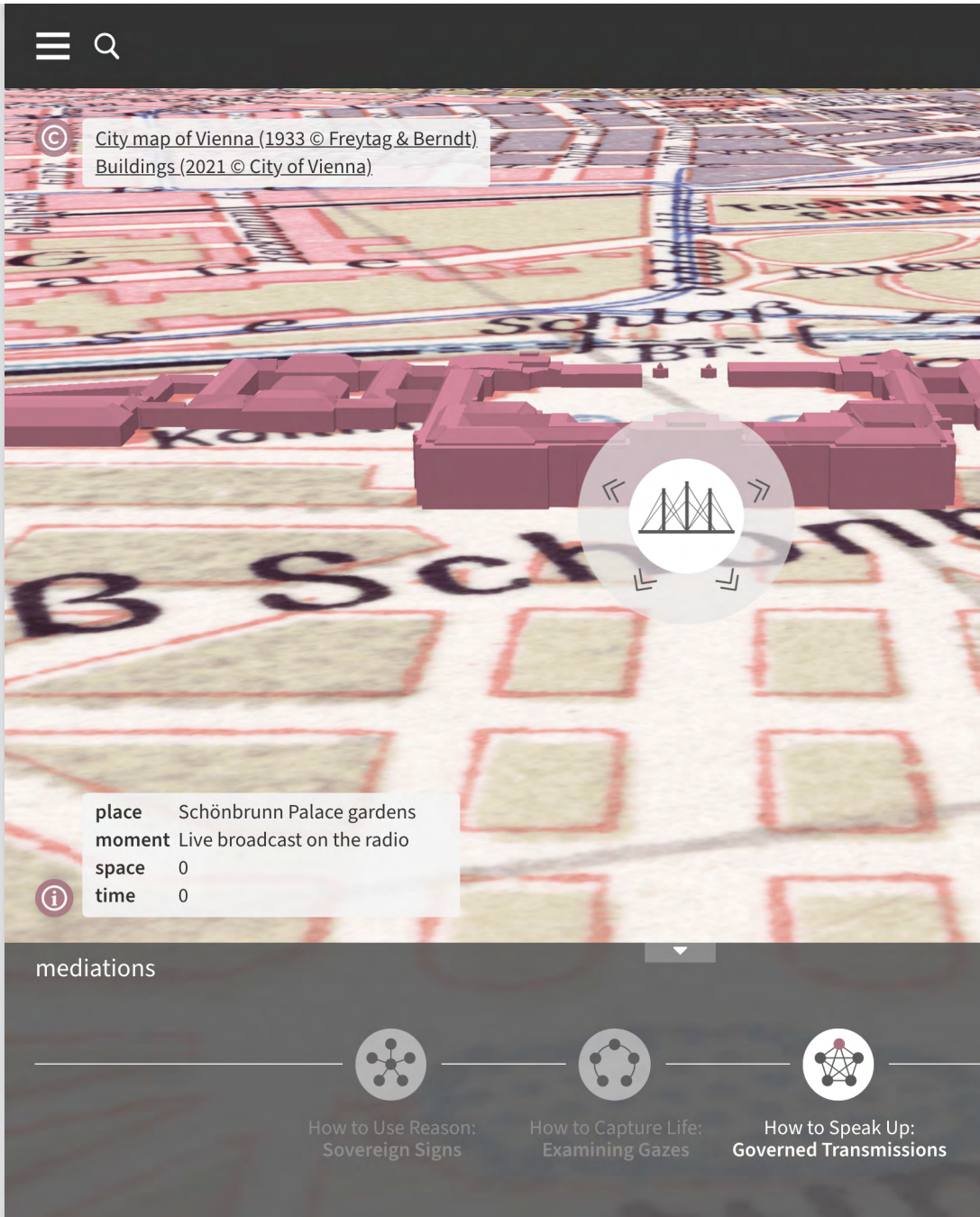

Fig. 108: Screenshot of the Topology module of the website campusmedius.net (desktop version 2.0/2021) showing the abstract of the mediator “Mikes, Cables,

How to Speak Up: Governed Transmissions

RADIO

Mikes, Cables, Transmitters

The "Turks Deliverance Celebration," held by the Austrian Homeland Protection in the gardens of Schönbrunn Palace on May 14, 1933, was aired on *Radio Wien* from 10:20 to 11:05 a.m. How did this live broadcast work in technical terms?

READ MORE

Transmitters" in the mediation "How to Speak Up: Governed Transmissions" (text: Simon Ganahl, code: Andreas Krimbacher, design: Susanne Kiesenhofer).

III.2.2

dynamic microphones were usually used.⁴⁸⁵ In any case, it is a fact that a piece in the *Fox Tönende Wochenschau* newsreel, whose American production company was also linked with Western Electric by patent law,⁴⁸⁶ covered the “Turks Deliverance Celebration.”⁴⁸⁷ The corresponding recording van stood between the Home Guard members in the parterre: a **35 mm film camera by Bell & Howell** was positioned on the vehicle’s roof and the apparatus for recording the optical sound was located inside the vehicle, from which a cable led to the microphone on the palace terrace.

A couple of steps away from this black sedan, which belonged to either *Fox Movietone News* or a freelance cameraman, stood the truck of Selenophon Licht- und Tonbild GmbH, whose film studio was located nearby, namely at Maxingstrasse 13a on the western edge of Schönbrunn Palace gardens. The Viennese company had developed its own optical sound method in the 1920s and had been producing newsreels since 1930, initially under the company name, then for Hugo Engel Film GmbH, and from spring 1933 the company was commissioned with the propagandistic *Österreich in Bild und Ton* (“Austria in Image and Sound”) by the Federal Chancellery.⁴⁸⁸ In contrast to the piece by Fox, these recordings of the “Turks Deliverance Celebration” from May 14, 1933, have not survived but the **photographed vehicle** is undoubtedly Selenophon’s “traveling sound film studio,” which was equipped with “all the feats of

Fig. 56, p. 143

485 See Alfred Koblmüller: “Über Mikrophone und ihre Besprechungstechnik,” in: *Radiowelt* (Vienna), 8/45 (November 7, 1931), pp. 1458–1461.

486 See Olaf Schumacher and Hans Jürgen Wulff: “Warner, Fox, Tobis-Klangfilm und die Anfänge des Tonfilms,” in: Joachim-Felix Leonhard et al. (eds.): *Medienwissenschaft. Ein Handbuch zur Entwicklung der Medien und Kommunikationsformen*, vol. 2, Berlin/New York: Walter de Gruyter 2001, pp. 1198–1207, here p. 1201.

487 See “Die Türkenbefreiungsfeier des österreichischen Heimatschutzes in Wien,” in: *Jahresschau 1933 der Bundespolizeidirektion in Wien. Eine Chronik im Laufbild*, 35 mm film, source: Filmarchiv Austria, JS 1933/8, and *Österreichische Film-Zeitung* (Vienna), 7/20 (May 20, 1933), p. 6.

488 See Armin Loacker: “Privater Staatsbetrieb. Anmerkungen zu einer Entwicklungsgeschichte der Selenophon,” in: Hrvoje Milostavic (ed.): *Die Ostmark-Wochenschau. Ein Propagandamedium des Nationalsozialismus*, Vienna: Filmarchiv Austria 2008, pp. 46–69, here pp. 61–65.

modern sound film technology and electroacoustics.”⁴⁸⁹ The equipment also included a heptagonal microphone hung in a metal frame, which might be the same as the model **that stood between the two Reisz blocks on the palace terrace.**

Fig. 107, p. 251

Selenophon GmbH was founded in 1928 by Oskar Czeija, whose father had established Czeija, Nissl & Co. in the nineteenth century but had sold his shares in the early twentieth century.⁴⁹⁰ His son was never involved in this telephone and telegraph factory, but he played a key role at the Radio Verkehrs AG, which was constituted in 1924 and which he ran from the outset as its general manager.⁴⁹¹ The Selenophon optical sound system was developed by Czeija in collaboration with the Viennese physicist Hans Thirring and some RAVAG employees.⁴⁹² Therefore, it is unsurprising that the apparatuses produced by the company were used on Austrian radio. In the RAVAG’s recording van, which was set up in the early 1930s and was somewhat erroneously called “**transmitter car**” (*Übertragerauto*), it was not only possible to record the original sound on wax and gelatin records; it was also furnished with Selenophon’s professional **U7 tape recorder**, which could record and play optical sound on celluloid or paper film.⁴⁹³ After development, the six-millimeter-wide film—in contrast to records—could be cut and stuck back together at will, i.e., **edited as in the process of film production.** Consequently, this method was suitable not only for archiving sound, but above all for compiling longer audio features.

Fig. 109, p. 258

Fig. 110, p. 258

III.2.3

It is probable that the RAVAG’s recording van was present at the “Turks Deliverance Celebration,” though actual evidence is lacking. In the Österreichische Mediathek, an Austrian archive

489 “Wie die Tonfilmwochenschau entsteht,” in: *Mikrophon* (Vienna), 1/1 (February 1934), pp. 47–49, here p. 48 [our trans.].

490 See Schlögl: *Oskar Czeija*, p. 36.

491 See Wolfgang Pensold: *Zur Geschichte des Rundfunks in Österreich. Programm für die Nation*, Wiesbaden: Springer 2018, pp. 1–6.

492 See Josef Gloger: “Die österreichische Selenophon Licht- und Tonbildges. m.b.H.,” in: Michael Achenbach and Karin Moser (eds.): *Österreich in Bild und Ton. Die Filmwochenschau des austrofaschistischen Ständestaates*, Vienna: Filmarchiv Austria 2002, pp. 149–160.

493 See “Rundfunksendungen auf Tonstreifen,” in: *Radio Wien* (Vienna), 13/13 (December 25, 1936), pp. 2–3.

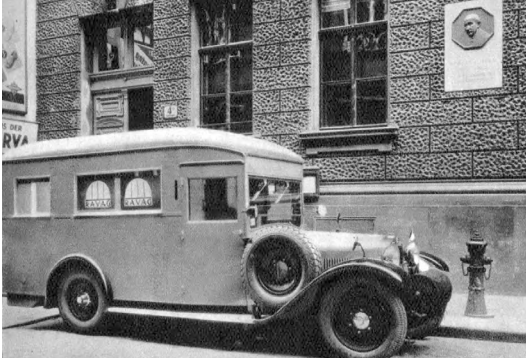

Fig. 109: Recording van of the Austrian Radio Verkehrs AG, called “transmitter car” (*Übertragerauto*), printed in *Radio Wien* (Vienna), 11/1 (September 28, 1934), p. 22. Source: Austrian National Library, 607949-C.

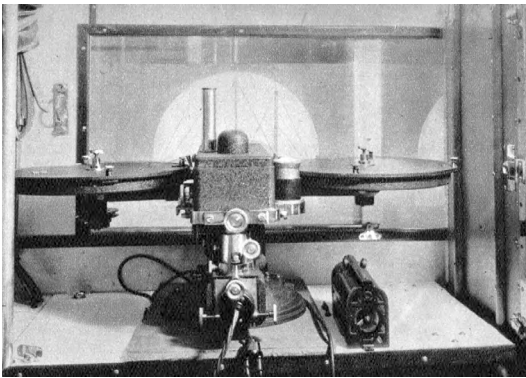

Fig. 110: The U7 device for recording optical sound, produced by the Viennese Selenophon GmbH, in the “transmitter car” (*Übertragerauto*) of the Austrian Radio Verkehrs AG, printed in *Radio Wien* (Vienna), 11/1 (September 28, 1934), p. 23. Source: Austrian National Library, 607949-C.

Fig. 107, p. 251

III.1.5

for sound recordings, a segment of the speech held by Federal Chancellor **Engelbert Dollfuss** at the rally in Schönbrunn Palace gardens on May 14, 1933, has been preserved.⁴⁹⁴ Assembled from an announcement, part of his speech, and the **national anthem**, the document’s origin is uncertain but it is congruent with the optical soundtrack of the aforementioned piece in the *Fox Tönende Wochenschau*, for which reason it can be presumed that the recording comes from this 35 mm film and not from a record or a cine film by the RAVAG. What is certain is that *Radio Wien* reported live from the event from 10:20 to 11:05 a.m. It appears to have been a spontaneous decision, because although the live broadcast was announced in some daily newspapers, it was not mentioned in the listings magazines

494 See “Engelbert Dollfuss anlässlich einer Feier zur Erinnerung an die Befreiung Wiens von den Türken” (Vienna, May 14, 1933), CD, source: Österreichische Mediathek, 8-29501_b02.

III.1.1

that were published weekly.⁴⁹⁵ Judging by the schedule of events at the “Turks Deliverance Celebration,” the speeches by Security Minister Emil Fey, by **Ernst Rüdiger Starhemberg**, the federal leader of the Austrian Homeland Protection, and by Dollfuss were broadcast, and possibly also parts of the field Mass read from 10 a.m.⁴⁹⁶ It is also conceivable that a RAVAG reporter conducted interviews with the guests at the celebration or the Home Guard members in the Great Parterre in addition to moderating the event.⁴⁹⁷

Fig. 107, p. 251

Fig. 111, p. 260

How did this radio broadcast work from a technical perspective? Although the RAVAG also used ribbon and condenser microphones around 1933, the carbon microphone by Reisz had been in regular use at *Radio Wien* since 1925.⁴⁹⁸ It can therefore be assumed that one of the two models documented in the **photographs** of the “Turks Deliverance Celebration” served the live broadcast. In the **marble block of the Reisz microphone**, there was a hole filled with carbon granules, over which there lay a rubber membrane. Electricity was transmitted through the granules via electrodes, with the resistance changing due to speech hitting the membrane. The varying electricity caused by the sound waves could then be transmitted to an amplifier by a transformer.⁴⁹⁹ The microphone was connected to the tube amplifier by cable, but how did the voices that had been transformed into electricity reach the radio transmitter?

Fig. 112, p. 261

The RAVAG had owned a “**shortwave broadcaster car**” (*Kurzwellen-Senderauto*) since 1929, which unlike the later recording

495 See, for example, “Radio-Wochenprogramm vom 13. bis 21. Mai,” in: *Neue Freie Presse* (Vienna), May 13, 1933 (evening edition), p. 4, vs. “Sonntag, 14. Mai,” in: *Radio Wien* (Vienna), 9/33 (May 12, 1933), pp. 31–38, here p. 31.

496 See Karg-Bebenburg: *Weisungen für die Türkenbefreiungs-Gedenkfeier am 14. Mai 1933 in Wien*, p. 3, and a report by the Federal Police Headquarters in Vienna from May 15, 1933, in the Austrian State Archives (ÖStA/AdR, BKA-I, 148.459/33).

497 A newspaper article following the live broadcast mentions a “reportage by the RAVAG speaker,” see “Die Ravag mit dem Hahnenschwanz,” in: *Das Kleine Blatt* (Vienna), May 16, 1933, p. 9 [our trans.].

498 See Gustav Schwaiger: “Technischer Rück- und Ausblick,” in: *Radio Wien* (Vienna), 11/1 (September 28, 1934), pp. 19–25, here pp. 23–24.

499 See Horst Tischner: “Das Reiss-Mikrophon,” in: Fritz Fischer and Hugo Lichte (eds.): *Tonfilm. Aufnahme und Wiedergabe nach dem Klangfilm-Verfahren (System Klangfilm-Tobis)*, Leipzig: Hirzel 1931, pp. 170–171.

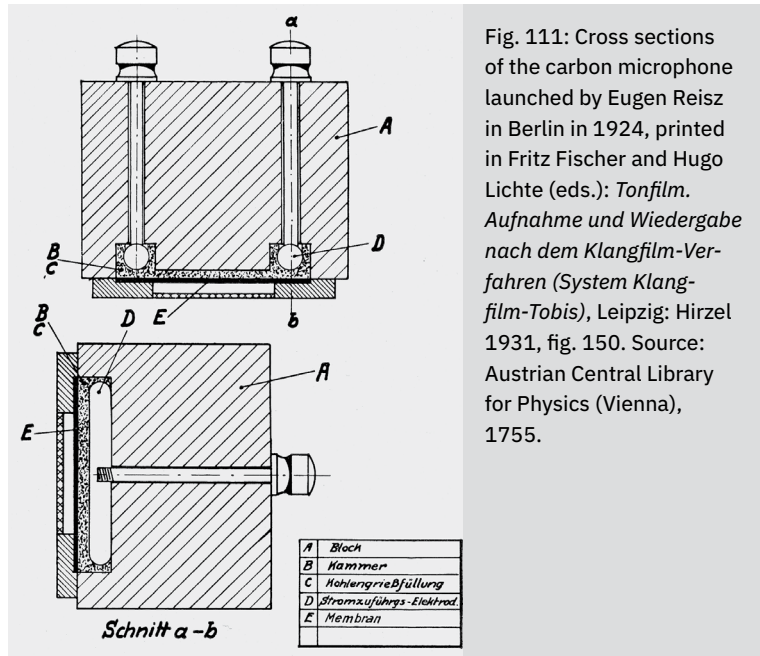

Fig. 111: Cross sections of the carbon microphone launched by Eugen Reisz in Berlin in 1924, printed in Fritz Fischer and Hugo Lichte (eds.): *Tonfilm. Aufnahme und Wiedergabe nach dem Klangfilm-Verfahren (System Klangfilm-Tobis)*, Leipzig: Hirzel 1931, fig. 150. Source: Austrian Central Library for Physics (Vienna), 1755.

Fig. 113, p. 261

van, the “transmitter car,” was equipped for wireless radio transmissions. In this actual broadcasting van, called an OB van, a **shortwave transmitter** had been installed whose range theoretically covered the whole of Europe.⁵⁰⁰ In professional radio operations, however, it was only possible to guarantee a radius of ten to fifteen kilometers.⁵⁰¹ It would have been quite possible to wirelessly transmit the speeches held on the periphery in Schönbrunn to the RAVAG headquarters in Vienna city center via shortwaves in order to then transmit the broadcasts from there via radio cables. However, the shortwave broadcaster car was used from 11:05 a.m., i.e., immediately after the broadcast of the “Turks Deliverance Celebration,” for a live report on a relay race and **photographed doing so on the race track in the Prater park**.⁵⁰² As Schönbrunn is in the southwest of Vienna but the Prater in the northeast, the OB

Fig. 32, p. 89

500 See Gustav Schwaiger: “Die Bedeutung der Kurzwellen für den Rundfunk,” in: *Radiowelt* (Vienna), 9/23 (June 4, 1932), pp. 710 and 735.

501 See Ergert: *50 Jahre Rundfunk in Österreich*, pp. 109–111 and 116–117.

502 See “Radio-Wochenprogramm vom 13. bis 21. Mai,” in: *Neue Freie Presse* (Vienna), May 13, 1933 (evening edition), p. 4, and “Das Mikrophon berichtet,” in: *Radio Wien* (Vienna), 9/34 (May 19, 1933), p. 2.

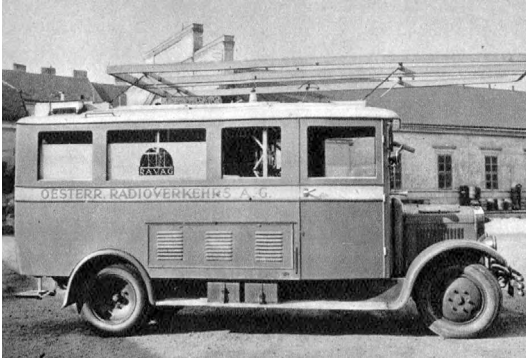

Fig. 112: The “shortwave broadcaster car” (*Kurzwellen-Senderauto*) of the Austrian Radio Verkehrs AG, printed in *Radio Wien* (Vienna), 11/1 (September 28, 1934), p. 22. Source: Austrian National Library, 607949-C.

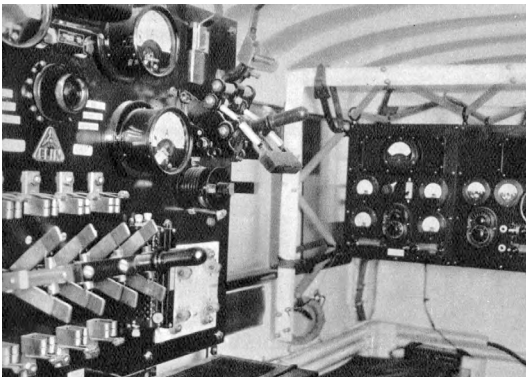

Fig. 113: The shortwave transmitter in the “broadcaster car” (*Senderauto*) of the Austrian Radio Verkehrs AG, printed in *Radio Wien* (Vienna), 11/1 (September 28, 1934), p. 22. Source: Austrian National Library, 607949-C.

van cannot have been used in both places as there was simply not enough time for it to travel from one location to the other.

Perhaps one of the transportable shortwave transmitters, which were also in operation at the RAVAG from 1929,⁵⁰³ was used to broadcast the “Turks Deliverance Celebration.” However, it is more probable that the live broadcast was simply transmitted via telephone cable from Schönbrunn Palace to Johannesgasse 4 in Vienna’s first district, where the broadcasting center had been located since 1926. In the two years prior to this, *Radio Wien* had been housed on the top floor of the army ministry on Stubenring. Initially the RAVAG also broadcast from there before erecting a radio transmitter by Telefunken on the Rosenhügel, a hill in the southwest of Vienna, in 1925 whose capacity was increased from seven to

503 See Ergert: *50 Jahre Rundfunk in Österreich*, pp. 109–111 and 116–117.

Fig. 114, p. 262

the north of Vienna. Again by Telefunken, this system had a transmitting capacity of one hundred kilowatts and had been in trial operation since early May.⁵⁰⁶ Due to Austria's elongated, partly mountainous terrain, even this transmitter was not capable of sending its radio waves to all parts of the country at the strength required for radio reception, and much less its predecessor on the Rosenhügel, which probably transmitted the "Turks Deliverance Celebration." For that reason, since the mid-1920s **radio cables** had been laid from the capital city in the far east to the west and south of Austria and several relay stations had been built.⁵⁰⁷ That means that the alternating currents in this specific case, the live broadcast from 10:20 to 11:05 a.m. on May 14, 1933, were not only relayed by radio cable to the Rosenhügel after presumably arriving at the RAVAG headquarters via telephone connection from Schönbrunn Palace, but also to the regional transmitters in Graz, Linz, Klagenfurt, Salzburg, and Innsbruck, which produced electromagnetic waves at the respectively assigned frequency or length and broadcast it in the provinces. To the chagrin of the residents of Vorarlberg, the westernmost part of Austria, who had complained about the poor reception of *Radio Wien* for a decade, the transmitter in the town Lauterach was only completed in late 1934.⁵⁰⁸

- 506 See "Probesendungen am Bisamberg," in: *Radiowelt* (Vienna), 10/19 (May 6, 1933), p. 582.
- 507 See Schwaiger: "Die bisherige Entwicklung der technischen Einrichtungen der 'Ravag,'" pp. 55–61.
- 508 See Pensold: *Zur Geschichte des Rundfunks in Österreich*, p. 57.

3.2 Statistics: RAVAG Studies



place	RAVAG headquarters
moment	Results of audience survey
space	5 km 2 m away
time	191 d 4 h 20 min earlier

- II.10 The “**Turks Deliverance Celebration**” (*Türkenbefreiungsfeier*), which was held by the Austrian Homeland Protection (*Heimatschutz*) in the gardens of Schönbrunn Palace on May 14, 1933,
- II.13 was transmitted on *Radio Wien* from 10:20 to 11:05 a.m.⁵⁰⁹ This
- III.3.1 **live broadcast** went against the programming guidelines of the Austrian Radio Verkehrs AG (RAVAG), which had been bound by political neutrality since its founding in 1924. From a legal perspective, it was a private corporation, despite the majority of the company’s shares being owned by state- or party-affiliated organizations. There was party-political proportional representation on the supervisory boards and in the workforce; in addition, an advisory council with representatives of the provinces, the professional chambers, the economy, and the amateur radio clubs was intended to ensure balanced programming.⁵¹⁰ In the role of general manager was Oskar Czejja, a trained lawyer and former civil servant who had been working toward the creation of an Austrian radio station since 1920 and knew how to pursue his entrepreneurial interests with ideological flexibility.⁵¹¹ The result of this party-political superstructure above the RAVAG was programming on *Radio Wien* that disregarded politics and religion in favor of education and sophisticated entertainment.

The “Turks Deliverance Celebration” was officially organized to commemorate the liberation of Vienna from its siege

509 See “Radio-Wochenprogramm vom 13. bis 21. Mai,” in: *Neue Freie Presse* (Vienna), May 13, 1933 (evening edition), p. 4.

510 See Viktor Ergert: *50 Jahre Rundfunk in Österreich. Vol. I: 1924–1945*, Vienna: Residenz 1974, pp. 45–46.

511 See Wolfgang Pensold: *Zur Geschichte des Rundfunks in Österreich. Programm für die Nation*, Wiesbaden: Springer 2018, pp. 1–6.

Fig. 107, p. 251

by Ottoman troops in 1683. However, these historical events merely served as a pretense for the speakers to discuss current political issues. This is clearly shown by a short excerpt of Engelbert **Dollfuss's address**, which is archived in the Österreichische Mediathek, an Austrian archive for sound recordings:

*When you celebrate this day and this period today, it is not an ordinary reminder of history. Foreign spirit and foreign ideas are in our people, have infected our people, and wreaked evil havoc. [Boos] In the fight for our homeland, in the fight for the improvement of our home country, we remain determinedly and devotedly united.*⁵¹²

III.3.4 With “foreign spirit,” the federal chancellor was referring to socialist ideology: on the one hand the politics of Austrian Social Democracy, which were implemented primarily in “**Red Vienna**,” and on the other the National Socialists, who had been ruling Germany since late January 1933 and were also threatening to take over power in Austria. Dollfuss had already declared on *Radio Wien* on March 13 that there was not a national crisis but a parliamentary crisis, and his government was implementing ongoing resolutions via emergency decree until a new constitution organized around professions had been finalized.⁵¹³ Subsequently, the members of the federal government were regularly given the chance to speak on *Radio Wien*. From April the **national anthem** was played at the end of each day’s broadcasts, and the first program in the series “Homeland Hour” (*Stunde der Heimat*) on May 16—two days after the “Turks Deliverance Celebration”—was dedicated to the topic “1683 in the fate of Austria and Germany.”⁵¹⁴

III.1.5

General Manager Czeija and his employees submitted to this authoritarian course and designed a program of radio shows from spring 1933 that met the federal government’s

512 Cit. after the sound recording “Engelbert Dollfuss anlässlich einer Feier zur Erinnerung an die Befreiung Wiens von den Türken” (Vienna, May 14, 1933) [our trans.], CD, source: Österreichische Mediathek, 8-29501_b02.

513 See “Was jetzt? Rundfunkrede des Bundeskanzlers,” in: *Reichspost* (Vienna), March 14, 1933, p. 5.

514 See “Was gibt’s Neues im Äther?,” in: *Radiowelt* (Vienna), 10/14 (April 1, 1933), p. 423, and “Heimatsdienst im Rundfunk,” in: *Radiowelt* (Vienna), 10/19 (May 6, 1933), p. 582 [our trans.].

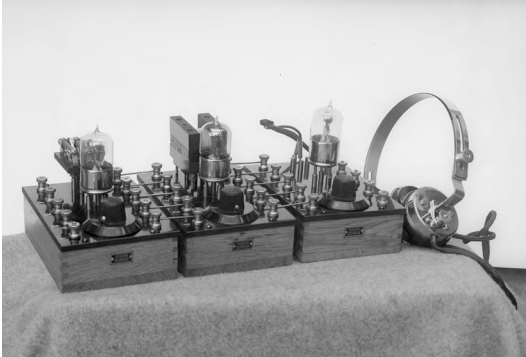

Fig. 115: Radio set with three tubes and headphones produced by the Viennese company Schrack around 1925. Source: Austrian National Library, L 15.914-C.

demands but in large part flew in the face of public wishes. In actual fact, the majority of listeners wanted to be neither intellectually nor politically educated by the radio, but rather above all to be entertained by it. As early as December 1924, three months after the RAVAG had started broadcasting, the Vienna *Radiowelt* asked its readers: “What do you want to hear?” and summarized the results of the survey in keywords in May 1925: “No politics, no stock market, no sermon!”⁵¹⁵ Three years later Franz Anderle, the editor of this radio magazine, wrote a leading article in which he called on the Viennese broadcaster to have a statistical study conducted of the wishes and composition of its audience.⁵¹⁶

In 1931 the RAVAG finally responded to the challenge—posed not only by *Radiowelt*—to investigate their listeners’ likes and dislikes with a series of surveys conducted in cooperation with the Department of Psychology at the University of Vienna. It started with a musical request program with almost 50,000 votes cast, which revealed that Johann Strauss was the most popular composer and his waltz *The Blue Danube* the most requested piece.⁵¹⁷ This was followed by an experiment whereby listeners had to guess the appearance and profession of nine men, women, and adolescents whose voices were

- 515 See “Was wünschen Sie zu hören?” in: *Radiowelt* (Vienna), 1/41 (December 13, 1924), p. 7 [our trans.], and “Sie haben gesprochen!,” in: *Radiowelt* (Vienna), 2/19 (May 9, 1925), pp. 1–2, here p. 1 [our trans.].
- 516 See “Für wen sendet Radio-Wien?,” in: *Radiowelt* (Vienna), 5/17 (April 28, 1928), p. 1.
- 517 See “Das Wunschkonzert der RAVAG: Johann Strauss hat gesiegt,” in: *Radio Wien* (Vienna), 7/20 (February 13, 1931), p. 1.

broadcast over the radio.⁵¹⁸ Another survey, which focused on the reasons for canceling RAVAG licenses, came to the conclusion that almost half of the former listeners were obliged to do so for financial reasons.⁵¹⁹ When one considers that a factory worker in Vienna earned approximately sixty schillings a week at the time, the monthly radio license fee of two schillings may seem affordable. However, the simple crystal receivers with headphones from the first years of radio were followed by **tube sets with loudspeaker**, which had already become



Fig. 116: Radio set with six tubes and loudspeaker by the brand Berliner from 1933. Source: Austrian National Library, 223.153-B.

Fig. 116, p. 267

established around 1930 and whose entry-level models complete with accessories cost some hundred schillings.⁵²⁰

The series of studies culminated in a large-scale listener survey whose questionnaire was enclosed in radio magazines and displayed in tobacco shops in November 1931 and had to be returned to the RAVAG headquarters at Johannesgasse 4 in Vienna by December 1.⁵²¹ The scientific management of the project was once again taken over by the Department of Psychology at the University of Vienna, which was opened in 1922 and whose chair was held by Karl Bühler, who had doctorates in medicine and philosophy. At the department there

- 518 See Paul Lazarsfeld: "Was erraten wir aus der menschlichen Stimme?" in: *Radio Wien* (Vienna), 7/36 (June 5, 1931), pp. 9–11; Paul Lazarsfeld: "Was erraten wir aus der menschlichen Stimme?" in: *Radio Wien* (Vienna), 7/45 (August 7, 1931), pp. 4–5.
- 519 See Lotte Radermacher: "Warum Hörer ihre Teilnehmerschaft aufgeben," in: *Radio Wien* (Vienna), 7/47 (August 21, 1931), p. 3.
- 520 See Pensold: *Zur Geschichte des Rundfunks in Österreich*, pp. 11–12.
- 521 See "Hörerbefragung," in: *Radio Wien* (Vienna), 8/7 (November 13, 1931), p. 1.

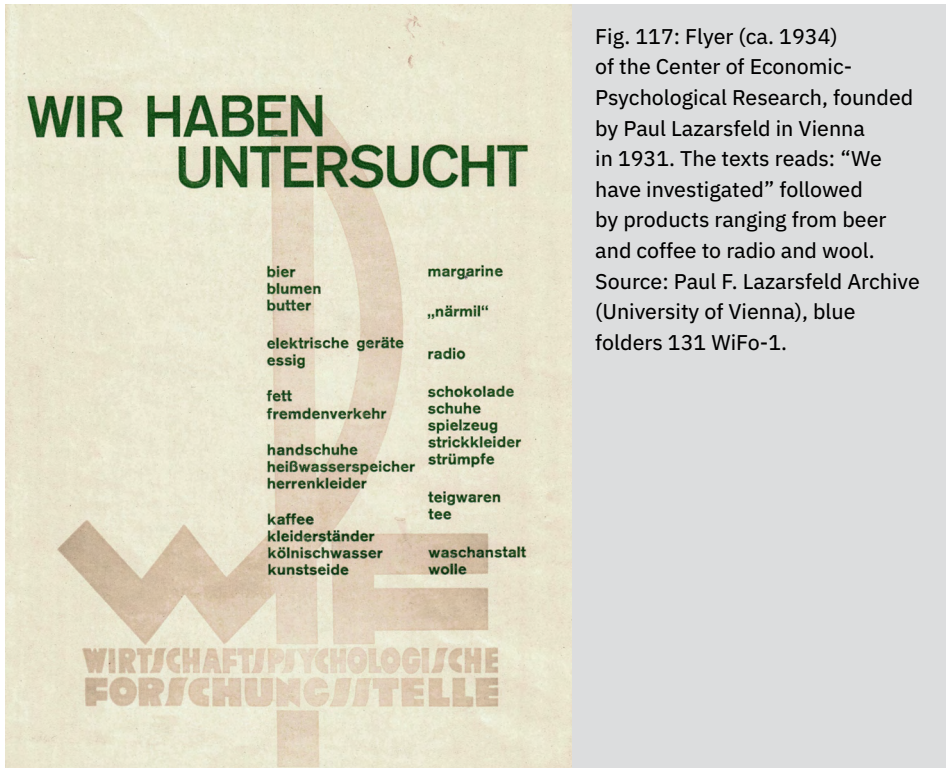

Fig. 117: Flyer (ca. 1934) of the Center of Economic-Psychological Research, founded by Paul Lazarsfeld in Vienna in 1931. The text reads: “We have investigated” followed by products ranging from beer and coffee to radio and wool. Source: Paul F. Lazarsfeld Archive (University of Vienna), blue folders 131 WiFo-1.

were three research teams: experimental psychology run by Egon Brunswik; child and adolescent psychology by Bühler’s wife Charlotte, who was appointed associate professor in 1929; and economic psychology, which was also responsible for the RAVAG studies.⁵²² After a start-up period, the latter group was officially founded by Paul Lazarsfeld as the **Center of Economic-Psychological Research** (*Wirtschaftspsychologische Forschungsstelle*) in 1931. Lazarsfeld had a doctorate in mathematics and applied his statistical skills in the late 1920s as an assistant of Charlotte Bühler (though he was not paid from university funds).⁵²³ He was born in Vienna in 1901 and grew up in a Jewish, liberal, Social Democratic household. His father

Fig. 117, p. 268

- 522 See Mitchell G. Ash: “Die Entwicklung des Wiener Psychologischen Instituts 1922–1938,” in: Achim Eschbach (ed.): *Karl Bühler’s Theory of Language*, Amsterdam: Benjamins 1988, pp. 303–325.
- 523 See Christian Fleck: *Rund um “Morienthal.” Von den Anfängen der Soziologie in Österreich bis zu ihrer Vertreibung*, Vienna: Verlag für Gesellschaftskritik 1990, pp. 150 and 160.

Robert was a lawyer, his mother Sofie a well-known individual psychologist who regularly hosted salons with leading Social Democrats like Friedrich Adler, Otto Bauer, and Rudolf Hilferding. Paul Lazarsfeld became involved in the socialist youth movement as a school student, which is also where he met his first wife, the future social psychologist Marie Jahoda.⁵²⁴

Although the Center of Economic-Psychological Research originated in the Viennese Department of Psychology, it was organized as a non-university association under the presidency of Karl Bühler.⁵²⁵ The group of young economic psychologists wanted to conduct market research in Austria in the American style and in the process create paid work for themselves. After all, the prospects of finding employment at the right-wing conservative oriented University of Vienna were slim for liberal-minded, methodically innovative social scientists and humanities scholars, and for Jews it was almost impossible. The research center carried out numerous analyses of sales transactions and product decisions, as well as of movie theater visits and leisure activities in general. However, its most famous study, initiated by Otto Bauer, the leading theorist of Austrian Social Democracy, addressed a sociopolitical problem: the severe unemployment in Marienthal in Lower Austria, which was analyzed in 1931/32 using a variety of qualitative and quantitative methods and according to the study's own results brought the village to not only an economic but also a psychological standstill.⁵²⁶

Published in 1933 and largely compiled by Marie Jahoda, the study report *Die Arbeitslosen von Marienthal* contains an appendix on the "history of sociography," which was written by Hans Zeisel, a lifelong friend of Lazarsfeld who had a doctorate in

- 524 See Marie Jahoda: "Paul Felix Lazarsfeld in Vienna," in: Jacques Lautman and Bernard-Pierre Lécuyer (eds.): *Paul Lazarsfeld (1901–1976). La sociologie de Vienne à New York*, Paris: L'Harmattan 1998, pp. 135–140. A profound analysis of Paul Lazarsfeld's intellectual socialization in Vienna can be found in the first part of the doctoral thesis by Eric Tapken Hounshell: *A Feel for the Data. Paul F. Lazarsfeld and the Columbia University Bureau of Applied Social Research*, University of California, Los Angeles: PhD diss. 2017, pp. 31–371.
- 525 See Fleck: *Rund um "Marienthal"*, pp. 159–171.
- 526 See Hynek Jeřábek: *Paul Lazarsfeld's Research Methodology. Biography, Methods, Famous Projects*, Prague: Karolinum Press 2006, pp. 70–85.

law.⁵²⁷ This essay traces the development of scientific methods for collecting data about populations, going back to the early modern period. Zeisel explains the emergence of “political arithmetic” in seventeenth-century England with the demise of the medieval social order and the growing possibilities for people and things to move more freely across territories. In an essay on the same topic published some three decades later, Lazarsfeld contrasts the British studies by John Graunt and William Petty, which he also associates with the emerging insurance industry, with the German statistics in terms of a comparative theory of the state, which was greatly influenced by Gottfried Achenwall in Göttingen in the eighteenth century.⁵²⁸

For the nineteenth century the historical perspectives of the texts by Zeisel and Lazarsfeld correspond, according to which the crucial progress in empirical social research resulted from Adolphe Quetelet and Frédéric Le Play. While the Belgian Quetelet attempted with his “social physics” and “moral statistics” to identify patterns in human behavior and define an “average man” on the basis of probability calculations, the French Le Play developed new methods to compile social data with his “family monographs.” Furthermore, Zeisel cites the lifestyle analyses of Max Weber and the *Middletown* study by Robert and Helen Lynd published in 1929 as being sociographically exemplary. Contemporary American social and market research with its clipping bureaus to collect newspaper cutouts and its standardized questionnaires, however, threatened to deteriorate into “survey machinery” amassing endless data. According to Zeisel, the Vienna Center of Economic-Psychological Research avoided this wrong track by systematically interleaving statistical analyses with concept formation.⁵²⁹

In point of fact, neither the study on unemployment in Marienthal nor the comprehensive listener survey for the

527 See Österreichische Wirtschaftspsychologische Forschungsstelle (ed.): *Die Arbeitslosen von Marienthal. Ein soziographischer Versuch über die Wirkungen langandauernder Arbeitslosigkeit mit einem Anhang zur Geschichte der Soziographie*, Leipzig: Hirzel 1933, pp. 89–123.

528 See Paul F. Lazarsfeld: “Notes on the History of Quantification in Sociology. Trends, Sources and Problems,” in: *Isis*, 52/2 (1961), pp. 277–333.

529 See Wirtschaftspsychologische Forschungsstelle (ed.): *Die Arbeitslosen von Marienthal*, pp. 106–123 [our trans.].

RAVAG can be accused of mere “nose-counting.”⁵³⁰ Whereas the social-psychological research project stands out for its original combination of methods, the survey on Austrian radio is striking for its then novel correlation between the collated data. After all, the form distributed in the radio magazines and tobacco shops entitled “What do you want to hear?” contained not only questions on fifty-four program categories, which were to be answered with “more (+), less (–), or the same amount (=),” but also on the listeners’ place of residence, age, gender, and occupation.⁵³¹ How welcome this survey was is expressed by the remarkable response rate: although there was not much time to answer the questions and postage had to be paid by the respondents themselves, the RAVAG received some 36,000 completed questionnaires, which had been filled out by slightly over three people on average. That means that almost every tenth of the 400,000 Austrian households who had a registered radio in late 1931 had taken part in the survey.⁵³² Statistically structuring the audience according to profession was already commonplace in Germany around 1930.⁵³³ However, the RAVAG study’s final report written in 1932 divided the 110,312 listeners who had recorded their wishes on the questionnaires not only into different social classes, but also correlated these listener types with program categories.⁵³⁴ In other words, the statistical

- 530 Paul F. Lazarsfeld: “An Episode in the History of Social Research. A Memoir” [1968], in: Patricia L. Kendall (ed.): *The Varied Sociology of Paul F. Lazarsfeld*, New York: Columbia University Press 1982, pp. 11–69, here p. 33: “At the time, American market research was based mainly on rather simple nose-counting.”
- 531 See the facsimile of the questionnaire in Desmond Mark (ed.): *Paul Lazarsfelds Wiener RAVAG-Studie 1932. Der Beginn der modernen Rundfunkforschung*, Vienna: Guthmann-Peterson 1996, pp. 67–70.
- 532 See Gertrud Wagner: “Die Programmwünsche der österreichischen Radiohörer,” in: *Archiv für die gesamte Psychologie*, 90 (1934), pp. 157–164, here p. 157.
- 533 See Franz Frühwald: “Rundfunkzahlen und ihre Wertung,” in: *Radio-Amateur* (Vienna), 9/2 (February 1932), pp. 73–78; Jacob Blauner: “Wer hört alles Rundfunk? Berufsstatistik der deutschen Hörschaft,” in: *Radiowelt* (Vienna), 8/46 (November 14, 1931), pp. 1477–1478.
- 534 See [Paul F. Lazarsfeld:] “Hörerbefragung der Ravag” (52-page typescript), Paul Felix Lazarsfeld Papers (Butler Library, Columbia University, New York), box 35, folder 26, published in Mark (ed.): *Paul Lazarsfelds Wiener RAVAG-Studie 1932*, pp. 27–66.

analysis by the Center of Economic-Psychological Research created specific target groups.

The hundreds of thousands of opinions expressed in the questionnaires had to be entered into tables by hand and analyzed using thousands of calculations. In order to portray the results intelligibly, the negative (–) votes were subtracted from the positive (+) ones. As the neutral (=) entries always accounted for roughly a third of the total, this “popularity coefficient”⁵³⁵ produced a clear picture of listener requests. For example, the calculated figure for topical scientific lectures among men living in Vienna amounted to +17, but among women from the provinces –11. Whereas the workers wanted to hear jazz more often on the radio (+28), this controversial genre was rejected in intellectual circles (–19). The statistical analyses also showed that workers’ spiritual interests increased with age, while the opposite trend was true for the bourgeoisie. Overall, the most popular programs included variety shows (+67) and comedies (+45), with chamber music (–66) and literary readings (–47), for example, being strongly disliked. Less popular were also ideological lectures (–14) and topical running commentaries (–14), which could be considered to include the transmission of the “Turks Deliverance Celebration.” In the appendix to the study report, the content of the numerous letters enclosed with the questionnaires was summarized and excerpts were quoted. One frequently expressed request was evidently to broadcast the entertainment programs before 10 p.m. in the evening and on the weekend, with a tailor from the Mühlviertel in Upper Austria even sending in a complete week’s program—adapted to his daily routine—to illustrate this wish.⁵³⁶

The complete study report on the listener survey was only published in 1996, after the fifty-two-page typescript had been discovered in Lazarsfeld’s papers.⁵³⁷ Nevertheless, a four-page article summarizing the results appeared in the magazine *Radio Wien* in early November 1932. The unnamed author assured readers toward the end of the text that the survey would have

Fig. 118, p. 273

535 Wagner: “Die Programmwünsche der österreichischen Radiohörer,” p. 158 [our trans.].

536 See [Lazarsfeld:] “Hörerbefragung der Ravag.”

537 See Mark (ed.): *Paul Lazarsfelds Wiener RAVAG-Studie 1932*.



Fig. 118: On November 4, 1932, the magazine *Radio Wien* reported on the results of the audience survey conducted by the Center of Economic-Psychological Research for the Austrian Radio Verkehrs AG. Source: Austrian National Library, 607949-C.

an impact on programming. For example, *Radio Wien* would be broadcasting more entertainment shows in the early evening, as desired by the majority of listeners. “Yet it must not be forgotten,” the article continues, “that alongside entertainment and distraction, radio must also offer instruction and improvement in order to merit its cultural significance.” Radio was capable of “increasingly raising the level of education of the broadest swathes” and it was down to the public not to listen “indiscriminately,” but to follow certain programs with the necessary “concentration.”⁵³⁸ Such admonitions were entirely in accordance with the RAVAG’s self-understanding as a public service broadcaster, which conceived of its program in terms of a wireless adult education center. From 1933, however, this mission to educate the people was put to the service of propaganda by dictatorial regimes in Austria and Germany alike.

538 “Die Hörerbefragung der Ravag,” in: *Radio Wien* (Vienna), 9/6 (November 4, 1932), pp. 2–5, here p. 5 [our trans.].

III.3.4

That the RAVAG study from 1931/32 nevertheless had an impact is related to Paul Lazarsfeld's career path. In his memoirs he emphasized that his interest in social classes had conceptual roots.⁵³⁹ In line with **Austro-Marxism**, the Austrian school of Marxist thought, the young social psychologist interpreted consumer and leisure behavior as part of political life: what, for example, characterized the proletarian lifestyle in Vienna around 1930? Moreover, he attempted to analyze decision-making processes to influence elections in favor of the Social Democratic Workers' Party. "Such is the origin of my Vienna market research studies," wrote Lazarsfeld retrospectively, "the result of the methodological equivalence of socialist voting and the buying of soap."⁵⁴⁰ In September 1933 he traveled to New York on a grant from the Rockefeller Foundation to study the American methods of social and market research.⁵⁴¹ His original plan was to return to Austria and apply his newly gained knowledge for the Center of Economic-Psychological Research. However, due to the political upheavals in Europe and the appreciably better career prospects in the USA, Lazarsfeld decided in 1935 to remain in New York, where he went on to become one of the most influential sociologists and communication researchers of the twentieth century.⁵⁴²

In a lecture in Salzburg in 1974, the by then emeritus professor of sociology at Columbia University said that the early survey of Austrian radio listeners became the foundation of "what was for many years the main feature of American audience research."⁵⁴³ In 1937 Lazarsfeld, at the recommendation of Robert Lynd, the author of the sociological study *Middletown* (1929), was appointed the head of an extensive research project

539 See Lazarsfeld: "An Episode in the History of Social Research," pp. 17–24.

540 Lazarsfeld: "An Episode in the History of Social Research," p. 19.

541 See Christian Fleck and Nico Stehr: "Einleitung. Von Wien nach New York," in: Paul F. Lazarsfeld: *Empirische Analyse des Handelns. Ausgewählte Schriften*, trans. Hella Beister, ed. Christian Fleck and Nico Stehr, Frankfurt a.M.: Suhrkamp 2007, pp. 7–58.

542 See Thymian Bussemer: "Paul Felix Lazarsfeld und die Etablierung der Kommunikationsforschung als empirische Sozialwissenschaft," in: *Medien & Kommunikationswissenschaft*, 55/1 (2007), pp. 80–100.

543 Paul Lazarsfeld: "Zwei Wege der Kommunikationsforschung," in: Oskar Schatz (ed.): *Die elektronische Revolution. Wie gefährlich sind die Massenmedien?*, Graz: Styria 1975, pp. 197–222, here p. 204 [our trans.].

on radio use in the USA, which was officially connected with Princeton University but was initially carried out in Newark in New Jersey and from 1939 to 1944 at Columbia University in New York.⁵⁴⁴ Also involved in this project, which was largely financed by the Rockefeller Foundation, were a number of his colleagues from the Center of Economic-Psychological Research who had had to flee from Austria due to their political convictions or Jewish heritage, including Marie Jahoda, Hans Zeisel, Ernest Dichter, who would later become a famous motivation researcher, and Lazarsfeld's second wife Herta Herzog, who had completed a doctoral thesis under Karl Bühler in Vienna in 1932 on the aforementioned RAVAG experiment on voice recognition on the radio.⁵⁴⁵

At first the research group did principally the same as they had done in Austria, namely evaluating statistics on the radio audience's programming requests and social data in such a way that different types of listeners emerged. However, the main difference lay in the fact that in the USA these statistical analyses could be exploited for financial gain and were therefore in high demand. While Austria and Germany—like most European states—organized radio as public service broadcasting, the American radio stations were commercial enterprises from the outset and were not funded by licenses but by advertising. In the USA in the early 1930s, some seventeen million radio sets received the transmissions of over 600 radio stations.⁵⁴⁶ In order to use this new mass medium for targeted advertising, programs had to be sold on the stations and at the times that reached as many of the desired consumers as possible. This division of the radio audience

544 See Lazarsfeld: "An Episode in the History of Social Research," pp. 40–69.

545 See Herta Herzog: *Stimme und Persönlichkeit*, University of Vienna: PhD diss. 1932. This study, the results of which appeared in the *Zeitschrift für Psychologie* in 1933 (130/3–5, pp. 300–369), replicated an experiment from 1927 conducted by the British psychologist Tom Hatherley Pear: *Voice and Personality*, London: Chapman and Hall 1931, pp. 151–177.

546 See Hadley Cantril and Gordon W. Allport: *The Psychology of Radio*, New York/London: Harper & Brothers 1935, p. 37.

into different target groups was a financially valuable research achievement by the Office of Radio Research.⁵⁴⁷

However, the group of researchers did not limit themselves to statistical analyses but also conducted laboratory experiments.⁵⁴⁸ Back in Vienna Lazarsfeld had already had the idea to test the plus/minus evaluation of radio programs used for the RAVAG study in experiments. In collaboration with Frank Stanton, who ran the research department of Columbia Broadcasting System (CBS) and was the codirector of the Office of Radio Research, Lazarsfeld now developed this concept into the so-called “**program analyzer**” in 1937/38, which was used primarily in the 1940s. It was a polygraph to synchronously measure the program reactions of selected listeners. The test subjects sat together in a radio studio and listened to a certain radio program, which they could rate with a green (+) or a red (–) button. These reactions were recorded on a roll of paper as deviations upward (+) or downward (–). If the participants did not press either button, the line remained in the middle, which expressed a neutral attitude. On the basis of this timescale, it was possible to establish precisely which parts of the program met with approval and which were disliked.

As it was too expensive for the Office of Radio Research to repeat the experiment several times, Lazarsfeld and Stanton sold the use rights to CBS and the New York advertising agency McCann-Erickson, where Herta Herzog and Hans Zeisel worked as head market researchers from 1943.⁵⁴⁹ Another qualitative method was developed in connection with the program analyzer that is still used in empirical market and social research today. To interpret the results, the experiment was followed by lengthy group interviews in which the test subjects were asked to explain their spontaneous reactions to the program. Lazarsfeld’s colleague from Columbia University, the sociologist Robert K. Merton, made the technique famous as the “focused

Fig. 119, p. 277

547 See Paul Neurath: “Die methodische Bedeutung der RAVAG-Studie von Paul F. Lazarsfeld,” in: Desmond Mark (ed.): *Paul Lazarsfelds Wiener RAVAG-Studie 1932. Der Beginn der modernen Rundfunkforschung*, Vienna: Guthmann-Peterson 1996, pp. 11–26.

548 On the following, see Jeřábek: *Paul Lazarsfeld’s Research Methodology*, pp. 32–36.

549 See Lazarsfeld: “An Episode in the History of Social Research,” pp. 62–63.

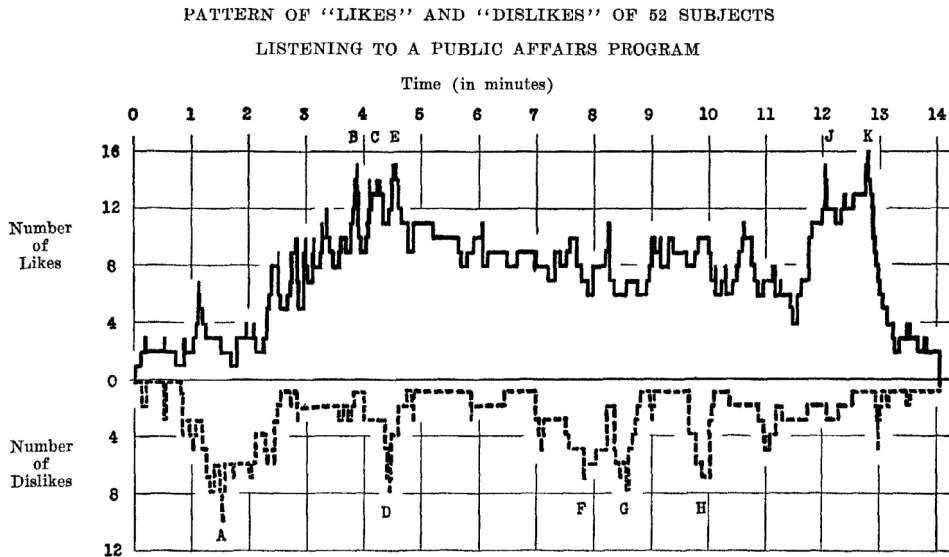

Fig. 119: Graph of fifty-two subjects rating a radio broadcast with Paul Lazarsfeld and Frank Stanton's "program analyzer," represented in Jack N. Peterman: "The 'Program Analyzer.' A New Technique in Studying Liked and Disliked Items in Radio Programs," in: *The Journal of Applied Psychology*, 24/6 (1940), pp. 728–741, here p. 733. Source: Vienna University Library, NEURATH-5387.

interview" and later as the "focus group."⁵⁵⁰ However, it has since been proven that this method was actually developed by Herta Herzog, who alongside Ernest Dichter became the most important advocate of the "Vienna school of motivation research" in American marketing.⁵⁵¹

550 See Robert K. Merton: "The Focused Interview and Focus Groups. Continuities and Discontinuities," in: *Public Opinion Quarterly*, 51/4 (1987), pp. 550–566.

551 It was Hans Zeisel who first spoke of a "Vienna school of motivation research" (*Wiener Schule der Motivforschung*) in an opening address at a conference for market and opinion research in Vienna in 1967. The text was published in Josef Langer (ed.): *Geschichte der österreichischen Soziologie. Konstituierung, Entwicklung und europäische Bezüge*, Vienna: Verlag für Gesellschaftskritik 1988, pp. 157–166. On Herta Herzog and Ernest Dichter, see Elisabeth Klaus and Josef Seethaler (eds.): *What Do We Really Know About Herta Herzog? Exploring the Life and Work of a Pioneer of Communication Research*, Frankfurt a.M.: Peter Lang 2016, and Stefan Schwarzkopf and Rainer Gries (eds.): *Ernest Dichter and Motivation Research. New Perspectives on the Making of Post-War Consumer Culture*, New York: Palgrave Macmillan 2010.

3.3 Marketing: “Torches of Freedom”



place	<i>Neue Freie Presse</i> editorial offices
moment	Publication of “Humbug, Bluff, and Ballyhoo”
space	424 m away
time	191 d 0 h 0 min later

II.10 Is it a coincidence that the Vienna *Neue Freie Presse* published an essay on new American propaganda methods on May 14, 1933, the day of the “**Turks Deliverance Celebration**” (*Türkenbefreiungsfeier*)? While the Austrian Homeland Protection (*Heimatschutz*) was holding a rally in the **Schönbrunn Palace gardens**, on which numerous newspapers, *Fox Movietone News*, and III.1.3 *Radio Wien* reported, the bourgeois paper’s Sunday edition III.2.2 featured a long article about the “analyst of the mass psyche Edward L. Bernays,” who had developed “indirect advertising” in the style of the circus pioneer and businessman **P.T. III.3.1 Barnum** into a scientific service. The New York-based counsel on public relations, as Bernays himself termed his profession, may have seemed particularly interesting to the *Neue Freie Presse* because he was related to Sigmund Freud. “The uncle in Vienna reveals the subconscious in the individual’s instinctual life; the American nephew analyzes the unsatisfied desires of the masses,” the article’s author Arthur Rundt says of the familial and intellectual connection between the founder of psychoanalysis and this “expert in public opinion.”⁵⁵²

Fig. 27, p. 75

Presumably, it was a coincidence that the publication of the article entitled “Humbug, Bluff, and Ballyhoo” coincided with the “Turks Deliverance Celebration.” Although the *Neue Freie Presse* took a rather critical stance on the rally of the Home Guards (*Heimwehren*) in Schönbrunn in the leading article,⁵⁵³

552 Arthur Rundt: “Humbug, Bluff und Ballyhoo. Von Barnum bis Bernays,” in: *Neue Freie Presse* (Vienna), May 14, 1933 (morning edition), pp. 25–26 [our trans.].

553 See “Die Befreiung Wiens und die Gegenwart,” in: *Neue Freie Presse* (Vienna), May 14, 1933 (morning edition), pp. 1–2.

- it is unlikely that an association with the advertising techniques of Edward Bernays was intended. It is equally unlikely that
- III.1.1 **Ernst Rüdiger Starhemberg**, the federal leader of the Austrian Homeland Protection and the initiator of the event, was familiar with the books and campaigns by the American PR counsel. Nevertheless, parallels can be observed. After all, Starhemberg had the anniversary of Vienna's liberation from the Ottoman siege in summer 1683 marked on May 14, 1933, even though a state "Turks Deliverance Celebration" had already been planned for the actual 250th anniversary of the relief on September 12, 1933.⁵⁵⁴ It was a gratuitous event that was intended to cause a public sensation and hence propagate the political idea of
- III.2.1 **Austrofascism**. This idea was communicated through a series of historical stereotypes: of the city of Vienna as a Christian stronghold, of Austrian Germanness, of the threat of barbarism from the East, of aristocratic war heroes.

Both strategies—the creation of pseudo-events and the targeted use of stereotypes—were part of Edward Bernays's PR arsenal. His family had emigrated from Vienna to the USA in 1892, the year after his birth. The agriculture graduate and former journalist had studied works on mass and social psychology by Gustave Le Bon and Wilfred Trotter, and later by Walter Lippmann, whose theories he translated into specific campaigns in his New York public relations agency from 1919.⁵⁵⁵ In his books *Public Opinion* (1922) and *The Phantom Public* (1925), Lippmann described among other things the criteria according to which journalists selected news stories and how public opinion could be influenced by emotional symbols.⁵⁵⁶ Bernays offered to the political and economic elites that, in exchange for a fee, he could apply this knowledge in order to steer the masses, who elected parties and chose products, in certain directions. To advertise his services in

- 554 See Silvia Dallinger: "Katholikentag & Staatliche Türkenbefreiungsfeier 1933," in: Johannes Feichtinger and Johann Heiss (eds.): *Türkengedächtnis* (2010), URL: www.oeaw.ac.at/tuerkengedaechtnis/home/feiern/250-jaehriges-jubilaum-1933/katholikentag-staatliche-tuerkenbefreiungsfeier.
- 555 See Stuart Ewen: *PR! A Social History of Spin*, New York: Basic Books 1996, pp. 146–173.
- 556 See Walter Lippmann: *Public Opinion*, New York: Harcourt, Brace and Co. 1922; *The Phantom Public*, New York: Harcourt, Brace and Co. 1925.



Fig. 120: Screenshot of the Topology module of the website campusmedius.net (mobile version 2.0/2021) showing the mediator "Torches of Freedom" in the mediation "How to Speak Up: Governed Transmissions" (text: Simon Ganahl, code: Andreas Krimbacher, design: Susanne Kiesenhofer).

the 1920s, he published not only numerous articles, but also the books *Crystallizing Public Opinion* (1923) and *Propaganda* (1928), which reported on social-psychological findings and demonstrated using practical examples how they could be applied in everyday PR.

A campaign that is named by way of example in both books, as well as in the essay in the *Neue Freie Presse*, aimed to sell bacon by the Beech-Nut Packing Company.⁵⁵⁷ The company from the state of New York commissioned Bernays in the early 1920s with increasing demand for its sliced bacon. Instead of running advertisements that promoted the product as particularly good value or tasty, he asked a doctor friend of his if he could send letters in his name to physicians throughout North America. In the letter he asked whether it was healthier to eat a hearty meal of bacon, eggs, oats, and fruit in the morning or to start the day with coffee and toast. Bernays had the outcome, according to which three quarters apparently advocated a substantial breakfast, printed in a medical journal for which he had worked as a journalist:

*As the result of a nation-wide survey among the leading physicians of forty-six states, the Medical Review of Reviews has established the dictum that for brain workers the substantial breakfast, followed by a light luncheon, is the preferable regimen for health.*⁵⁵⁸

Already communicated beforehand through press releases, this “finding” was reported by several newspapers, including the *New York Times* and the *New York Post*, who proclaimed a comeback for old eating habits. It had looked as though the small European, so-called continental breakfast would also become established in the USA, commented the *Post*. Now, however, a return to the “traditional American breakfast” could be recommended.⁵⁵⁹

557 See Edward L. Bernays: *Crystallizing Public Opinion*, New York: Horace Liveright 1923, pp. 18–19; Edward L. Bernays: *Propaganda*, New York: Horace Liveright 1928, pp. 53–54; Rundt: “Humbug, Bluff und Ballyhoo,” p. 25.

558 Frederic H. Robinson: “The Hearty Breakfast Wins,” in: *Medical Review of Reviews*, 28/11 (November 1922), pp. 503–508, here p. 503 [emphasis in original].

559 Cit. after Robinson: “The Hearty Breakfast Wins,” p. 507.



Fig. 121: Advertisement for the Beech-Nut Packing Company from around 1930, contained in the archives of the Beech-Nut Packing Company. Source: Arkell Museum (Canajoharie, NY).

Bernays's campaign for the Beech-Nut Packing Company is instructive because it illustrates the basic principle of his public relations at the time. "Ballyhoo teaches that the masses are most surely steered when 'group leaders' are won over for the cause whom the lower-ranking group will gladly follow," reported Rundt in the *Neue Freie Presse*.⁵⁶⁰ Bernays emphasized this technique on several occasions in his book *Propaganda*: those who want to steer public opinion in a specific direction should influence the relevant target groups via their opinion leaders.⁵⁶¹ In the case of the bacon campaign, office workers' eating habits should be changed through the expert advice of medics. That means that it was not about advertising a particular article over the competition. Rather, Bernays aimed to create lifestyles that associated behaviors with commodities.⁵⁶² The "perfect breakfast" in this sense was truly American, comprising produce from Beech-Nut in Canajoharie, New York, as an **advertisement**—created around 1930—from the company archive illustrates: the caring wife serves her husband a hearty meal of eggs and bacon in the

Fig. 121, p. 282

560 Rundt: "Humbug, Bluff und Ballyhoo," p. 26 [our trans.].

561 See Bernays: *Propaganda*, pp. 28, 37, 40–41, 47–50, 53–54, 59, 92, 102.

562 On the history of public relations as a social apparatus for governing conducts, see Cory Wimberly: *How Propaganda Became Public Relations. Foucault and the Corporate Government of the Public*, New York: Routledge 2020.

morning, which not only tastes good, but is also medically recommended for modern daily life in the office.

Another example of this lifestyle marketing is the campaign for the American Tobacco Company that has come to be known as “torches of freedom.” From 1928 Bernays was hired by George Washington Hill, the president of the company who wanted to encourage more women to smoke Lucky Strike.⁵⁶³ The PR counsel did not follow the cigarette brand’s traditional advertising slogan, “It’s toasted,” which was intended to emphasize that “Luckies” tasted especially good and went easy on the throat due to their unique manufacturing process, but rather attempted to position cigarettes as a fashionable accessory. He had special cigarette holders sent to models and photographers, a tactic that was entirely consistent with the new advertising slogan: “Reach for a Lucky instead of a sweet!”⁵⁶⁴ Smoking reduced feelings of hunger, went the argument, and helped women to look slim and gamine, as was now fashionable.

As part of this campaign, Bernays staged a protest at the Easter parade in New York City on March 31, 1929. He convinced or paid roughly a dozen young women, who were supposed to look attractive but not like models and included his secretary Bertha Hunt, an employee of the fashion magazine *Vogue* called Nancy Hardin, and the women’s rights campaigner Ruth Hale, to smoke in public on Fifth Avenue on Easter Sunday and tell passersby that they were lighting up “torches of freedom.” After all, they claimed, it was a ridiculous taboo that it was considered indecent for women to smoke in public but not for men.⁵⁶⁵ In their reports on the traditional parade, the *New York Times* and many other newspapers mentioned the pointedly smoking women, who had walked back and forth between St. Patrick’s Cathedral and St. Thomas Church after the Easter Mass.⁵⁶⁶ Photographers, whom Bernays had

563 See Larry Tye: *The Father of Spin. Edward L. Bernays & The Birth of Public Relations*, New York: Crown 1998, pp. 23–50.

564 See Edward L. Bernays Papers, Library of Congress (Washington, D.C.), box I:84.

565 The campaign is well documented in the Edward L. Bernays Papers, boxes I:84–88.

566 See, for example, “Easter Sun Finds the Past in Shadow at Modern Parade,” in: *The New York Times* (New York City), April 1, 1929, pp. 1 and 3.

Fig. 122, p. 284

sent to the right place at the right time, provided the press with **pictures of the good-looking, well-dressed women** and their “torches of freedom” that were printed throughout the country.⁵⁶⁷

The staged protest demonstrates very clearly how Bernays created and dramatized events to attract public attention.⁵⁶⁸ While it is disputable just how much of an influence the campaign actually had on women’s smoking behavior,⁵⁶⁹ the dozens of newspaper articles in which the event was described or illustrated cannot be argued away. However, the press not only reproduced Bernays’s story of the feminists smoking as a symbol of liberty but also pointed out that the parade participants had hardly concerned themselves with

them because women smoking in public had long been commonplace.⁵⁷⁰ This means that it was in fact a pseudo-event, which only took place for the media and in the media, with the aim of associating smoking with emancipation in the public consciousness. According to this PR concept, a woman fighting



Fig. 122: Edith Lee walking on Fifth Avenue in New York at around noon on March 31, 1929, as one of the young women whom Edward Bernays hired on behalf of the American Tobacco Company to smoke in public at the Easter parade. Source: Library of Congress (Washington, DC), Prints & Photographs LOT 15019 no. 13.

567 See the corresponding collection of newspaper clippings in the Edward L. Bernays Papers, boxes I:519–522.

568 On pseudo-events and dramatization as PR techniques, see Bernays: *Propaganda*, pp. 25, 69–70, 93, 151–152.

569 See Tye: *The Father of Spin*, pp. 31–35.

570 See Vanessa Murphree: “Edward Bernays’s 1929 ‘Torches of Freedom’ March. Myths and Historical Significance,” in: *American Journalism*, 32/3 (2015), pp. 258–281, here pp. 273–275.



Fig. 123: Eugène Delacroix: *La Liberté guidant le peuple* (1830). Source: Musée du Louvre (Paris), Département des Peintures RF 129.



Fig. 124: The Statue of Liberty in New York's harbor, photographed around 1930. Source: National Archives and Records Administration (Washington, DC), 594414.

Fig. 123, p. 285

Fig. 122, p. 284

Fig. 124, p. 285

for her freedom no longer had to climb the barricades as Eugène Delacroix had depicted in his famous painting *La Liberté guidant le peuple* from 1830, but merely **walk confidently down Fifth Avenue**—in high heels and a matching hat, with a leather bag under her arm and a “Lucky” in her hand. The cigarette was supposed to be reminiscent of the torch of the **Statue of Liberty**, erected in New York's harbor in 1886, which embodies the Roman goddess of liberty, though without the revolutionary gesture of the *Libertas* by Delacroix.

According to his autobiography, the idea of marketing cigarettes as “torches of freedom” came to Bernays after a conversation with Abraham Brill, a psychoanalyst who had emigrated from Austria and was now practicing in New York.⁵⁷¹ That modern propaganda had to understand and influence the subconscious motives of human actions, for example by portraying smoking as an emancipatory act, was highlighted multiple times by Bernays in his writings around 1930.⁵⁷² He

571 See Edward L. Bernays: *Biography of an Idea. Memoirs of Public Relations Counsel Edward L. Bernays*, New York: Simon and Schuster 1965, p. 386.

572 See Bernays: *Propaganda*, p. 52; Edward L. Bernays: “Manipulating Public Opinion. The Why and the How,” in: *American Journal of Sociology*, 33/6 →

referenced the findings of depth psychology and never tired of mentioning his relative Sigmund Freud. Although Bernays emphasized that public relations had its origin in science, in truth his campaigns were based on intuition and personal relationships. Furthermore, his correspondence with Freud makes clear that his Viennese uncle thought little of his New York nephew's profession. When Bernays sent him the book *Crystallizing Public Opinion*, Freud responded disparagingly that it had interested him as being "truly American."⁵⁷³

While Bernays claimed for purposes of self-promotion that he was applying psychological methods in public relations, in Vienna there was a group of young scientists who really were conducting motivation research in this sense. This group of researchers emerged at the Department of Psychology at the University of Vienna, which was run by Karl and Charlotte Bühler, and operated as a non-university association under the name **Center of Economic-Psychological Research** (*Wirtschaftspsychologische Forschungsstelle*) from 1931.⁵⁷⁴ Although the plan to earn money with market research largely failed in Vienna, these sociologists and psychologists were laying the methodical foundations for their future success in the USA. The research center was founded and run by Paul Lazarsfeld, who had a doctorate in mathematics and who traveled to New York on a grant from the Rockefeller Foundation in 1933.⁵⁷⁵ There he wanted on the one hand to get to know new methods of social and market research and on the other to make known the techniques already developed by the Center of Economic-Psychological Research in Vienna. He summarized these findings in two papers, which

III.3.2 &
Fig. 117, p. 268

- (1928), pp. 958–971; Edward L. Bernays: "Mass Psychology and the Consumer" (speech given in Boston on September 22, 1930), Edward L. Bernays Papers, Library of Congress (Washington, D.C.), box I:422.
- 573 Letter by Sigmund Freud to Edward Bernays, dated May 11, 1924, Edward L. Bernays Papers, Library of Congress (Washington, D.C.), box III:1 [our trans.].
- 574 See Christian Fleck: *Rund um "Morienthal." Von den Anfängen der Soziologie in Österreich bis zu ihrer Vertreibung*, Vienna: Verlag für Gesellschaftskritik 1990, pp. 159–171.
- 575 See Christian Fleck and Nico Stehr: "Einleitung. Von Wien nach New York," in: Paul F. Lazarsfeld: *Empirische Analyse des Handelns. Ausgewählte Schriften*, trans. Hella Beister, ed. Christian Fleck and Nico Stehr, Frankfurt a.M.: Suhrkamp 2007, pp. 7–58.

were published in the mid-1930s and went on to form the foundation of motivation research in American marketing.⁵⁷⁶

Lazarsfeld's article "The Art of Asking Why," which was published in an American Marketing Association journal in 1935, explores the formulation of questionnaires in market research.⁵⁷⁷ To find out why a certain product was being purchased, it was necessary to question selected consumers at length and in depth. This kind of survey could not be conducted using standardized forms but only with the aid of psychologically trained interviewers whose skillful and patient conversation techniques were capable of discovering the true motives of purchasing actions. The concept of "motive" is also at the heart of the article "The Psychological Aspect of Market Research," which Lazarsfeld published in the *Harvard Business Review* in 1934. Motives should not be confused with the queried reasons for buying an item but were to be understood as "concepts of connection" in the statistical analysis of the collected data.⁵⁷⁸ According to Lazarsfeld, the **act of purchasing** comprised a complex interplay of internal impulses (e.g., hunger), external influences (e.g., advertising), and attributes of the commodity (e.g., packaging). Applied economic psychology analyzed this relational setting, which differed from case to case, and advised companies how to find the appropriate advertising means for each product.

In both articles, Lazarsfeld criticized the then common practice in American market research of compiling masses of superficial data and basing their analysis on universal motives. Instead, he advocated the use of qualitative interviews and the development of consumer typologies. Hierarchies of needs were useless in this regard, says a typescript by the Center of

Fig. 125, p. 288

- 576 See Ron Fullerton: "The Beginnings of Motivation Research, 1934–1954. A Prequel to Fullerton 2013," in: *Journal of Historical Research in Marketing*, 7/4 (2015), pp. 509–523; Lawrence R. Samuel: *Freud on Madison Avenue. Motivation Research and Subliminal Advertising in America*, Philadelphia/Oxford: University of Pennsylvania Press 2010, pp. 21–53.
- 577 See Paul F. Lazarsfeld: "The Art of Asking Why in Marketing Research. Three Principles Underlying the Formulation of Questionnaires," in: *National Marketing Review*, 1/1 (1935), pp. 26–38.
- 578 Paul F. Lazarsfeld: "The Psychological Aspect of Market Research," in: *Harvard Business Review*, 13/1 (1934), pp. 54–71, here p. 70.

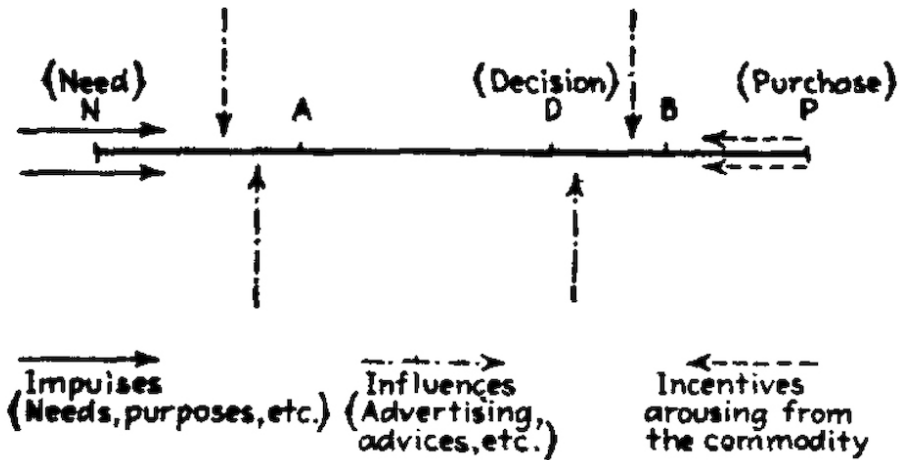

Fig. 125: Diagram on the structure of purchase actions, represented in Paul F. Lazarsfeld: “The Psychological Aspect of Market Research,” in: *Harvard Business Review*, 13/1 (1934), pp. 54–71, here p. 65. Source: Bielefeld University Library, 990/0096739+01.

Economic-Psychological Research, because people’s desires depended on social and cultural circumstances.⁵⁷⁹ After all, the text argues, a glass of water had a different value in the desert than in the city. To be able to generalize despite this, “worlds of needs” had to be formed: “According to the principle of environmental research, one constructs a world comprising a group of people and a real or spiritual object and attempts to identify the fundamental relationships (and potentially those most responsive to intervention): the vinegar market, the world of the boy, etc.”⁵⁸⁰ What Lazarsfeld describes in these typescripts written in Vienna around 1930 corresponds to the lifestyle marketing known as public relations that had been practiced by Edward Bernays in New York since the 1920s.

In contrast to the intuitive approach of the PR counsel, Lazarsfeld and his colleagues created scientific methods to define and be able to influence psychological motives and social target groups. This development started in the Center of

579 See [Paul F. Lazarsfeld:] “Der Gegenstand der Wirtschaftspsychologie” (24-page typescript, here pp. 13–14), Paul Felix Lazarsfeld Papers (Butler Library, Columbia University, New York), box 35, folder 27.

580 [Paul F. Lazarsfeld: “Bedürfnis”] (20-page typescript, here pp. 12–13), Paul Felix Lazarsfeld Papers, box 33, folder 1 [our trans.].

III.3.2 Economic-Psychological Research and went via the **Princeton Radio Project** to the Bureau of Applied Social Research at Columbia University, where not only was target group and motivation research conducted, but the concept of opinion leaders applied by Bernays was also empirically proven.⁵⁸¹ In a study led by Lazarsfeld on the American presidential campaign of 1940, the results of which were published four years later under the title *The People's Choice*, it was verified by using the panel method, i.e., the repeated questioning of selected individuals, that the impact of media coverage on the population's voting behavior was not direct, but took place via "opinion leaders."⁵⁸² This model of a two-step flow of communication seriously called into question the notion of omnipotent mass media and conversely emphasized the importance of personal relationships and the activity of the audience.⁵⁸³

Lazarsfeld subsequently concentrated more on the quantitative methods of sociology, but the qualitative tradition of Viennese communication and motivation research was continued by some of his colleagues, above all Herta Herzog and Ernest Dichter, who had previously been active at the Center of Economic-Psychological Research. From 1943 Herzog worked as a market researcher for the New York advertising agency McCann-Erickson, where she applied in-depth interviews, focus groups, and projective methods like the Rorschach test to create commercial product images.⁵⁸⁴ Dichter opened his

- 581 See Paul F. Lazarsfeld: "An Episode in the History of Social Research. A Memoir" [1968], in: Patricia L. Kendall (ed.): *The Varied Sociology of Paul F. Lazarsfeld*, New York: Columbia University Press 1982, pp. 11–69. On the Columbia Bureau of Applied Social Research, see Eric Tapken Hounshell: *A Feel for the Data. Paul F. Lazarsfeld and the Columbia University Bureau of Applied Social Research*, University of California, Los Angeles: PhD diss. 2017, pp. 437–590.
- 582 See Paul F. Lazarsfeld, Bernard Berelson, Hazel Gaudet: *The People's Choice. How the Voter Makes Up His Mind in a Presidential Campaign*, New York: Duell, Sloan and Pearce 1944.
- 583 See Thymian Bussemer: "Paul Felix Lazarsfeld und die Etablierung der Kommunikationsforschung als empirische Sozialwissenschaft," in: *Medien & Kommunikationswissenschaft*, 55/1 (2007), pp. 80–100, here pp. 92–94.
- 584 See Elisabeth Klaus and Josef Seethaler (eds.): *What Do We Really Know About Herta Herzog? Exploring the Life and Work of a Pioneer of Communication Research*, Frankfurt a.M.: Peter Lang 2016.

own Institute for Motivational Research in New York in 1946, which also specialized in psychological marketing techniques and was extremely successful in the postwar period.⁵⁸⁵ He marketed products as extensions of people's personalities, supposedly enabling consumers to realize their full potential. In his book *The Psychology of Everyday Living* from 1947 Dichter predicted:

*Matters have come to such a pass that it may soon be customary to describe an individual's personality not by referring to him as one who is timid or self-conscious or characterized by any other traits, but rather, for example, as one who wears an Adam hat, drives a Plymouth car, drinks PM whiskey, and wears Arrow ties and shirts.*⁵⁸⁶

- 585 See Stefan Schwarzkopf and Rainer Gries (eds.): *Ernest Dichter and Motivation Research. New Perspectives on the Making of Post-War Consumer Culture*, New York: Palgrave Macmillan 2010.
- 586 Ernest Dichter: *The Psychology of Everyday Living*, New York: Barnes & Noble 1947, p. 213.

3.4 Welfare: Educating New People



place	Karl Marx Hof
moment	Freedom celebration
space	5 km 303 m away
time	4 h 0 min later

- In the afternoon of Saturday, May 13, 1933, the Vienna gau administration (*Gauleitung*) of the NSDAP welcomed a delegation of party members from Germany and that evening
- II.7 held a mass rally at the **Engelmann Arena**, where the case was made for Austria joining the German Reich under Adolf Hitler. The following morning, on Sunday, May 14, thousands of Home Guard (*Heimwehr*) members gathered in the gardens
- II.10 of Schönbrunn Palace for the “**Turks Deliverance Celebration**” (*Türkenbefreiungsfeier*) by the Homeland Protection League (*Heimatschutzverband*) to stand up for an independent, authoritarian Austria. But what were the Social Democrats doing on this eventful weekend, that is, the political party that had been ruling Vienna with outright majority since 1919?

On Saturday a programmatic statement by the Social Democratic party leadership was published in the *Arbeiter-Zeitung*, according to which their line from fall 1918, when the Habsburg Monarchy had come to an end along with World War I, still applied in principle: (German-)Austria should become part of the democratic Weimar Republic. It continues that this tenet simultaneously meant joining the Nazi regime, which had been established in Germany since late January 1933, was out of the question. In contrast to the Christian Social Party, which wanted to reshape the country along Fascist lines together with the Home Guards, according to this statement, the Social Democratic Workers’ Party was advocating a democratic and republican, peaceful and neutral Austria, which had to offer

asylum to German freedom and culture until Germany had liberated itself from Fascism.⁵⁸⁷

III.1.3 To turn this rhetoric into action, “festival concerts and sporting events” were held in all Viennese districts on the Sunday morning while the “Turks Deliverance Celebration” was taking place in **Schönbrunn**; these “freedom celebrations” were intended to promote “the ideas of liberty, the republic, and socialism.”⁵⁸⁸ One of the roughly fifty “freedom celebrations” occurred in the **Karl Marx Hof** in Döbling in the north of Vienna, where a protest march formed between the two inner courtyards and not only musicians but also artistic cyclists and jugglers performed. Between the acts, Social Democratic functionaries gave addresses on the idea behind the “freedom celebrations,” namely Member of Parliament Heinrich Allina, Vienna City Councillor Karl Reisinger, and Döbling District Councillor Oskar Passauer.⁵⁸⁹

Fig. 31, p. 87 Viewed pragmatically, these events were a successful strategy by the party leadership to prevent violent conflicts. The Social Democrats responded to the centralized “Turks Deliverance Celebration” with a multitude of “freedom celebrations” distributed throughout Vienna. As a result, the clashes that day primarily occurred between the police and those National Socialists who were protesting against the **Home Guard parade** from Schönbrunn into the inner city.⁵⁹⁰ This caring attitude was just as typical of the politics of “Red Vienna” as the venue of the rallies—communal public housing—and the concept of a socialist counterculture, which found expression in the “freedom celebrations.”⁵⁹¹

587 See “Österreichs staatliche Zukunft und die Sozialdemokratie” and “Weder Hitler noch Habsburg!,” in: *Arbeiter-Zeitung* (Vienna), May 13, 1933, pp. 1–2.

588 “Heute Freiheitsfeiern,” in: *Arbeiter-Zeitung* (Vienna), May 14, 1933, p. 1 [our trans.].

589 See “Die Freiheitsfeiern in den Wiener Bezirken,” in: *Arbeiter-Zeitung* (Vienna), May 15, 1933, p. 1.

590 According to the ministerial *Wiener Zeitung* (May 16, 1933, p. 4), 530 people were arrested during the day, among them 409 National Socialists and 58 Social Democrats.

591 An extensive collection of source texts on “Red Vienna” from 1919 to 1934 is offered in this edited volume by Rob McFarland, Georg Spitaler, Ingo Zechner (eds.): *The Red Vienna Sourcebook*, Rochester: Camden House 2020.

Since the Treaty of Saint-Germain-en-Laye, which was signed in 1919, had forbidden Austria from joining Germany and the Social Democratic Workers' Party had withdrawn from the Austrian federal government the following year, the capital city was the only place left where the party, which had been founded in 1889, could implement its policies. Vienna, the longstanding seat of the Habsburg Monarchy, was to be transformed into a model socialist region, which would neither become trapped in petit bourgeois reformism nor emulate the Bolshevik revolution in Russia. "Austro-Marxism," wrote its most important idea generator Otto Bauer in a leading article in the *Arbeiter-Zeitung* in 1927, was the unification of sober realpolitik and revolutionary enthusiasm.⁵⁹² In the Viennese model, this synthesis was realized primarily in an interconnected welfare program and in communal public housing, which served as infrastructure for the formation of a socialist population.

Fig. 126, p. 295

"New People" was not just a slogan in the "New Vienna" of the 1920s, but also the title (*Neue Menschen*) of a book by Max Adler published in 1924, who was another key theorist of Austro-Marxism. Unlike Historical Materialism, according to which human consciousness is defined by economic structures, this manifesto on socialist education expressed the Enlightenment ideal that through self-education people can change the society in which they live. What then is education in the socialist sense? Adler writes: "The spiritual disengagement of children from the old world of capitalism in which they were born and preparation for a new world that they will build, for the world of communism."⁵⁹³ The focus was on children and adolescents as the "builders of the coming world," as it said in a Viennese workers' song.⁵⁹⁴ Paternally instructing and maternally caring was, however, the nature of

592 See [Otto Bauer:] "Austromarxismus," in: *Arbeiter-Zeitung* (Vienna), November 3, 1927, pp. 1–2.

593 Max Adler: *Neue Menschen. Gedanken über sozialistische Erziehung*, Berlin: Laub'sche Verlagsbuchhandlung 1924, p. 63 [our trans.].

594 The lyrics of the song *Die Arbeiter von Wien* ("The Workers of Vienna") were written by Fritz Brügel (probably in 1927), the melody taken from the Russian march *White Army, Black Baron* (1920), here cited after a sound recording in the Österreichische Mediathek, 11-00983_b02 [our trans.].

the party leadership's relationship to all comrades who were to be raised toward a classless society.

Similarly typical of the educational ideal of Austro-Marxism is the final chapter of Adler's book, which focuses on the "national education" of the German philosopher Johann Gottlieb Fichte. In his *Addresses to the German Nation* from 1808, "German" was not a matter of lineage or language, but of character and mindset, according to Adler.⁵⁹⁵ Fichte's national education aimed at the "creation of an empire of reason, a social state, but by the people whom he considers qualified to do so, by the German people."⁵⁹⁶ Red Vienna, where people with diverse cultural backgrounds lived, should anticipate this "empire of reason" on a small scale. For Adler—whether in the sense of Fichte or not is another question—this was certainly not about racial supremacy. However, the educational concept of Austrian Social Democracy, whose spokesmen like Max Adler and Otto Bauer were often of Jewish descent, was unequivocally aligned with the bourgeois ideal of German high culture, as taught in grammar schools.⁵⁹⁷

This Enlightenment attitude may have been rooted in the socialization of the party chairmen, but emphasizing the cultural revolution increasingly served as a replacement for political influence. Austrian federal policy was defined by the Christian Social Party from 1920, and in Vienna the scope for action was limited to those areas that the federal constitution declared to be the responsibility of the provinces (e.g., construction law and social security). Alongside mass rallies like the annual celebration on Labor Day, which was not allowed to take place in 1933 due to the parade ban, the Workers' Party commanded a dense network of cultural organizations, which were coordinated by the Socialist Education Center (*Sozialistische Bildungszentrale*) and the Social Democratic Arts Authority (*Sozialdemokratische Kunststelle*). While the Education Center was in charge of publications, libraries, talks, and the workers' college among other things, the Arts Authority established in

595 See Adler: *Neue Menschen*, p. 183.

596 Adler: *Neue Menschen*, p. 192 [our trans.].

597 See Helmut Gruber: *Red Vienna. Experiment in Working-Class Culture 1919–1934*, New York/Oxford: Oxford University Press 1991, pp. 26, 35–36, 85–86.

Fig. 126, p. 295

With their mixture of concerts, sport performances, and addresses by party functionaries, the “freedom celebrations” of May 14, 1933, fit seamlessly into the festival culture of Red Vienna. That instead of one central mass rally some fifty local events were held was related to the aforementioned parade ban, which the federal government had only suspended for the “Turks Deliverance Celebration” that was happening at the same time.⁶⁰⁰ With the **communal public housing** that had been built across the entire city since 1919, suitable infrastructure was available to form a decentralized counter-public. Opened in 1930 and roughly a kilometer long, the Karl Marx Hof with its almost 1,400 apartments for approximately 5,000 people was one of the largest municipal housing projects in Vienna.⁶⁰¹ Its two courtyards in which the “freedom celebration” was held are connected by an over 10,000 m² square, which to the east is delimited by a façade with six superstructures in the form of red-plastered towers. Seen from the Heiligenstädter Strasse, this forecourt resembles a cour d’honneur, which in Baroque architecture served to prepare visitors for the central power, the divine majesty of the prince or princess.⁶⁰² In the case of the Karl Marx Hof, however, the cour d’honneur does not lead to a princely residence, but from the Heiligenstadt train station in the east through the **triumphal arches of the central wing** to the Hohe Warte stadium located roughly 500 meters to the west, which in the 1920s was one of the largest sports grounds in Europe and regularly attracted thousands of soccer fans.

Fig. 127, p. 297

Architectural critics pointed out that the façade design of the Karl Marx Hof came at the expense of housing quality. After all, in exchange for the machinery aesthetics of the **tower superstructures** with their flagpoles and passageways, reminiscent of Italian Futurism and Russian Constructivism, narrow,

Fig. 127, p. 297

600 See “Kein Aufmarschverbot für die Hahnenschwänzler!,” in: *Arbeiter-Zeitung* (Vienna), May 14, 1933, p. 3.

601 See *Der Karl-Marx-Hof. Die Wohnhausanlage der Gemeinde Wien auf der Hagenwiese in Heiligenstadt*, ed. Wiener Stadtbauamt, Vienna: Thalia [1930], p. 5.

602 On the cour d’honneur of Schönbrunn Palace, for example, see Richard Kurdiovsky: *Die Gärten von Schönbrunn. Ein Spaziergang durch einen der bedeutendsten Barockgärten Europas*, St. Pölten: Residenz 2005, pp. 12–19.



Fig. 127: The forecourt and central tract of the Karl Marx Hof in Vienna around 1930.
Source: Municipal and Provincial Archives of Vienna, 3.3.2.FC1.2961M.

poorly lit, and badly ventilated rooms had to be accepted.⁶⁰³ The brochure to accompany the opening quoted a maxim of Otto Wagner, whose architectural principles left a formative mark on the design of municipal public housing (*Gemeindebau*) in interwar Vienna: “artis sola domine necessitas, necessity is the only master of art.”⁶⁰⁴ Yet the “zeitgeist architect”⁶⁰⁵ Karl Ehn, who was a student of Wagner and spent his entire professional career at Vienna’s municipal planning and building office, heeded the advice of this principle when designing the Karl Marx Hof, named after the founder of Marxism, in a contradictory way. For example, while the large green spaces of the courtyards were deemed “necessary” for the communal life of its inhabitants, the “necessity” for the monumental central wing and prestigious cour d’honneur consisted in the propaganda effect on passersby. This part of the building is

603 See Helmut Wehsmann: *Das Rote Wien. Sozialdemokratische Architektur- und Kommunalpolitik 1919–1934*, 2nd ed., Vienna: Promedia 2002, pp. 398–401.

604 *Der Karl-Marx-Hof*, p. 5 [our trans.].

605 Friedrich Achleitner: “Bauten von Wagner-Schülern in der Zwischenkriegszeit” [1987], in: *Wiener Architektur. Zwischen typologischem Fatalismus und semantischem Schlamassel*, Vienna: Böhlau 1996, pp. 44–51, here p. 50 [our trans.].



Fig. 128: The bronze “Sower” by Otto Hofner in the forecourt of the Karl Marx Hof in Vienna, photographed in 1930. Source: Municipal and Provincial Archives of Vienna, 3.3.2.FC1.2564M.

relatively unimportant and dysfunctional as housing, but as a symbol for Red Vienna it continues to serve its purpose up to the present day.

Also politically significant are the sculptures in the forecourt, in the middle of which a bronze “**Sower**” by the sculptor Otto Hofner is positioned. What this muscular young man is sowing in the Karl Marx Hof are the seeds of a classless society. “We are the field, the sower, and the seed” says the second verse of the aforementioned Viennese workers’ song by Fritz Brügel.⁶⁰⁶ This “we” implies the workers who were to be raised as New People in line with Austro-Marxism. What this education comprised is clarified by the four allegorical ceramic figures by Josef Franz Riedl, which are mounted above the round arches of the central wing: “**Freedom**” is a prisoner who has broken his chains; “**Enlightenment**” a woman with short hair cut in the then popular pageboy hairstyle and books in her hands; “**Physical Culture**” a female track and field athlete in a tank top and cape who is holding a discus; and “**Welfare**” a young mother with an infant in her arm. These expressive sculptures embody not only the self-image of Red Vienna but also represent the social infrastructure of its public housing.

Fig. 128, p. 298

Fig. 129, p. 299

Fig. 130, p. 299

Fig. 131, p. 299

Fig. 132, p. 299

606 Cit. after “Die Arbeiter von Wien” [our trans.], DAT cassette, source: Österreichische Mediathek, 11-00983_b02.



Figs. 129–132: Josef Franz Riedl's ceramic figures on the central tract of the Karl Marx Hof in Vienna, photographed in 1930. From left: "Freedom" (fig. 129), "Enlightenment" (fig. 130), "Physical Culture" (fig. 131), "Welfare" (fig. 132). Source: Municipal and Provincial Archives of Vienna, 3.3.2.FC1.2141M, 3.3.2.FC1.2142M, 3.3.2.FC1.2140M, 3.3.2.FC1.2143M.

Fig. 104, p. 243

In interwar Vienna, public housing was intended to liberate workers from the **tenements** of the age of monarchy, in which several generations of the same family had to live squeezed together in overpriced apartments without their own water supply or their own toilet. However, the newly built housing complexes structured this attained freedom in line with the beliefs of the Social Democratic city government, which for economic reasons supported small young families.⁶⁰⁷ In contrast to Marxist objectives, life in the municipal public housing—with the exception of some community facilities—was not arranged collectively but rather in a petit bourgeois way. The municipal apartments comprised an anteroom with WC, an open-plan kitchen with gas oven and a sitz bath, as well as one or more rooms. The anteroom served to shield the family from the outside world and create privacy, the fitted kitchen

607 See Reinhard J. Sieder: "Wohnen und Haushalten im Gemeindebau. Politischer Diskurs, Repräsentation, Praxis, kulturelle Folgen," in: Werner Michael Schwarz, Georg Spitaler, Elke Wikidal (eds.): *Das Rote Wien. 1919–1934*, Basel: Birkhäuser 2019, pp. 234–241, here p. 235.



Fig. 133: A show room in the Advice Center for Furnishings and Domestic Hygiene of the Austrian Association for Housing Reform at the Karl Marx Hof in Vienna, photographed in 1930. Source: Municipal and Provincial Archives of Vienna, 3.3.2.FC1.2973M.

was designed according to ergonomic principles, and the dining table was intended to be a hub of communication.⁶⁰⁸

At the southern end of the Karl Marx Hof, on the corner of Heiligenstädter Strasse and Geistingergasse, the Advice Center for Furnishings and Domestic Hygiene (*Beratungsstelle für Inneneinrichtung und Wohnungshygiene*, BEST) of the Austrian Association for Housing Reform (*Österreichischer Verband für Wohnungsreform*) rented a space. Exemplary furniture and household appliances were exhibited there across three floors, including a fully furnished **show apartment** on the ground floor. Furthermore, there were regular consultation hours and lectures, which focused on diverse housing issues (e.g., how to decorate or clean an apartment).⁶⁰⁹ The Advice Center was intended to instruct renters how to make the best of their municipal apartment or row house by means of the “right” furniture and use. That living had to be learned anew was an intensive discussion that had been ongoing in Red Vienna since the early 1920s.⁶¹⁰ As the head of the Vienna

Fig. 133, p. 300

608 See Susanne Breuss: “Neue Küchen für Neue Frauen. Modernisierung der Hauswirtschaft im Roten Wien,” in: Werner Michael Schwarz, Georg Spitaler, Elke Wikidal (eds.): *Das Rote Wien. 1919–1934*, Basel: Birkhäuser 2019, pp. 242–245, here pp. 243–244.

609 See, for example, “Vorträge und Führungen der BEST im Jänner und Februar 1931,” in: *Die Wohnungsreform* (Vienna), 2/1 (January 1931), p. 7.

610 See Eva-Maria Orosz: “Wohnen lernen,” in: Werner Michael Schwarz, Georg Spitaler, Elke Wikidal (eds.): *Das Rote Wien. 1919–1934*, Basel: Birkhäuser 2019, pp. 246–253.

Settlement Office (*Siedlungsamt*), the architect Adolf Loos demanded that European citizens forget their rental apartments and learn from farmers and Americans how to live in a single-family house with garden.⁶¹¹ Whereas Loos strictly rejected any kind of ornament, Josef Frank, who was also a supporter of the settlement movement and was a member of BEST's advisory board, took the view that playful forms that went beyond the necessary were more human than the then fashionable plainness.⁶¹²

Whether settlement or perimeter block, modern or traditional, what was common to all these housing ideas was a clear division of roles within a family. The ideal way of life was embodied by the nuclear family, comprising an employed husband who was involved in politics and culture during his leisure time, and his wife who saw to the household and the children. Red Vienna positioned the mother as the interface of a comprehensive welfare program that was intended to care for people from the cradle to the grave. The person in charge of Viennese welfare was City Councillor Julius Tandler, who also taught as a professor of anatomy at the University of Vienna. His population policy aimed to improve public health by replacing private and church casework with a series of preventative health-care facilities. That Tandler's measures were partly motivated by eugenics is demonstrated, for instance, by the Marriage Advice Center (*Eheberatungsstelle*) established in 1922, where engaged couples were examined for their medical suitability for conceiving and raising children.⁶¹³ For extramarital, orphaned, or neglected children, guardianship lay with the child protective services of the City of Vienna until the age of fourteen. At the Child Adoption Center

- 611 See Adolf Loos: "Wohnen lernen!," in: *Neues Wiener Tagblatt* (Vienna), May 15, 1921, p. 8.
- 612 See Josef Frank: "Der Gschnas fürs G'müt und der Gschnas als Problem," in: Deutscher Werkbund (ed.): *Bau und Wohnung*, Stuttgart: Wedekind & Co. 1927, pp. 48–57.
- 613 See Gottfried Pirhofer and Reinhard Sieder: "Zur Konstitution der Arbeiterfamilie im Roten Wien. Familienpolitik, Kulturreform, Alltag und Ästhetik," in: Michael Mitterauer and Reinhard Sieder (eds.): *Historische Familienforschung*, Frankfurt a.M.: Suhrkamp 1982, pp. 326–368, here pp. 330–331.

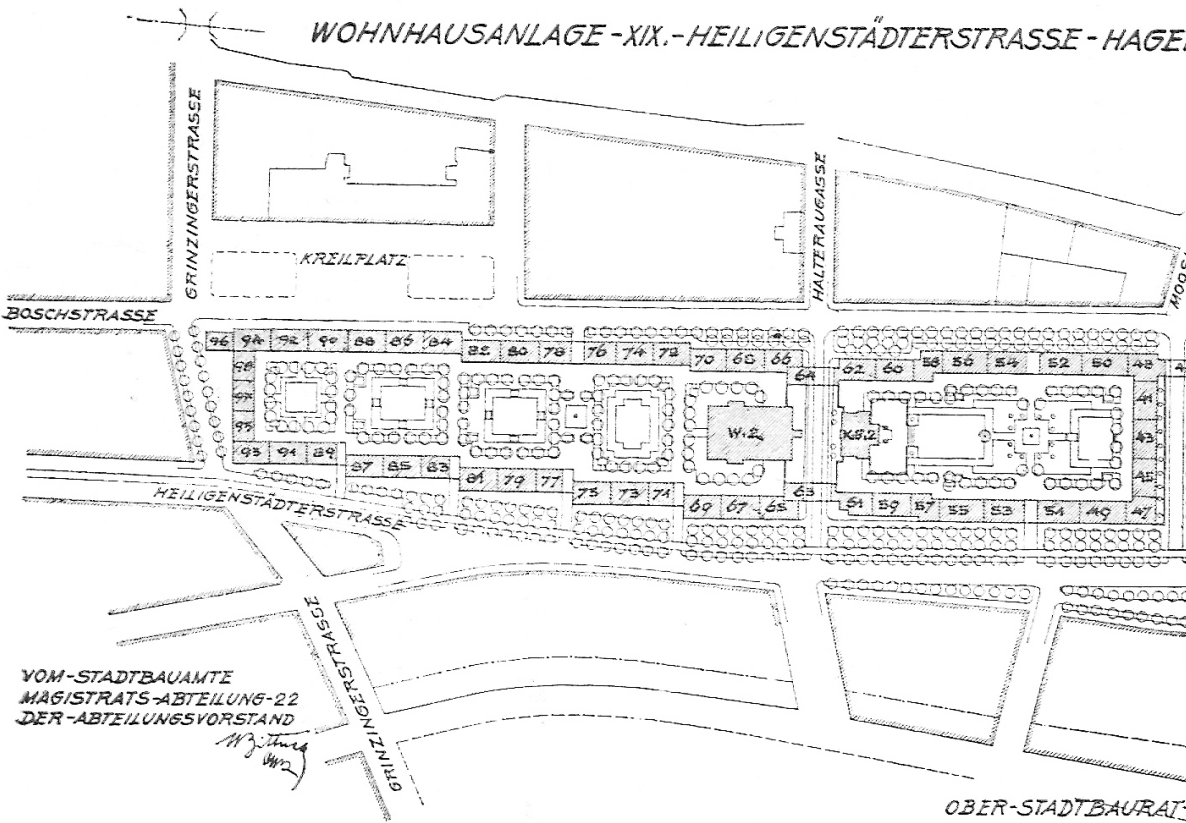

Fig. 134: Ground plan of the Karl Marx Hof in Vienna at the time of its opening in 1930, printed in *Der Karl-Marx-Hof. Die Wohnhausanlage der Gemeinde Wien auf der Hagenwiese in Heiligenstadt*, ed. Wiener Stadtbauamt, Vienna: Thalia [1930], p. 8. Source: Vienna City Library, B-344322.

(*Kinderübernahmestelle*, KÜST) that was opened in 1925, not only were pragmatic decisions made about placing children in foster families or homes, but under the management of the developmental psychologist **Charlotte Bühler** ethically questionable experiments were also carried out.⁶¹⁴

III.3.2
 Fig. 134, p. 302
 The nature of Red Vienna's welfare policy is exemplified by the **Karl Marx Hof**. In each courtyard there was a kindergarten and a launderette with adjoining baths. The southern courtyard additionally housed a school dental clinic and an advice center for mothers. In the roughly one-kilometer-long

614 See Katrin Pilz: "Mutter (Rotes) Wien. Fürsorgepolitik als Erziehungs- und Kontrollinstanz im 'Neuen Wien,'" in: Werner Michael Schwarz, Georg Spitaler, Elke Wikidal (eds.): *Das Rote Wien. 1919-1934*, Basel: Birkhäuser 2019, pp. 74-81, here p. 78.

LEGENDE

- | | |
|--|---------------------------------------|
| K.G. - KINDERGARTEN | 14 - JUGENDHEIM |
| W. - WÄSCHEREI-U.-BADEANLAGE | 15 - APOTHEKE |
| Z.KL. - ZAHNKLINIK-U.-MUTERBERATUNGSSTELLE | 17 - POSTAMT |
| 3, 5 - ÖSTERR.-VERBAND-F.-WOHNUNGSREFORM | 15, 17, 19, 21 - GESCHAFTSLOKALE |
| 5 - KONSUMGENOSSENSCHAFT | 57, 59, 61 - GASTHAUS |
| 7, 9 - GEBIETSKRANKENKASSE | 71, 73, 75, 77, 79 - GESCHAFTSLOKALE |
| | 81, 83, 85, 87 - KONSUMGENOSSENSCHAFT |
| | 71, 73 - KONSUMGENOSSENSCHAFT |
| | 91 - BIBLIOTHEK |

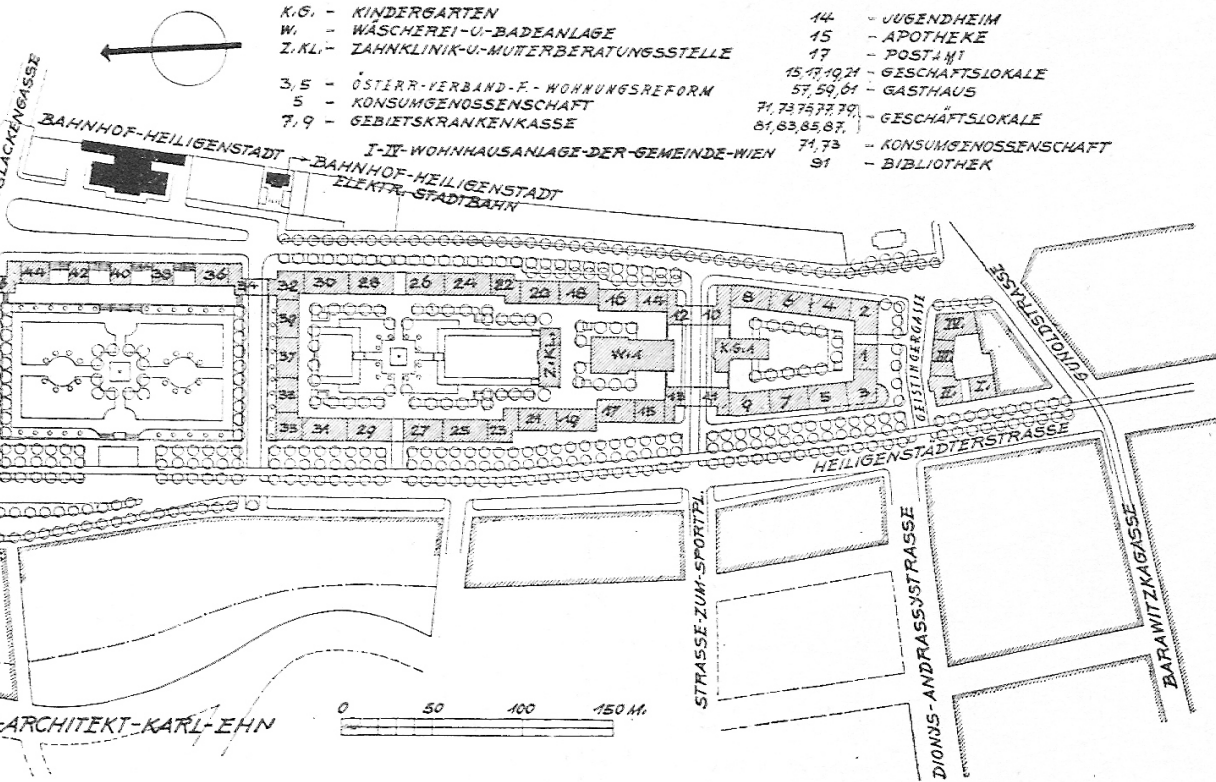

front of the building on Heiligenstädter Strasse, there were not only numerous shops and inns, but also a regional medical insurance company with outpatient clinic, a pharmacy, and a library. In other words, the Karl Marx Hof offered its inhabitants comprehensive social infrastructure with a focus on childcare facilities. In the municipal hospitals, where the vast majority of babies were born, a house call by a female employee of the welfare office was arranged after the birth had been registered, who would then give the mother a package of baby essentials and get an impression of the household. Furthermore, the mothers were encouraged to visit an advice center to receive guidance from medical specialists regarding feeding and caring for their children. If the social workers noticed serious issues, especially concerning tidiness and cleanliness in the home, they could apply to the juvenile court to have the child

or the children housed in the municipal Child Adoption Center, where a decision would be made about their future care.⁶¹⁵

Central laundrettes as in the Karl Marx Hof were included in all municipal public housing projects with over 300 apartments. Under the supervision of a “laundry foreman,” the female inhabitants could wash, dry, and iron their families’ laundry one day a month, partly with the support of appliances. Despite the fact that the majority of women were in paid work, men and children were forbidden from entering the laundrettes. As the kindergartens were not free of charge and did not take any children under the age of four, many mothers had to leave their children with relatives or neighbors on laundry day. While the laundry foreman was responsible for supervising the laundrette, the janitors were in charge of keeping the staircases and courtyards clean and tidy. For example, children were not supposed to go on the grass outside of the playgrounds and only trash cans of the “Colonia” type were allowed to be left at the garbage dumps. Moreover, once a month the households received an unannounced visit from an “apartment inspector,” who monitored the hygiene of each municipal apartment.⁶¹⁶

Consequently, the Viennese “freedom celebrations” on May 14, 1933, took place in communal apartment complexes that offered workers significantly more pleasant living conditions than the private tenement blocks during the age of monarchy. However, this improvement came at a cost: the inhabitants had to comply with the welfare and preventative system of Red Vienna. In other words, their freedom was managed according to the concepts of the Social Democratic city government. Although a petit bourgeois lifestyle prevailed in the municipal public housing projects, their political opponents, namely the newspapers of the Christian Social Party, never tired of warning against the “red strongholds” and “workers’ fortresses” in which they claimed the proletarian revolution

615 See Pirhofer and Sieder: “Zur Konstitution der Arbeiterfamilie im Roten Wien,” pp. 330–332.

616 On this paragraph, see Pirhofer and Sieder: “Zur Konstitution der Arbeiterfamilie im Roten Wien,” pp. 351–357, and Gruber: *Red Vienna*, pp. 147–155.

was being prepared.⁶¹⁷ This myth seemed to be confirmed during the civil war of February 1934, when members of the Republican Protection League entrenched themselves in some municipal public housing projects, including the Karl Marx Hof, and only surrendered after artillery fire by the Austrian Armed Forces. “The red bastille has been stormed, the outwork of Bolshevism in Central Europe,” triumphed the Christian Social *Reichspost* on February 14, 1934, after the Austrian national flag had been hoisted on Vienna City Hall.⁶¹⁸

III.1.2

- 617 See Lilli Bauer and Werner T. Bauer: “Der Karl-Marx-Hof. ‘Schaut! –, das ist ein Stück Marxismus!’,” in: Werner Michael Schwarz, Georg Spitaler, Elke Wikidal (eds.): *Das Rote Wien. 1919–1934*, Basel: Birkhäuser 2019, pp. 199–203, here pp. 201–202.
- 618 “Der Wandel im Wiener Rathause,” in: *Reichspost* (Vienna), February 14, 1934, p. 1 [our trans.].

3.5 Cancellation: “Listener Strike”



place	Vorwärts building
moment	Report on radio cancellations
space	6 km 419 away
time	1 d 20 h 0 min later

- III.3.1 That **Radio Wien broadcast the speeches** delivered at the “**Turks Deliverance Celebration**” (*Türkenbefreiungsfeier*) in the gardens of Schönbrunn Palace on May 14, 1933, provoked protests by Social Democrats. The party had flyers distributed with which listeners could cancel their radio licenses. On May 16 the *Arbeiter-Zeitung*, the main organ of Austrian Social Democracy whose editorial department was located in the building of the party’s Vorwärts publishing house at Rechte Wienzeile 97, reported that the Radio Verkehrs AG (RAVAG) had now received a letter with some 10,000 cancellations because the previous Sunday they had “transmitted the so-called ‘Turks Deliverance Celebration’ by the Austrian Homeland Protection [*Heimatschutz*], departing from the practice up to now of not broadcasting party-political events on the radio.” Indeed, the article continues, the moderator had been so shameless as to call **Ernst Rüdiger Starhemberg**, the federal leader of the Homeland Protection, “Prince Starhemberg,” even though the Law on the Abolition of the Nobility (*Adelsaufhebungsgesetz*) had been in force in Austria since 1919.⁶¹⁹
- III.1.1

Fig. 135, p. 307

It was not the first time that the Social Democratic Workers’ Party had resorted to this act of **protest against the federal government’s instrumentalization of radio**. Over 5,000 cancellations had been received by the RAVAG in April 1933 after the Viennese Home Guard (*Heimwehr*) leader and then State Secretary of Public Safety Emil Fey had given the speech “Everything for Austria” on *Radio Wien*.⁶²⁰ In it, Fey referred to the Republican

619 “Die Antwort auf den Kikeriki-Sonntag,” in: *Arbeiter-Zeitung* (Vienna), May 16, 1933, p. 2 [our trans.].

620 See “Tausende Radiohörer kündigen das Abonnement,” in: *Arbeiter-Zeitung* (Vienna), April 20, 1933, p. 1.

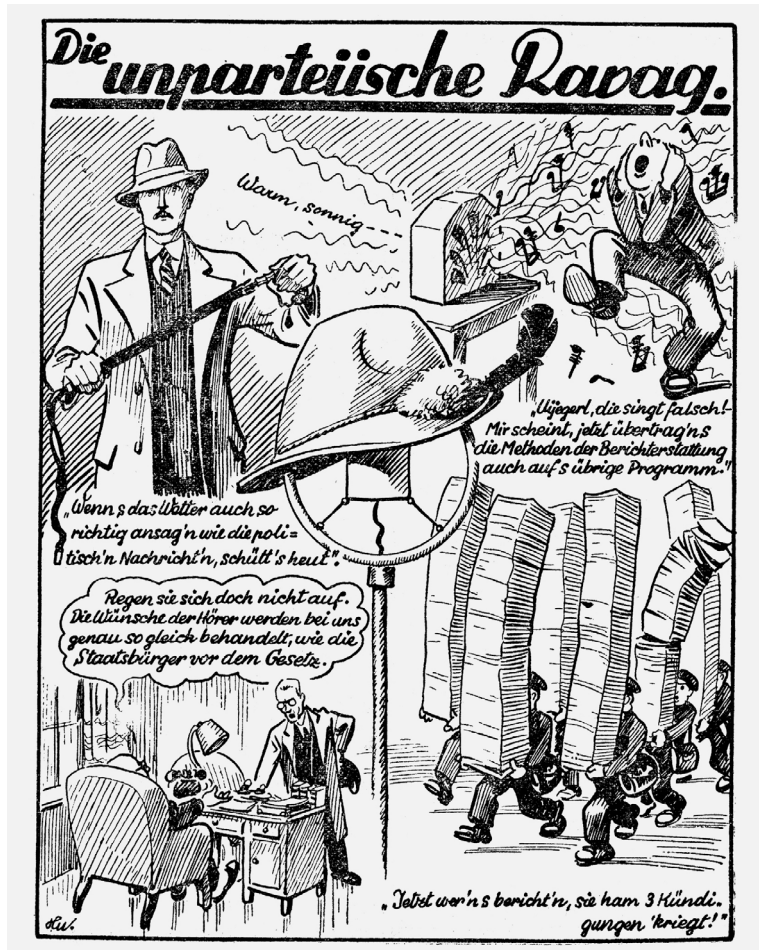

Fig. 135: Caricature on the politicization of the Austrian Radio Verkehrs AG, printed in *Das Kleine Blatt* (Vienna), May 17, 1933, p. 1. The Tyrolean hat on the microphone stands for the Home Guards, and on the bottom right towering piles of cancellations are delivered to the RAVAG. Source: Austrian National Library, 608331-D.

Protection League (*Republikanischer Schutzbund*), the paramilitary association of the Social Democratic Workers' Party, as a "heavily armed civil war organization infested with Bolsheviks," which Federal Chancellor Engelbert Dollfuss had rightly, he claimed, banned on March 31.⁶²¹ Over the course of 1933,

621 Cit. after "Alles für Österreich," in: *Reichspost* (Vienna), April 19, 1933, p. 2 [our trans.].

roughly 66,000 of the approximately 500,000 registered households canceled their radio license in protest at the biased politicization of Austrian radio.⁶²² As the RAVAG refused to recognize the collective cancellations by letter, the Social Democratic press distributed sample notices toward the end of the year, which were to be individually signed and handed in at the post office.⁶²³

To be allowed to listen to the RAVAG's program, a monthly fee of two schillings and an annual recognition fee of one and a half schillings had to be paid.⁶²⁴ That corresponded to approximately one percent of a factory worker's wage. Listening without a license was punished with hefty fines or up to a month's detention, and cancellations were possible after a year at the earliest.⁶²⁵ Although the Social Democratic party leadership campaigned for low license fees and shorter notice periods, until 1933 it did not call the Austrian radio system itself into question. Via the municipality of Vienna, the Social Democratic Workers' Party had a financial stake in the RAVAG and via various panels it also had influence over staffing and the programming format. To avoid conflicts, political topics were supposed to seldom if ever appear on *Radio Wien* and the news programs be kept as neutral as possible. In point of fact, however, the broadcasts clearly tended to favor the Christian Social Party-dominated federal government, while the program requests by the Social Democratic and National Socialist opposition were largely ignored.⁶²⁶

As a small concession to the demands for a workers' radio, in fall 1927 a weekly "chamber hour" was introduced, which was made available to the Chamber of Labor and the Chamber of Commerce for thirty minutes each. However, the

622 See Viktor Ergert: *50 Jahre Rundfunk in Österreich*.

Vol. I: 1924–1945, Vienna: Residenz 1974, p. 137.

623 See, for example, "Kündigung des Radioabonnements," in: *Arbeiter-Zeitung* (Vienna), November 28, 1933, p. 7.

624 See "Was zahlt der Radiohörer?," in: *Radiowelt* (Vienna), 9/3 (January 16, 1932), pp. 1–2.

625 See "1. Telegraphenverordnung" (§ 9, 10, 30) from September 23, 1924, in: *Bundesgesetzblatt für die Republik Österreich* (BGBl.), 77/346 (September 27, 1924), pp. 1233–1239, here pp. 1235 and 1238–1239.

626 See Theodor Venus: "'Der Sender sei die Kanzel des Volkes.'" Zur sozialdemokratischen Rundfunkpolitik in der 1. Republik," in: *Medien-Journal*, 7/1 (1983), pp. 8–19.

scripts had to be authorized by the RAVAG beforehand and even despite that, changes were often made after the fact.⁶²⁷ On May 17, 1933, in the week after the “Turks Deliverance Celebration,” the Viennese District Councillor Kamilla Gross, who was employed as a housemaid, was supposed to speak about “social policy in the household” during the Chamber of Labor’s program time. Yet according to the *Kleines Blatt*, her pre-approved presentation was removed from the program with the justification that the federal government was currently working on a reform of social legislation and there had been complaints from housewives about such shows. “The haughty philistine spirit that refuses to allow a housemaid to use the microphone and wants to clog our brains with its moldy trash,” was how the Social Democratic newspaper commented on the episode: “We don’t need a radio station governed by these spirits, a radio station by gracious lords and ladies for the stupid populace! We’d rather go without!”⁶²⁸

From spring 1933 it was clear that Austrian radio would not liberalize but go from being bourgeois conservative to Austrofascist. The radio-political compromises by the Social Democratic party leadership had been controversial from the outset in the labor movement. Specifically, the amateur radio makers (*Radiobastler*) did not want to settle for program slots on *Radio Wien* and demanded the right to set up and operate their own radio stations. In the Austrian military, especially the navy, radio technology had been in use since the turn of the century, namely for communication from transmitter to receiver, i.e., point to point. Only during World War I did radio become established as a transmission technology to reach a large number of listeners from a single transmitter. As the telegraph prerogative of 1847 was expanded to include radio units in 1905, private “radio telegraphy” and “radio telephony” now required a license in Austria.⁶²⁹

627 See Venus: “‘Der Sender sei die Kanzel des Volkes,’” p. 15.

628 “Die Ravag der ‘Gnädigen,’” in: *Das Kleine Blatt* (Vienna), May 16, 1933, p. 2 [our trans.].

629 See Theodor Venus: “Vom Funk zum Rundfunk – Ein Kulturfaktor entsteht,” in: Isabella Ackerl and Rudolf Neck (eds.): *Geistiges Leben im Österreich der Ersten Republik*, Vienna: Verlag für Geschichte und Politik 1986, pp. 379–415, here pp. 379–382.

After an Austrian subsidiary of the British Marconi Company had received a license for international radio communication in 1922, the national use of radio finally took shape in 1924. The Christian Social federal government worked on founding a privately organized but state-controlled broadcasting company, which was given the name Österreichische Radio Verkehrs AG and went on air on October 1, 1924, with its channel *Radio Wien*.⁶³⁰ However, resistance mounted against the monopolistic and centralistic organization of this “state radio.” In early 1924 a “Memorandum on the Organization of the Broadcast Message” was released by the Viennese publishing house Rubinstein under the title *Radio-Demokratie*. Its author, G.F. Hellmuth, justified his plea for “message freedom” with the argument that a financial or legal “message monopoly” was incompatible with the principles of a democracy.

It would now be the most flagrant antithesis of the most important basic idea of democracy, of the basic principle of intellectual freedom that is recognized by all civilized peoples, if an operation of such cultural significance were relinquished as a financial monopoly to a small industrial group or delegated as a legal monopoly to a licensee dependent on the respective ruling party; such an organization would mean no less than that the radio industry or the respective government had been granted a cultural dictatorship on the greatest scale; the message monopoly amounts to practically the same thing as allowing only one newspaper for all citizens whose editorial staff were selected by an industrial group or a single political party.⁶³¹

As a countermodel to the feared radio monopoly, as was then institutionalized in the form of the RAVAG, the brochure suggests the founding of an “Austrian message broadcasting cooperative” into which several program providers should combine. In the *Arbeiter-Zeitung* a leading article was published in mid-March 1924, which praised Hellmuth’s “radio democracy” as a significant contribution to the radio-political debate. It would be ideal, the editorial says, “if every citizen

630 See Venus: “Vom Funk zum Rundfunk,” pp. 408–413.

631 G.F. Hellmuth: *Radio-Demokratie! Denkschrift zur Organisation des Strahl-Rundspruches*, Vienna: Rubinstein 1924, p. 8 [our trans., emphasis in original].

had the right to set up broadcasting stations and transmit radio messages,” which, however, was not feasible due to the limited number of wavelengths. For this reason, it continued, radio had to be state regulated, but as democratically so as possible.⁶³² The same position was taken by the Viennese magazine *Radiowelt*, which was edited by the officer and radio pioneer Franz Anderle. In a leading article entitled “Radio Freedom!,” which appeared in the third issue on March 23, 1924, the ideal state of affairs was described in the same way, namely “that everyone can communicate freely and without restriction with everyone via the radio.” Yet in order to turn the radio “chaos into a cosmos,” the editorial says, it was imperative to regulate radio at national and international level in the interests of the body politic.⁶³³

Anderle, who had acquired his radio skills in the Austrian military, was himself active in the radio-amateur movement; this fact was also reflected in his magazine, which was published until 1938. Alongside program reports, *Radiowelt* mainly consisted of instructions on how to build radio receivers, small transmitters, microphones, loudspeakers, etc. In the course of the 1920s, the radio as a unit developed from a **multipart, open piece of equipment**, the use of which required a minimum of technical knowledge, into a **closed piece of furniture**, which could be operated with a few buttons.⁶³⁴ This development was in the interest of the radio industry but flew in the face of the amateur radio makers’ self-image, who did not want to be consumers of finished products and programs, but technical and content-producing agents of radio. In light of this, an array of organizations emerged: the Free Radio League (*Freier Radiobund*) in 1924, which was renamed the Workers’ Radio League of Austria (*Arbeiter-Radiobund Österreichs*, ARABÖ) in 1927, the International Amateur Radio Union in 1925, the Austrian Experimental Transmitter Association (*Österreichischer*

Fig. 115, p. 266

Fig. 116, p. 267

632 “Radiodemokratie!,” in: *Arbeiter-Zeitung* (Vienna), March 12, 1924, pp. 1–2 [our trans.].

633 “Radiofreiheit!,” in: *Radiowelt* (Vienna), 1/3 (March 23, 1924), pp. 1–2 [our trans.].

634 See Wolfgang Pensold: *Zur Geschichte des Rundfunks in Österreich. Programm für die Nation*, Wiesbaden: Springer 2018, pp. 9–14 and 33–38.



Fig. 136: A radio workshop around 1930. Source: Austrian National Library, 140.375-B.

Versuchssenderverband, ÖVSV) in 1926, and the Workers' Radio International (*Arbeiter-Radio-Internationale*) in 1927.⁶³⁵

However, the radio-amateur movement not only resisted having to depend on commercial receiver unit manufacturers. They also demanded the right to build their own radio transmitters and to operate them on short wavelengths. "The shortwave entity is undoubtedly the branch of wireless technology to which the working classes must direct the most attention," the Communist *Rote Fahne* declared in April 1930: "On shortwaves it is namely possible to wirelessly bridge extraordinarily large distances with quite simple means."⁶³⁶ That at first it was less about communicating content than producing the technical connection itself is shown, for example, by a report from the Social Democratic magazine *Rundfunk für alle* from January 1933 which provides an insight into the "secret language of amateur transmitters." The radio operator sets the amateur wavebands on the shortwave receiver to between twelve and ninety meters, listens carefully for Morse code, notes down and

635 See Primus-Heinz Kucher: "Radiokultur und Radioästhetik in Österreich 1924–1934," in: Primus-Heinz Kucher and Rebecca Unterberger: "Akustisches Drama." *Radioästhetik, Kultur und Radiopolitik in Österreich 1924–1934*, Bielefeld: Aisthesis 2013, pp. 11–39, here pp. 13–17.

636 "Gründung einer Kurzwellenarbeitsgemeinschaft," in: *Die Rote Fahne* (Vienna), April 13, 1930, p. 8 [our trans.].

translates these signals, which usually send a greeting or reply about the reception quality, and then attempts to respond.⁶³⁷

While the radio amateurs had to content themselves with decoding and sending almost imperceptible signals, members of the federal government were given the chance to speak on *Radio Wien* with increasing frequency. Besides the collective cancellations, the supporters of Social Democracy also protested using technical means by disrupting unwelcome programs with feedback. In early April 1933, the *Arbeiter-Zeitung*—already under pre-censorship—reported on complaints by the RAVAG that some listeners were turning the controls on their radios too much and were thereby interfering with the radio reception not only in their own households but also in their neighborhoods. “That is sufficient for the sensible one,” the Social Democratic party’s main organ added ironically, “he now knows precisely what he should not do and needs no further explanations.”⁶³⁸ It seems that this tactic was also used during the “Turks Deliverance Celebration” on May 14, 1933, because a comment on the live broadcast in the *Kleines Blatt* says: “The listeners drew the obvious conclusion and tried frantically to find the foreign stations, of which the feedback provided clear evidence.”⁶³⁹

The so-called “radio theory” of the German writer Bertolt Brecht, which actually comprises a couple of isolated remarks, corresponds with the demands of the workers’ radio movement. After having encouraged the transmission of more political coverage and interviews on radio in the *Berliner Börsen-Courier* in 1927, Brecht published a talk entitled “The Radio as a Communication Apparatus” in summer 1932.⁶⁴⁰ Without going into the technical difficulties, of which the radio amateurs were well aware, the text summarized the call for radio

- 637 Robert Adler: “Die Geheimsprache der Amateursender,” in: *Rundfunk für alle* (Vienna), 2/4 (January 22, 1933), p. 12 [our trans.].
- 638 “Aus der Radiowoche,” in: *Arbeiter-Zeitung* (Vienna), April 3, 1933, p. 5 [our trans.].
- 639 “Die Ravag mit dem Hahnenschwanz,” in: *Das Kleine Blatt* (Vienna), May 16, 1933, p. 9 [our trans.].
- 640 See Bertolt Brecht: “Suggestions for the Director of Radio Broadcasting” [German 1927] and “The Radio as a Communication Apparatus” [German 1932], in: *Brecht on Film and Radio*, trans. and ed. Marc Silberman, London: Bloomsbury 2000, pp. 35–36 and 41–46.

democracy and radio freedom, which had been made since the early 1920s, in this oft-quoted choice of words:

*[R]adio must be transformed from a distribution apparatus into a communications apparatus. The radio could be the finest possible communications apparatus in public life, a vast system of channels. That is, it could be so, if it understood how to receive as well as to transmit, how to let the listener speak as well as hear, how to bring him into a network instead of isolating him.*⁶⁴¹

Fig. 137, p. 315

As a model for this alternative use of radio, Brecht named in this talk his radio drama *Lindbergh's Flight*, for which Kurt Weill and Paul Hindemith had composed the music.⁶⁴² It was first performed on July 27, 1929, in the context of the **chamber-music festival in Baden-Baden** and broadcast by several German radio stations over the following two days. This so-called “radio lesson” (*Radiolehrstück*) covered the first crossing of the Atlantic Ocean in a solo, nonstop flight: the American pilot Charles Lindbergh had started in New York City on May 20, 1927, and landed at Le Bourget airport in Paris after 33.5 hours. In Brecht’s radio drama, the radio is supposed to transmit the voices of the adverse elements like the fog, the snowstorm, and sleep, whereas the part of the pilot was to be sung and experienced by the listeners themselves. However, only concert versions were transmitted on the radio, because the experiment would have required a large campaign to achieve the desired mass impact. From a technical perspective, the radio units were in any case not capable of satisfying Brecht’s demands, namely serving simultaneously as receivers and as transmitters in order to unite the many isolated “Lindberghs” into a joint “Ocean Flight” in the ether.⁶⁴³

From 1933 there could be no doubt in Germany nor in Austria that radio had established itself both technically and

641 Brecht: “The Radio as a Communication Apparatus,” p. 42.

642 See Bertolt Brecht: “Lindbergh’s Flight,” trans. John Willett [German 1930], in: *Collected Plays. Three*, ed. John Willett, London: Bloomsbury 1998, pp. 1–19, and Dieter Wöhrle: *Bertolt Brechts medienästhetische Versuche*, Cologne: Prometh 1988, pp. 45–60.

643 Brecht renamed the play *The Lindberghs’ Flight* in 1930 and *The Ocean Flight* in 1950, see the notes on “Lindbergh’s Flight” in Bertolt Brecht: *Collected Plays. Three*, ed. John Willett, London: Bloomsbury 1998, pp. 315–324.



Fig. 137: Photo of the rehearsals for the premiere of the radio drama *Lindbergh's Flight* (text: Bertolt Brecht, here second from right; music: Paul Hindemith & Kurt Weill) at the chamber-music festival in Baden-Baden on July 27, 1929. Source: Academy of Arts (Berlin), Bertolt Brecht Archive, theater documentation 2214.

in terms of content as a “distribution apparatus,” i.e., as a mass medium used by the ruling parties to their own ends. At first the opposition forces attempted to disrupt the increasingly frequent propaganda shows with acts of sabotage like the aforementioned feedback. As an alternative act of protest, Austrian Social Democracy organized the described “listener strike” with thousands of radio license cancellations. This passive resistance—preferring to cancel than to continue rebelling—is less reminiscent of Brecht’s idea of a “communications apparatus” than of the words put into the mouth of the character Bartleby by the American writer Herman Melville: “I would prefer not to.”⁶⁴⁴

Melville’s “story of Wall-Street” published in 1853 tells of a scrivener who starts working as a copyist in a New York law office. His desk stands under a small window with a view of a brick wall and is separated by a folding screen, “which might entirely isolate Bartleby from my sight, though not remove him from my voice,” as his boss, the story’s narrator, explains. Bartleby copies documents day in, day out, never leaves the office, and only survives on ginger nuts, which the office’s errand boy brings to him. One day he answers to his

644 See Herman Melville: “Bartleby, the Scrivener,” in *Putnam’s Monthly Magazine of American Literature, Science, and Art* (New York), 2 (July–December 1853), pp. 546–557 and 609–615. For an overview of philosophical interpretations from Gilles Deleuze via Giorgio Agamben to Slavoj Žižek, see Armin Beverungen and Stephen Dunne: “‘I’d prefer not to.’ Bartleby and the Excesses of Interpretation,” in *Culture and Organization*, 12/2 (2007), pp. 171–183.

superior that he “would prefer not to” help examine a paper. This “prefer not to” subsequently extends to all his tasks until he even stops writing and only stares out of the window.⁶⁴⁵

His boss’s reactions fluctuate between exasperation at the “mild effrontery” of his employee and attempts to interpret his behavior as “morbid moodiness.” As *Bartleby* does not want to leave his workplace but his presence starts to disturb the clients, the lawyer moves his firm elsewhere. The unemployed scrivener, who now sits in the staircase in front of his former office, is removed from the building on Wall Street as a vagrant and taken to the New York city jail. There he stops eating and ultimately dies. His boss only finds out later that before being employed as a copyist *Bartleby* had been a “subordinate clerk in the Dead Letter Office at Washington,” where undeliverable mail was examined and largely burnt.⁶⁴⁶

In contrast to Brecht and the radio amateurs, *Bartleby* does not demand more communication but evades every form of interaction. Instead of rebelling against his boss, telling him that he could no longer stand the interminable copying and finally wanted to do something meaningful, even creative, he insists on the right to be there unproductively. “I would prefer nothing rather than something: not a will to nothingness, but the growth of a nothingness of the will,” the French philosopher Gilles Deleuze wrote on *Bartleby*’s attitude.⁶⁴⁷ The lawyer interprets his employee’s strange behavior as the expression of a mental illness. But perhaps it is the opposite and doing nothing is in fact a remedy for the interconnected world of communication.

645 Melville: “*Bartleby, the Scrivener*,” quotes pp. 549–550.

646 Melville: “*Bartleby, the Scrivener*,” quotes pp. 553–554 and 614.

647 Gilles Deleuze: “*Bartleby; or, The Formula*” [French 1989], in: *Essays Critical and Clinical*, trans. Daniel W. Smith and Michael A. Greco, Minneapolis: University of Minnesota Press 1997 [French 1993], pp. 68–90, here p. 71.

Appendix:
The list of figures,
the list of sources,
and the short
biographies of the
Campus Medius
project team.

1. List of Figures

The figures published in this book that were created by its author or by the project team of *Campus Medius* are licensed under Creative Commons Attribution 4.0 (CC BY 4.0). This license permits unrestricted use and distribution of the respective material, provided that the creator(s), who retain(s) copyright, and the source are properly credited. The reuse of figures cited in this book from external sources may require further permissions from the rights holder(s). The obligation to research and obtain such permissions lies with the reusing party.

- Fig. 1 Screenshot of the website campusmedius.net (desktop version 2.0/2021) showing the start page with the opened menu and the selection of the page “Overview” (text: Simon Ganahl, code: Andreas Krimbacher, design: Susanne Kiesenhofer). The QR code leads to the corresponding web page. — p. 18
- Fig. 2 Screenshot of the website campusmedius.net (desktop version 1.0/2014) showing the map of Vienna from 1933 rectified to align with the underlying OpenStreetMap, the twenty-four-hour timeline from May 13, 1933, at 2 p.m., to May 14, 1933, at 2 p.m., and the opened actor-network window of the event “Aspern Airfield” (text: Simon Ganahl, back-end coding: Rory Solomon, front-end coding: Darius Daftary, design: Mallory Brennan). — p. 24
- Fig. 3 Screenshot of the website campusmedius.net (desktop version 1.0/2014) showing the opened information of the event “Radio Wien” (text: Simon Ganahl, back-end coding: Rory Solomon, front-end coding: Darius Daftary, design: Mallory Brennan). — p. 26
- Fig. 4 Mediator icons, designed by Susanne Kiesenhofer and Mallory Brennan along the lines of Otto Neurath’s International System of Typographic Picture Education (ISOTYPE), implemented in the Topology module of the website campusmedius.net (version 2.0/2021). — p. 32
- Fig. 5 Screenshot of the Topology module of the website campusmedius.net (desktop version 2.0/2021) showing the start page of the mediation “How to Use Reason: Sovereign Signs” (text: Simon Ganahl, code: Andreas Krimbacher, design: Susanne Kiesenhofer). — p. 34
- Fig. 6 The data model, developed by Simon Ganahl and Andreas Krimbacher, of the Topology module of the website campusmedius.net (version 2.0/2021). — p. 38
- Fig. 7 Screenshot of the website campusmedius.net (mobile version 2.0/2021) showing the start page with the selection of the page “Overview” (text: Simon Ganahl, code: Andreas Krimbacher, design: Susanne Kiesenhofer). — p. 40
- Fig. 8 Screenshot of the website campusmedius.net (mobile version 2.0/2021) showing the start page of the Topology module (text: Simon Ganahl, code: Andreas Krimbacher, design: Susanne Kiesenhofer). — p. 41
- Fig. 9 Screenshot of the website campusmedius.net (desktop version 2.0/2021) showing the metadata of the event “Schönbrunn Palace Gardens” in the

- Topography module (text: Simon Ganahl, code: Andreas Krimbacher, design: Susanne Kiesenhofer). — p. 42
- Fig. 10 Screenshot of the website *campusmedius.net* (desktop version 2.0/2021) showing the first results of a full-text search for the name “Dollfuss” (text: Simon Ganahl, code: Andreas Krimbacher, design: Susanne Kiesenhofer). — p. 43
- Fig. 11 Astrid Neumayr: Diagram of a venipuncture, created in a course taught by Simon Ganahl at the Vorarlberg University of Applied Sciences in 2017. — p. 49
- Fig. 12 Astrid Neumayr: Representation of looking in the mirror, created in a course taught by Simon Ganahl at the Vorarlberg University of Applied Sciences in 2017. — p. 49
- Fig. 13 Alexandra Kraller: Timeline of making espresso, created in a course taught by Simon Ganahl at the Vorarlberg University of Applied Sciences in 2017. — p. 50
- Fig. 14 David Juen: Map of a car ride, created in a course taught by Simon Ganahl at the University of Liechtenstein in 2019. — p. 50
- Fig. 15 Lina Gasperi: Visualization of an entry in the sketch book, created in a course taught by Simon Ganahl at the University of Liechtenstein in 2019. — p. 51
- Fig. 16 Mio Kobayashi: Timeline of a videoconference, created in a course taught by Simon Ganahl at the University of Liechtenstein in 2020. — p. 51
- Fig. 17 Gregorio Candelieri: Diagram of a meditation exercise, created in a course taught by Simon Ganahl at the University of Liechtenstein in 2020. — p. 52
- Fig. 18 Screenshot of the website *campusmedius.net* (desktop version 2.0/2021) showing the start page of the Topography module (text: Simon Ganahl, code: Andreas Krimbacher, design: Susanne Kiesenhofer). The QR code leads to the corresponding web page. — p. 54
- Fig. 19 Hans Frank (on the right) and Hanns Kerrl (in the middle) are welcomed by Alfred Eduard Frauenfeld (on the left) at Aspern airfield in Vienna shortly after 2 p.m. on May 13, 1933. The smiling man in the background is Roland Freisler. Source: Austrian National Library, Pz 1933 V 13/1/1C(D). — p. 57
- Fig. 20 Hans Frank lays a wreath at the Lion of Aspern in Vienna at around 3 p.m. on May 13, 1933, printed in *Deutschösterreichische Tages-Zeitung* (Vienna), May 21, 1933, pictorial supplement, p. 348. Source: Austrian National Library, 395201-D. — p. 58
- Fig. 21 Hans Frank (in the back of the car) driving by the Lassalle Hof in Vienna at around 3:30 p.m. on May 13, 1933, printed in *Die Stunde* (Vienna), May 16, 1933, p. 3. The text reads: “The ‘Undesirable Visit’ / Minister Frank and his companions return the ‘greetings’ of the red-flagged Lassalle Hof.” Source: Austrian National Library, 606233-D. — p. 60
- Fig. 22 A motorcade on the occasion of German Nazi politicians visiting Vienna on May 13, 1933, here on Mariahilfer Strasse at around 4:30 p.m. Source: Municipal and Provincial Archives of Vienna, 2.7.1.11.1.FC1.1.233. — p. 61
- Fig. 23 Advertisement for the screening of Fritz Lang’s film *The Testament of Dr. Mabuse* in eight movie theaters in Vienna on May 13, 1933, printed in *Die Stunde* (Vienna), May 13, 1933, p. 1. Source: Austrian National Library, 606233-D. — p. 63
- Fig. 24 Review of the premiere of the play *Hundred Days* (*Campo di maggio*), written by Giovacchino Forzano and Benito Mussolini, at the Burgtheater in Vienna on April 22, 1933, published in *Das interessante Blatt* (Vienna), 52/17

- (April 27, 1933), p. 16. In the photos: among others, Werner Krauss as Napoleon (on the left and top right) and Fred Hennings as Joseph Fouché (bottom right). Source: Austrian National Library, 399792-D. — p. 65
- Fig. 25 Roland Freisler (on the left) holding a speech at the National Socialist “Turks Deliverance Celebration” in the Engelmann Arena in Vienna on the evening of May 13, 1933. The picture on the right shows a police officer sent by the Austrian government to monitor the event. These photos were published in *Das interessante Blatt* (Vienna), 52/20 (May 18, 1933), p. 4. Source: Austrian National Library, 399792-D. — p. 69
- Fig. 26 Poster by the communist Association of Friends of the Soviet Union announcing the screening of Sergei Eisenstein’s *Battleship Potemkin* and Viktor Turin’s *Turksib* at the Friedensbrücken Kino in Vienna from 11 p.m. on May 13, 1933. Source: Austrian National Library, PLA16304668. — p. 73
- Fig. 27 P.T. Barnum and Edward Bernays, printed in *Der Querschnitt* (Berlin), 13/4 (April 1933), before p. 265. The caption reads: “Phineas Taylor Barnum / Edward L. Bernays / the masters of American advertising.” Source: Austrian National Library, 560198-C. — p. 75
- Fig. 28 Poster announcing the “Turks Deliverance Celebration” held by the Austrian Homeland Protection in the gardens of Schönbrunn Palace in Vienna on May 14, 1933. In the foreground a prototypical Home Guard man is depicted, in the background Count Ernst Rüdiger von Starhemberg in front of Vienna’s St. Stephen’s Cathedral. Source: Austrian National Library, PLA16304635. — p. 79
- Fig. 29 Screenshot of the Topography module of the website campusmedius.net (desktop version 2.0/2021) showing the opened information of the event “Schönbrunn Palace Gardens” and the timeline filtered from sixteen to twenty-four hours (text: Simon Ganahl, code: Andreas Krimbacher, design: Susanne Kiesenhofer). — p. 80
- Fig. 30 Screenshot of the Topography module of the website campusmedius.net (mobile version 2.0/2021) showing the opened information of the event “Tonkino Fischer” (text: Simon Ganahl, code: Andreas Krimbacher, design: Susanne Kiesenhofer). — p. 84
- Fig. 31 Photographs of the “freedom celebrations” in Vienna’s municipal housing projects on May 14, 1933, printed in *Arbeiter-Zeitung* (Vienna), May 16, 1933, p. 3. Source: Austrian National Library, 974000-D. — p. 87
- Fig. 32 Photographs of events from where the station *Radio Wien* reported live on May 14, 1933: the “Turks Deliverance Celebration” in the gardens of Schönbrunn Palace (at the top) and a relay race in the Prater park (at the bottom), printed in *Radio Wien* (Vienna), 9/34 (May 19, 1933), p. 2. Source: Austrian National Library, 607949-C. — p. 89
- Fig. 33 Screenshot of the Topography module of the website campusmedius.net (mobile version 2.0/2021) showing the opened timeline, filtered from sixteen to twenty-four hours, and the selection of the event “German Embassy” (text: Simon Ganahl, code: Andreas Krimbacher, design: Susanne Kiesenhofer). — p. 91
- Fig. 34 Austrian Home Guard men lower the flags on Schwarzenbergplatz in Vienna on the afternoon of May 14, 1933, as they march past representatives of the federal government and of the Homeland Protection,

- including Engelbert Dollfuss (second from left) and Ernst Rüdiger Starhemberg (third from left), who review and salute the paramilitary parade. Source: Austrian National Library, H 2012/1. — p. 93
- Fig. 35 Screenshot of the website *campusmedius.net* (desktop version 2.0/2021) showing the start page of the Topology module (text: Simon Ganahl, code: Andreas Krimbacher, design: Susanne Kiesenhofer). The QR code leads to the corresponding web page. — p. 96
- Fig. 36 The centralized network of the mediation “How to Use Reason: Sovereign Signs” in the Topology module of the website *campusmedius.net* (version 2.0/2021), designed by Susanne Kiesenhofer and adapted for the book edition by Stefan Amann. — p. 99
- Fig. 37 Screenshot of the Topology module of the website *campusmedius.net* (desktop version 2.0/2021) showing the abstract of the mediator “Ernst Rüdiger Starhemberg” in the mediation “How to Use Reason: Sovereign Signs” (text: Simon Ganahl, code: Andreas Krimbacher, design: Susanne Kiesenhofer). — p. 104
- Fig. 38 The Starhemberg family’s noble coat of arms from 1765. Source: Fürst Starhemberg’sche Familienstiftung (Eferding in Upper Austria). — p. 107
- Fig. 39 Ernst Rüdiger Starhemberg (ninth from the right) and Emil Fey (on his right) on the Rathausplatz in front of Vienna’s City Hall at around 8 a.m. on May 14, 1933, before laying a wreath at the monument to Count Ernst Rüdiger von Starhemberg. Source: Austrian National Library, 66.253B. — p. 108
- Fig. 40 The “Turks Deliverance Celebration” in the gardens of Schönbrunn Palace in Vienna on May 14, 1933: Ernst Rüdiger Starhemberg in front of the microphones; on his left a sound technician with headphones and a photographer with a Tyrolean hat; among the Home Guard men in the Great Parterre is the newsreel car of the Selenophon Licht- und Tonbild GmbH; in the background the Neptune Fountain and the Gloriette. Source: Austrian National Library, Pf 15.104 C9. — p. 111
- Fig. 41 Propaganda poster (1934) by the Austrian Homeland Protection with a photograph of Ernst Rüdiger Starhemberg (left) and Engelbert Dollfuss, which was taken at the “Turks Deliverance Celebration” on the garden terrace of Schönbrunn Palace in Vienna on May 14, 1933. The text reads: “Build on the new Austria / Getting to work with Dollfuss / Starhemberg.” Source: Austrian National Library, PLA16307046. — p. 112
- Fig. 42 The front page of the Viennese newspaper *Reichspost* published on May 9, 1933, with the editorial “Undesirable Visit” in the right column. Source: Austrian National Library, 393106-D. — p. 117
- Fig. 43 The state territories of the Austro-Hungarian Monarchy in 1914 (left) and the Republic of Austria in 1919 (right), represented by Stefan Amann based on open data from Wikipedia. — p. 119
- Fig. 44 Screenshot of the Topology module of the website *campusmedius.net* (mobile version 2.0/2021) showing the mediator “Undesirable Visit” in the mediation “How to Use Reason: Sovereign Signs” (text: Simon Ganahl, code: Andreas Krimbacher, design: Susanne Kiesenhofer). — p. 123
- Fig. 45 Friedrich Funder giving a speech in front of representatives of the Austrian “corporative state,” among them Kurt Schuschnigg (with glasses) and Theodor Innitzer (with skullcap) in the middle of the front row, photographed in 1935 in

- the publishing building of the *Reichspost* at Strozzigasse 8 in Vienna. Source: APA Picturedesk, 19350101_PD10677. — p. 127
- Fig. 46 The old editorial office and publishing building of the newspaper *Reichspost* at Strozzigasse 41 in Vienna around 1900. Source: Archive of the Herold Druck und Verlag GmbH (Vienna). — p. 128
- Fig. 47 The new editorial office and publishing building of the newspaper *Reichspost* at Strozzigasse 8 in Vienna in 1927. Source: Archive of the Herold Druck und Verlag GmbH (Vienna). — p. 128
- Fig. 48 Composing room of the newspaper *Reichspost* with typesetting machines in the background, photographed in the new publishing building at Strozzigasse 8 in Vienna after 1913. Source: Archive of the Herold Druck und Verlag GmbH (Vienna). — p. 129
- Fig. 49 Rotary printing press of the newspaper *Reichspost*, produced by the Schnellpressenfabrik Frankenthal, Albert & Co. AG, photographed in the old publishing building at Strozzigasse 41 in Vienna before 1913. Source: Archive of the Herold Druck und Verlag GmbH (Vienna). — p. 129
- Fig. 50 Copperplate engraving of the imperial gardens of Schönbrunn by Georg Matthäus Vischer, printed in his *Topographia Archiducatus Austriae Inferioris Moderna*, vol. 1: *Das Viertel unter Wienerwaldt*, Vienna 1672, fig. 91. Source: Vienna University Library, II-177773/1. — p. 133
- Fig. 51 Engraving of the first, not realized Schönbrunn project (1688) by Johann Bernhard Fischer von Erlach, printed in his *Entwurf einer historischen Architectur*, Vienna 1721, book IV, plate II. Source: ETH Library (Zurich), Rar 758. — p. 134
- Fig. 52 Engraving of the second, mostly realized Schönbrunn project (1696) by Johann Bernhard Fischer von Erlach, printed in his *Entwurf einer historischen Architectur*, Vienna 1721, book IV, plate III. Source: ETH Library (Zurich), Rar 758. — p. 135
- Fig. 53 Bernardo Bellotto (called Canaletto): *The Imperial Pleasure-House Schönbrunn, Garden Side (1759/60)*. Source: Kunsthistorisches Museum (Vienna), GG 1667. — p. 137
- Fig. 54 Map showing the marching routes to the assembly area of the “Turks Deliverance Celebration” by the Austrian Homeland Protection in the gardens of Schönbrunn Palace in Vienna on May 14, 1933, printed in *Weisungen für die Türkenbefreiungs-Gedenkfeier am 14. Mai 1933 in Wien*, Vienna: Österreichischer Heimatschutzverband 1933, appendix 2. Source: Vienna University Library, I-514990. — p. 138
- Fig. 55 Ludwig Rohbock and Carl Rohrich: *The Neptune Basin in the Imperial Palace Gardens of Schönbrunn in Vienna (1873)*, in the background the Gloriette. Source: Schloss Schönbrunn Kultur- und Betriebsges.m.b.H., SKB 000168. — p. 141
- Fig. 56 Panoramic photograph of the “Turks Deliverance Celebration” by the Austrian Homeland Protection in the gardens of Schönbrunn Palace in Vienna on May 14, 1933: in the lower part the Light Avenue and in the center the Great Parterre with the Neptune Fountain and the Gloriette in the background; diagonally left the Obelisk Avenue and diagonally right the Zoo Avenue; on the very left a podium or truck marked “[Laut]sprecher” (“[loud]speaker”); between the Home Guard men the recording vans of the Selenophon Licht-

- und Tonbild GmbH (on the left) and of *Fox Movietone News* (or of a freelance cameraman). Source: Austrian National Library, Pk 2839. — p. 143
- Fig. 57 Laurenz Janscha and Johann Ziegler: *The Waterfall with the Obelisk in the Imperial-Royal Gardens of Schönbrunn* (1785). Source: Austrian National Library, Z85041107. — p. 144
- Fig. 58 Layout of the menagerie in Schönbrunn by Jean-Nicolas Jadot (1755). Source: Albertina (Vienna), AZ5497. — p. 144
- Fig. 59 The new building of the Burgtheater in Vienna, which opened on the Ringstrasse in 1888, photographed around 1930. Source: Austrian National Library, 140.791 B. — p. 152
- Fig. 60 Stage and auditorium of the Burgtheater in Vienna, photographed around 1930. Source: Austrian National Library, L 5.871D. — p. 152
- Fig. 61 Colorized drawing of the return from the so-called “ladies’ carousel” (*Damenkarussell*) on January 2, 1743, a courtly tournament in which equestriennes, among them queen Maria Theresa, tried to spear wooden heads of Moors and Turks. To the right of the Winter Riding School, in front of the unfinished Michaelertrakt of the Vienna Hofburg, the Hofballhaus is located, a ballroom building that was rebuilt into the Theater nächst der Burg from the 1740s onward. Source: Wien Museum, 31669. — p. 153
- Fig. 62 The Michaelerplatz in Vienna with the Old Burgtheater (on the right), photographed in 1885. Source: Austrian National Library, Kor 73/1. — p. 154
- Fig. 63 Abraham Bosse’s frontispiece for the book *Leviathan* (London: Andrew Crooke 1651) by Thomas Hobbes. Source: Wikimedia Commons. — p. 157
- Fig. 64 Contemporary engraving of Napoleon’s oath to the constitution at the Champ de Mai held on the Champ de Mars in Paris on June 1, 1815. Source: Bibliothèque nationale de France, Collection De Vinck 9540. — p. 158
- Fig. 65 Engelbert Dollfuss (front left) and Benito Mussolini (in bathing trunks), photographed in Riccione (Italy) on August 19, 1933. Source: Austrian National Library, H 2163. — p. 161
- Fig. 66 First print of *Gott, erhalte den Kaiser* (“God Preserve the Emperor,” piano arrangement), lyrics by Lorenz Leopold Haschka, music by Joseph Haydn, premiered at the Hofburgtheater in Vienna on February 12, 1797. Source: Austrian National Library, Mus.Hs.16501. — p. 167
- Fig. 67 Francis II as Holy Roman Emperor of the German Nation (1797). Source: Austrian National Library, PORT_00048214_01. — p. 168
- Fig. 68 Francis I as Emperor of Austria (ca. 1805). Source: Austrian National Library, PORT_00048185_02. — p. 168
- Fig. 69 Autograph of August Heinrich Hoffmann von Fallersleben’s *Das Lied der Deutschen* (“The Song of the Germans”), written on Helgoland on August 26, 1841. Source: Berlin State Library, Heinrich Hoffmann von Fallersleben Papers no. 70. — p. 171
- Fig. 70 Title page of the book *Austria Above Everything If She Only Will* (1684) by Philipp Wilhelm von Hörnigk. Source: Austrian National Library, 35.Z.59. — p. 173
- Fig. 71 Propaganda poster for the Fatherland Front (*Vaterländische Front*), founded as the Austrian state party in May 1933, from summer 1933. The text reads: “Austria above everything! Our Federal Chancellor Dr. Dollfuss calls: Those who love and want to protect Austria join

- the Fatherland Front! Registration at Vienna I, Bäckerstrasse 13.”
Source: Austrian National Library, PLA16304627. — p. 174
- Fig. 72 The territory of the German Confederation in 1841 with the rivers or waters named as the border regions of Germany in Hoffmann von Fallersleben’s *Lied der Deutschen*, represented by Stefan Amann based on open data from Wikipedia. — p. 176
- Fig. 73 The ranked network of the mediation “How to Capture Life: Examining Gazes” in the Topology module of the website *campusmedius.net* (version 2.0/2021), designed by Susanne Kiesenhofer and adapted for the book edition by Stefan Amann. — p. 183
- Fig. 74 Photo report on the “Turks Deliverance Celebration” held by the Austrian Homeland Protection in Vienna on May 14, 1933, printed in *Österreichische Heimatschutzzeitung* (Vienna), 2/26 (July 1, 1933), supplement “Wehrfront im Bild,” p. 4. Source: Austrian National Library, 633589. — p. 186
- Fig. 75 Propaganda poster by the Austrian Homeland Protection from 1933. The text reads: “Austria for the Austrians / this is what Starhemberg wants—this is what the Homeland Protection wants!” Source: Austrian National Library, PLA16311227. — p. 189
- Fig. 76 Ernst Rüdiger Starhemberg (at the front with bull pizzle), Engelbert Dollfuss (out of sight on his right), and Emil Fey (behind him) inspecting the Home Guard troops at the “Turks Deliverance Celebration” in the gardens of Schönbrunn Palace in Vienna on May 14, 1933, printed in *Österreichische Heimatschutzzeitung* (Vienna), 2/21 (May 27, 1933), supplement “Wehrfront im Bild,” p. 1. Source: Austrian National Library, 633589. — p. 191
- Fig. 77 Contemporary copperplate engraving showing the return of the Holy Roman Emperor Leopold I to Vienna on October 1, 1658, after his coronation in Frankfurt am Main. Source: Wien Museum, 199057. — p. 195
- Fig. 78 Engraving by Jan Thomas from 1667 showing Leopold I in theatrical costume. Source: Kunsthistorisches Museum (Vienna), GG 9135. — p. 196
- Fig. 79 Francis Joseph I in uniform as Colonel-in-Chief of the Kaiserjäger (1868). Source: Austrian National Library, Pf 19000 E 35 Var. — p. 196
- Fig. 80 Austrian Home Guard troops marching from Schönbrunn Palace to Schwarzenbergplatz in Vienna on May 14, 1933, here along Mariahilfer Strasse near the Technical Museum. At the head of the paramilitary parade: Ernst Rüdiger Starhemberg (in the center) with Emil Fey (on his right) and Richard Steidle (on his left). Source: Austrian National Library, H 2012. — p. 197
- Fig. 81 Austrian Home Guard troops marching from Schönbrunn Palace to Schwarzenbergplatz in Vienna on May 14, 1933, here at around noon on the upper Mariahilfer Strasse near the Westbahnhof train station. At the head: Ernst Rüdiger Starhemberg (in the center saluting) with Emil Fey (on his right) and Richard Steidle (on his left). On the right edge of the picture: a cameraman filming the paramilitary parade. Source: Austrian National Library, 66.287 B. — p. 200
- Fig. 82 Two methods for recording optical sound on film: in variable-density format (on the left) and in variable-area format (on the right), printed in *Radio-Amateur* (Vienna), 9/2 (February 1932), p. 121. Source: Vienna University Library, I-458300. — p. 202

- Fig. 83 A Bell & Howell 2709 35 mm movie camera from 1922 with a double-compartment film magazine, lens turret, and side viewfinder, photographed by Adam J. Wilt in 2012. Source: adamwilt.com. — p. 204
- Fig. 84 Mechanics of a Bell & Howell 2709 35 mm movie camera from 1922, photographed by Adam J. Wilt in 2012. Source: adamwilt.com. — p. 204
- Fig. 85 Screenshot of the Topology module of the website campusmedius.net (desktop version 2.0/2021) showing the abstract of the mediator “Bell & Howell 2709” in the mediation “How to Capture Life: Examining Gazes” (text: Simon Ganahl, code: Andreas Krimbacher, design: Susanne Kiesenhofer). — p. 206
- Fig. 86 Intertitle of the final piece “Austria!” in the *N.S. Ton-Bild-Bericht Nr. 2*, a 35 mm sound film published by the NSDAP’s Reich Propaganda Headquarters in Berlin in summer 1933, here after a VHS copy. Source: Film Archive of the Federal Archives (Berlin), K 172392-1. — p. 211
- Fig. 87 Still from the piece “Austria!” in the *N.S. Ton-Bild-Bericht Nr. 2*, a 35 mm sound film published by the NSDAP’s Reich Propaganda Headquarters in Berlin in summer 1933, here after a VHS copy: Hans Frank (second from right) addresses Alfred Eduard Frauenfeld (on his left) in the foyer of the Adolf Hitler House at Hirschengasse 25 in Vienna on the afternoon of May 13, 1933. Source: Film Archive of the Federal Archives (Berlin), K 172392-1. — p. 211
- Fig. 88 Still from the piece “Austria!” in the *N.S. Ton-Bild-Bericht Nr. 2*, a 35 mm sound film published by the NSDAP’s Reich Propaganda Headquarters in Berlin in summer 1933, here after a VHS copy: storm troopers marching past Adolf Hitler and Ernst Röhm. Source: Film Archive of the Federal Archives (Berlin), K 172392-1. — p. 212
- Fig. 89 Still from the piece “Austria!” in the *N.S. Ton-Bild-Bericht Nr. 2*, a 35 mm sound film published by the NSDAP’s Reich Propaganda Headquarters in Berlin in summer 1933, here after a VHS copy: a Nazi rally in the Engelmann Arena in Vienna on May 1, 1933. Source: Film Archive of the Federal Archives (Berlin), K 172392-1. — p. 212
- Fig. 90 Instructions on how to edit film without producing unwanted sound effects, printed in Fritz Fischer and Hugo Lichte (eds.): *Tonfilm. Aufnahme und Wiedergabe nach dem Klangfilm-Verfahren (System Klangfilm-Tobis)*, Leipzig: Hirzel 1931, fig. 341. Source: Austrian Central Library for Physics (Vienna), 1755. — p. 214
- Fig. 91 Photograph of Vsevolod Meyerhold’s staging of the play *Le cocu magnifique* by Fernand Crommelynck in Moscow in 1922; the Constructivist set was designed by Lyubov Popova. Source: Russian State Archives of Literature and Art (RGALI, Moscow), fund 1923 inventory 2 folder 2262 p. 4. — p. 217
- Fig. 92 Poster for the German version of Sergei Eisenstein’s film *Battleship Potemkin* from 1926. Source: Vienna City Library, P-42361. — p. 219
- Fig. 93 Poster for the Viennese premiere of Viktor Turin’s film *Turksib* on April 4, 1930. Source: Vienna City Library, P-42133. — p. 221
- Fig. 94 Still from Fritz Lang’s film *The Testament of Dr. Mabuse* (1933): the mysterious man behind the curtain instructs his subordinates in the control center. Source: Film Archive of the Federal Archives (Berlin), BSP 26989-12. — p. 224
- Fig. 95 Still from Fritz Lang’s film *The Testament of Dr. Mabuse* (1933): Kent (Gustav Diessl) and Lilli (Wera Liessem) gaze behind the curtain in the control center. Source: Film Archive of the Federal Archives (Berlin), BSP 26989-12. — p. 224

- Fig. 96 Still from Fritz Lang's film *The Testament of Dr. Mabuse* (1933): the man behind the curtain in the control center turns out to be a dummy with microphone and loudspeaker. Source: Film Archive of the Federal Archives (Berlin), BSP 26989-12. — p. 224
- Fig. 97 The auditorium on the ground floor of Hotel Central at Taborstrasse 8 in Vienna, where the Budapester Orpheum Society performed from 1903 to 1913. Source: Schick Hotels Betriebs GmbH (Vienna). — p. 226
- Fig. 98 The auditorium of the Central Kino at Taborstrasse 8 in Vienna in 1925. Source: Municipal and Provincial Archives of Vienna, 1.3.2.104.A11.2.Zentralkino. — p. 228
- Fig. 99 An AEG projector for 35 mm film with an optical sound projector by Klangfilm GmbH, printed in Fritz Fischer and Hugo Lichte (eds.): *Tonfilm. Aufnahme und Wiedergabe nach dem Klangfilm-Verfahren (System Klangfilm-Tobis)*, Leipzig: Hirzel 1931, fig. 242. Source: Austrian Central Library for Physics (Vienna), 1755. — p. 232
- Fig. 100 The so-called "Blatthaller," an electrodynamic loudspeaker by Siemens & Halske, printed in Fritz Fischer and Hugo Lichte (eds.): *Tonfilm. Aufnahme und Wiedergabe nach dem Klangfilm-Verfahren (System Klangfilm-Tobis)*, Leipzig: Hirzel 1931, fig. 155. Source: Austrian Central Library for Physics (Vienna), 1755. — p. 232
- Fig. 101 The UFA Ton Kino, located on the ground floor of Hotel Central at Taborstrasse 8 in Vienna, photographed on April 13, 1944. Source: Austrian National Library, 162.307A(B). — p. 234
- Fig. 102 Screenshot of the Topology module of the website campusmedius.net (mobile version 2.0/2021) showing the mediator "'Lick Me in the Ass!'" in the mediation "How to Capture Life: Examining Gazes" (text: Simon Ganahl, code: Andreas Krimbacher, design: Susanne Kiesenhofer). — p. 238
- Fig. 103 Stone carving from late antiquity with symbolic representations of means to repel the "evil eye," among them a man with a Phrygian cap and exposed buttocks (top left), printed in Frederick Thomas Elworthy: *The Evil Eye. An Account of this Ancient & Widespread Superstition*, London: John Murray 1895, fig. 24. Source: Internet Archive. — p. 240
- Fig. 104 The layout of municipal apartments built in Vienna in the 1920s (left) compared to typical Viennese tenements from the time before World War I with rooms facing onto a narrow air well (right), printed in *Der Aufbau* (Vienna), 1/4 (1926), p. 54. Source: Austrian National Library, 558249-C. — p. 243
- Fig. 105 The Lassalle Hof in Vienna, photographed from the Lassallestrasse in 1926. Source: Municipal and Provincial Archives of Vienna, 3.3.2.FC1.407M. — p. 245
- Fig. 106 The distributed network of the mediation "How to Speak Up: Governed Transmissions" in the Topology module of the website campusmedius.net (version 2.0/2021), designed by Susanne Kiesenhofer and adapted for the book edition by Stefan Amann. — p. 249
- Fig. 107 Engelbert Dollfuss (at the microphones) and Ernst Rüdiger Starhemberg (behind him) on the garden terrace of Schönbrunn Palace in Vienna at the "Turks Deliverance Celebration" on May 14, 1933 (numbers added): (1) carbon microphone (model unknown); (2) dynamic microphone (probably a Western Electric 618A); (3) carbon microphone (Reisz); (4) carbon microphone (Reisz) and above it a dynamic microphone (model unknown);

- (5) possibly a microphone by the Selenophon Licht- und Tonbild GmbH.
Source: Austrian National Library, 106.661 B. — p. 251
- Fig. 108 Screenshot of the Topology module of the website campusmedius.net (desktop version 2.0/2021) showing the abstract of the mediator “Mikes, Cables, Transmitters” in the mediation “How to Speak Up: Governed Transmissions” (text: Simon Ganahl, code: Andreas Krimbacher, design: Susanne Kiesenhofer). — p. 254
- Fig. 109 Recording van of the Austrian Radio Verkehrs AG, called “transmitter car” (*Übertragerauto*), printed in *Radio Wien* (Vienna), 11/1 (September 28, 1934), p. 22. Source: Austrian National Library, 607949-C. — p. 258
- Fig. 110 The U7 device for recording optical sound, produced by the Viennese Selenophon GmbH, in the “transmitter car” (*Übertragerauto*) of the Austrian Radio Verkehrs AG, printed in *Radio Wien* (Vienna), 11/1 (September 28, 1934), p. 23. Source: Austrian National Library, 607949-C. — p. 258
- Fig. 111 Cross sections of the carbon microphone launched by Eugen Reisz in Berlin in 1924, printed in Fritz Fischer and Hugo Lichte (eds.): *Tonfilm. Aufnahme und Wiedergabe nach dem Klangfilm-Verfahren (System Klangfilm-Tobis)*, Leipzig: Hirzel 1931, fig. 150. Source: Austrian Central Library for Physics (Vienna), 1755. — p. 260
- Fig. 112 The “shortwave broadcaster car” (*Kurzwellen-Senderauto*) of the Austrian Radio Verkehrs AG, printed in *Radio Wien* (Vienna), 11/1 (September 28, 1934), p. 22. Source: Austrian National Library, 607949-C. — p. 261
- Fig. 113 The shortwave transmitter in the “broadcaster car” (*Senderauto*) of the Austrian Radio Verkehrs AG, printed in *Radio Wien* (Vienna), 11/1 (September 28, 1934), p. 22. Source: Austrian National Library, 607949-C. — p. 261
- Fig. 114 The long-distance lines of radio broadcasting in Germany and Austria in 1932 (arrows = transmitters), printed in *Radio-Amateur* (Vienna), 9/7 (July 1932), p. 439. Source: Vienna University Library, I-458300. — p. 262
- Fig. 115 Radio set with three tubes and headphones produced by the Viennese company Schrack around 1925. Source: Austrian National Library, L 15.914-C. — p. 266
- Fig. 116 Radio set with six tubes and loudspeaker by the brand Berliner from 1933. Source: Austrian National Library, 223.153-B. — p. 267
- Fig. 117 Flyer (ca. 1934) of the Center of Economic-Psychological Research, founded by Paul Lazarsfeld in Vienna in 1931. The text reads: “We have investigated” followed by products ranging from beer and coffee to radio and wool. Source: Paul F. Lazarsfeld Archive (University of Vienna), blue folders 131 WiFo-1. — p. 268
- Fig. 118 On November 4, 1932, the magazine *Radio Wien* reported on the results of the audience survey conducted by the Center of Economic-Psychological Research for the Austrian Radio Verkehrs AG. Source: Austrian National Library, 607949-C. — p. 273
- Fig. 119 Graph of fifty-two subjects rating a radio broadcast with Paul Lazarsfeld and Frank Stanton’s “program analyzer,” represented in Jack N. Peterman: “The ‘Program Analyzer.’ A New Technique in Studying Liked and Disliked Items in Radio Programs,” in: *The Journal of Applied Psychology*, 24/6 (1940), pp. 728–741, here p. 733. Source: Vienna University Library, NEURATH-5387. — p. 277

- Fig. 120 Screenshot of the Topology module of the website *campusmedius.net* (mobile version 2.0/2021) showing the mediator “Torches of Freedom” in the mediation “How to Speak Up: Governed Transmissions” (text: Simon Ganahl, code: Andreas Krimbacher, design: Susanne Kiesenhofer). — p. 280
- Fig. 121 Advertisement for the Beech-Nut Packing Company from around 1930, contained in the archives of the Beech-Nut Packing Company. Source: Arkell Museum (Canajoharie, NY). — p. 282
- Fig. 122 Edith Lee walking on Fifth Avenue in New York at around noon on March 31, 1929, as one of the young women whom Edward Bernays hired on behalf of the American Tobacco Company to smoke in public at the Easter parade. Source: Library of Congress (Washington, DC), Prints & Photographs LOT 15019 no. 13. — p. 284
- Fig. 123 Eugène Delacroix: *La Liberté guidant le peuple* (1830). Source: Musée du Louvre (Paris), Département des Peintures RF 129. — p. 285
- Fig. 124 The Statue of Liberty in New York’s harbor, photographed around 1930. Source: National Archives and Records Administration (Washington, DC), 594414. — p. 285
- Fig. 125 Diagram on the structure of purchase actions, represented in Paul F. Lazarsfeld: “The Psychological Aspect of Market Research,” in: *Harvard Business Review*, 13/1 (1934), pp. 54–71, here p. 65. Source: Bielefeld University Library, 990/0096739+01. — p. 288
- Fig. 126 City map of Vienna from 1932 showing the municipal housing projects (red) and settlements (orange), printed as an appendix to the book *Das Neue Wien. Ein Album mit Plan*, Vienna: Elbemühl 1932. Source: Vienna City Library, A-79091. — p. 295
- Fig. 127 The forecourt and central tract of the Karl Marx Hof in Vienna around 1930. Source: Municipal and Provincial Archives of Vienna, 3.3.2.FC1.2961M. — p. 297
- Fig. 128 The bronze “Sower” by Otto Hofner in the forecourt of the Karl Marx Hof in Vienna, photographed in 1930. Source: Municipal and Provincial Archives of Vienna, 3.3.2.FC1.2564M. — p. 298
- Fig. 129 Josef Franz Riedl’s ceramic figure “Freedom” on the central tract of the Karl Marx Hof in Vienna, photographed in 1930. Source: Municipal and Provincial Archives of Vienna, 3.3.2.FC1.2141M. — p. 299
- Fig. 130 Josef Franz Riedl’s ceramic figure “Enlightenment” on the central tract of the Karl Marx Hof in Vienna, photographed in 1930. Source: Municipal and Provincial Archives of Vienna, 3.3.2.FC1.2142M. — p. 299
- Fig. 131 Josef Franz Riedl’s ceramic figure “Physical Culture” on the central tract of the Karl Marx Hof in Vienna, photographed in 1930. Source: Municipal and Provincial Archives of Vienna, 3.3.2.FC1.2140M. — p. 299
- Fig. 132 Josef Franz Riedl’s ceramic figure “Welfare” on the central tract of the Karl Marx Hof in Vienna, photographed in 1930. Source: Municipal and Provincial Archives of Vienna, 3.3.2.FC1.2143M. — p. 299
- Fig. 133 A show room in the Advice Center for Furnishings and Domestic Hygiene of the Austrian Association for Housing Reform at the Karl Marx Hof in Vienna, photographed in 1930. Source: Municipal and Provincial Archives of Vienna, 3.3.2.FC1.2973M. — p. 300

- Fig. 134 Ground plan of the Karl Marx Hof in Vienna at the time of its opening in 1930, printed in *Der Karl-Marx-Hof. Die Wohnhausanlage der Gemeinde Wien auf der Hagenwiese in Heiligenstadt*, ed. Wiener Stadtbauamt, Vienna: Thalia [1930], p. 8. Source: Vienna City Library, B-344322. — p. 302
- Fig. 135 Caricature on the politicization of the Austrian Radio Verkehrs AG, printed in *Das Kleine Blatt* (Vienna), May 17, 1933, p. 1. The Tyrolean hat on the microphone stands for the Home Guards, and on the bottom right towering piles of cancellations are delivered to the RAVAG. Source: Austrian National Library, 608331-D. — p. 307
- Fig. 136 A radio workshop around 1930. Source: Austrian National Library, 140.375-B. — p. 312
- Fig. 137 Photo of the rehearsals for the premiere of the radio drama *Lindbergh's Flight* (text: Bertolt Brecht, here second from right; music: Paul Hindemith & Kurt Weill) at the chamber-music festival in Baden-Baden on July 27, 1929. Source: Academy of Arts (Berlin), Bertolt Brecht Archive, theater documentation 2214. — p. 315

2. List of Sources

The texts published in this book that were created by its author are licensed under Creative Commons Attribution 4.0 (CC BY 4.0). This license permits unrestricted use and distribution of the respective material, provided that the creator(s), who retain(s) copyright, and the source are properly credited. The reuse of texts cited in this book from external sources may require further permissions from the rights holder(s). The obligation to research and obtain such permissions lies with the reusing party.

2.1 Archival Documents

Archive of the Burgtheater (Vienna):

- Promptbook (609 R) *Hundert Tage*, Vienna: Georg Marton 1933.

Austrian National Library:

- *Gesamtplan von Wien*, Vienna: Freytag & Berndt 1933 (Map Department, K III 101617).
- *Gott, erhalte den Kaiser! Verfasset von Lorenz Leopold Haschka, In Musik gesetzt von Joseph Haydn, Zum ersten Mahle abgesungen den 12. Februar, 1797* (first print, Department of Music, Mus.Hs. 16501).
- Hoffmann von Fallersleben: *Das Lied der Deutschen. Arrangirt für die Singstimme mit Begleitung des Pianoforte oder der Gitarre*, Hamburg: Hoffmann und Campe, September 1, 1841 (reprint from 1923, Department of Music, MS9451-4°).

Austrian State Archives:

- Correspondence between the Austrian Homeland Protection, the Palace Captainship Schönbrunn, and the Federal Ministry of Trade and Transport on the organization of the “Turks Deliverance Celebration” in Schönbrunn on May 14, 1933 (ÖStA/AdR, BM.f.H.u.V., GZ 53, Z 61.738-1933 and ÖStA/AdR, SHS 820/1933, Kt. 86).
- Documentation of the census in Austria-Hungary in 1910 (ÖStA/AVAFHKA, MdI, Allg. Reihe, Zl. 42837/1910).
- Letter by Joseph II to Prince Khevenhüller from March 23, 1776, among other things about the renaming of the Theater nächst der Burg (ÖStA/HHStA, KA Handbillete, Akten 1).
- Minutes of the Austrian government’s cabinet meeting from December 13, 1929, among other things about the change of the national anthem (ÖStA/AdR, MRang, MR 1. Rep, MRP no. 603).
- Reports by the Federal Police Headquarters on the “Turks Deliverance Celebrations” in Vienna on May 13 and 14, 1933 (ÖStA/AdR, BKA-I, 148.459/33).

Collection of Biographical Records (University of Vienna):

- Personal chronicle (vol. 1: 1906–1937) by the farmer Franz Bauer from Neukirchen an der Wild in Lower Austria.

Edward L. Bernays Papers (Library of Congress, Washington, DC):

- Bernays, Edward L.: “Mass Psychology and the Consumer” (speech given in Boston on September 22, 1930, box I:422).
- Documentation of the campaign “torches of freedom” (boxes I:84–88 and I:519–522).
- Letter by Sigmund Freud to Edward Bernays from May 11, 1924 (box III:1).

Filmarchiv Austria:

- *Bell & Howell Standard Professional 35mm Cameras Specifications*, Chicago: Bell & Howell 1943.
- Data sheet (5860/1) on the 35 mm film “Die Türkenbefreiungsfeier des österreichischen Heimatschutzes in Wien,” in: *Jahresschau 1933 der Bundespolizeidirektion in Wien. Eine Chronik im Laufbild* (JS 1933/8).

Municipal and Provincial Archives of Vienna:

- Historical registration records on Heinrich Moses Lipsker, born in Vienna on July 23, 1879.
- Records on the Central Kino, the later UFA Ton Kino, at Taborstrasse 8 in 1020 Vienna (WStLA, M.Abt. 104, A11, Zentralkino and WStLA, Reichsfilmkammer, Aussenstelle Wien, A1 – Kinoakten: 135 – UFA-Theater).
- Records on the Friedensbrücken Kino at Klosterneuburger Strasse 33 in 1200 Vienna (WStLA, M.Abt. 471, A3/1, Friedensbrücken-Kino).

Paul Felix Lazarsfeld Papers (Butler Library, Columbia University, New York):

- [Lazarsfeld, Paul Felix: “Bedürfnis”] (20-page typescript, box 33, folder 1).
- [Lazarsfeld, Paul Felix:] “Der Gegenstand der Wirtschaftspsychologie” (24-page typescript, box 35, folder 27).
- [Lazarsfeld, Paul Felix:] “Hörerbefragung der Ravag” (52-page typescript, box 35, folder 26).

Political Archive of the Federal Foreign Office (Berlin):

- Memorandum of March 22, 1933, on a speech held by Hans Frank on the Munich radio station (Office of the Reich Minister, reference 16: Austria, R 28392).

Theatermuseum (Vienna):

- *Burgtheater Offizielles Programm* [of the play *Hundert Tage*], Vienna: Weiner [1933].

The British Library:

- *Hymn for the Emperor Francis. Composed by Dr. Haydn & Sung at the public Theatres at Vienna in the manner of God Save Great George Our King in England. Set as a Duet & Chorus with a Piano Forte. Accompaniment by I.B. Cimator, London: Monzani & Cimator [ca. 1800], Digital Store Tyson P.M.15.(13.).*

Vienna City Library:

- “Die lebende Photographie,” Vienna: Philipp & Kramer 1896 (flyer, Printed Works Collection, E-109891).

2.2 Books and Brochures

Primary Literature

- Adler, Max: *Neue Menschen. Gedanken über sozialistische Erziehung*, Berlin: Laub'sche Verlagsbuchhandlung 1924.
- Ballhausen, Thomas and Paolo Caneppele (eds.): *Entscheidungen der Wiener Filmzensur. 1929–1933*, Vienna: Filmarchiv Austria 2003.
- Barnum, Phineas Taylor: *Barnum, the Yankee Showman and Prince of Humbugs. Written by himself*, London: Piper 1855.
- Beheim, Michael: *Buch von den Wienern. 1462–1465*, ed. Theodor Georg von Karajan, Vienna: Rohrmann 1843.
- Bernays, Edward L.: *Biography of an Idea. Memoirs of Public Relations Counsel Edward L. Bernays*, New York: Simon and Schuster 1965.
- Bernays, Edward L.: *Crystallizing Public Opinion*, New York: Horace Liveright 1923.
- Bernays, Edward L.: *Propaganda*, New York: Horace Liveright 1928.
- Brecht, Bertolt: “Lindbergh's Flight,” trans. John Willett [German 1930], in: *Collected Plays. Three*, ed. John Willett, London: Bloomsbury 1998, pp. 1–19.
- Brecht, Bertolt: “Suggestions for the Director of Radio Broadcasting” [German 1927], in: *Brecht on Film and Radio*, trans. and ed. Marc Silberman, London: Bloomsbury 2000, pp. 35–36.
- Brecht, Bertolt: “The Radio as a Communication Apparatus” [German 1932], in: *Brecht on Film and Radio*, trans. and ed. Marc Silberman, London: Bloomsbury 2000, pp. 41–46.
- Cantril, Hadley and Gordon W. Allport: *The Psychology of Radio*, New York/London: Harper & Brothers 1935.
- [D'Argenville, Antoine Joseph Dézallier:] *La théorie et la pratique du jardinage*, Paris: Jean Mariette 1709.

- “Das ‘Linzer Programm’ der Sozialdemokratischen Arbeiterpartei Österreichs, 1926,” in: Klaus Berchtold (ed.): *Österreichische Parteiprogramme 1868–1966*, Vienna: Verlag für Geschichte und Politik 1967, pp. 247–264.
- Der Karl Marx-Hof. Die Wohnhausanlage der Gemeinde Wien auf der Hagenwiese in Heiligenstadt*, ed. Wiener Stadtbauamt, Vienna: Thalia [1930].
- “Der Spielplan des Burgtheaters,” in: *Almanach der österreichischen Bundestheater für das Spieljahr 1932/33*, Vienna: Wirtschafts-Zeitungs-Verlags-Ges.m.b.H. 1933, pp. 17–22.
- Dichter, Ernest: *The Psychology of Everyday Living*, New York: Barnes & Noble 1947.
- Eisenstein, Sergei: “Organic Unity and Pathos in the Composition of *Potemkin*” [Russian 1939], in: *Notes of a Film Director*, ed. R. Yurenev and G. Ivanov-Mumjiev, trans. X. Danko, Moscow: Foreign Languages Publishing House 1959, pp. 53–62.
- Eisenstein, Sergei: “The Fourth Dimension in Cinema” [Russian 1929], in: *Selected Works. Vol. 1: Writings, 1922–34*, ed. and trans. Richard Taylor, London: BFI 1988, pp. 181–194.
- Eisenstein, Sergei: “The Montage of Attractions” [Russian 1923], in: *Selected Works. Vol. 1: Writings, 1922–34*, ed. and trans. Richard Taylor, London: BFI 1988, pp. 33–38.
- Eisenstein, Sergei: “The Montage of Film Attractions” [Russian 1924], in: *Selected Works. Vol. 1: Writings, 1922–34*, ed. and trans. Richard Taylor, London: BFI 1988, pp. 39–58.
- Eisenstein, Sergei: “The Problem of the Materialist Approach to Form” [Russian 1925], in: *Selected Works. Vol. 1: Writings, 1922–34*, ed. and trans. Richard Taylor, London: BFI 1988, pp. 59–64.
- Forzano, Giovacchino: *Campo di maggio. Drama in tre atti*, Florence: Barbèra 1931.
- Forzano, Giovacchino: “La mia collaborazione teatrale con Benito Mussolini,” in: *Mussolini autore drammatico*, Florence: Barbèra 1954, pp. V–XLIII.
- Frank, Josef: “Der Gschnas fürs G’müt und der Gschnas als Problem,” in: Deutscher Werkbund (ed.): *Bau und Wohnung*, Stuttgart: Wedekind & Co. 1927, pp. 48–57.
- Frank, Josef: “Der Volkswohnungspalast / The People’s Apartment Palace,” trans. Brian Dorsey [German 1926], in: *Schriften. Bd. 1: Veröffentlichte Schriften 1910–1930. Writings. Vol. 1: Published Writings 1910–1930*, ed. Tano Bojankin, Christopher Long, and Iris Meder, Vienna: Metroverlag 2012, pp. 254–267.
- Frank, Josef: “Wiener Bauten und Wohnungen / Viennese Buildings and Apartments,” trans. Kimi Lum [German 1930], in: *Schriften. Bd. 1: Veröffentlichte Schriften 1910–1930. Writings. Vol. 1: Published Writings 1910–1930*, ed. Tano Bojankin, Christopher Long, and Iris Meder, Vienna: Metroverlag 2012, pp. 394–403.
- Funder, Friedrich: *Vom Gestern ins Heute. Aus dem Kaiserreich in die Republik*, 3rd ed., Vienna/Munich: Herold 1971 [1952].
- Gerstenberg, Heinrich: *Deutschland über alles! Vom Sinn und Werden der deutschen Volkshymne*, Munich: Ernst Reinhardt 1933.

- Goebbels, Joseph: "Rede im Kaiserhof am 28.3.1933,"
in: Gerd Albrecht (ed.): *Der Film im Dritten Reich. Eine Dokumentation*, Karlsruhe: Doku Verlag 1979, pp. 26–31.
- Goethe, Johann Wolfgang: *Geschichte Gottfriedens von Berlichingen mit der eisernen Hand dramatisiert. Götz von Berlichingen mit der eisernen Hand. Studienausgabe*, ed. Bodo Plachta, Stuttgart: Hiersemann 2017.
- [Goethe, Johann Wolfgang:] *Götz von Berlichingen mit der eisernen Hand. Ein Schauspiel*, [without place and publisher] 1773.
- Heimatschutz in Österreich*, ed. Propagandastelle der Bundesführung des Österreichischen Heimatschutzes, Vienna: Zoller 1934.
- Hellmuth, G.F.: *Radio-Demokratie! Denkschrift zur Organisation des Strahl-Rundspruches*, Vienna: Rubinstein 1924.
- Herzog, Herta: *Stimme und Persönlichkeit*, University of Vienna: PhD diss. 1932.
- Hoffmann von Fallersleben: "Der deutsche Zollverein," in:
Unpolitische Lieder, Hamburg: Hoffmann und Campe 1840, p. 46.
- Hoffmann von Fallersleben: *Mein Leben. Aufzeichnungen und Erinnerungen. Dritter Band*, Hannover: Carl Rumpeler 1868.
- Hörnigk, Philipp Wilhelm von: *Oesterreich Über alles wann es nur will*, [without place and publisher] 1684.
- Jacques, Norbert: *Das Testament des Dr. Mabuse*, ed. Michael Farin and Günter Scholdt, Hamburg: Rogner & Bernhard 1994.
- Karg-Bebenburg, Arthur: *Weisungen für die Türkenbefreiungs-Gedenkfeier am 14. Mai 1933 in Wien*, Vienna: Österreichischer Heimatschutzverband 1933.
- Kernstock, Ottokar: "Österreichische Volkshymne," in:
Der redende Born, Graz: Leykam 1922, pp. 113–114.
- Kindermann, Heinz: *Das Burgtheater. Erbe und Sendung eines Nationaltheaters*, Vienna: Adolf Luser 1939.
- Krauss, Werner: *Das Schauspiel meines Lebens*, Stuttgart: Henry Goverts 1958.
- Lassalle-Hof. Die Wohnhausanlage der Gemeinde Wien im II. Bezirk*, ed. Wiener Stadtbauamt, Vienna: Reisser [1926].
- Lazarsfeld, Paul F.: "An Episode in the History of Social Research. A Memoir" [1968], in: Patricia L. Kendall (ed.): *The Varied Sociology of Paul F. Lazarsfeld*, New York: Columbia University Press 1982, pp. 11–69.
- Lazarsfeld, Paul: "Zwei Wege der Kommunikationsforschung," in:
Oskar Schatz (ed.): *Die elektronische Revolution. Wie gefährlich sind die Massenmedien?*, Graz: Styria 1975, pp. 197–222.
- Lazarsfeld, Paul F., Bernard Berelson, Hazel Gaudet: *The People's Choice. How the Voter Makes Up His Mind in a Presidential Campaign*, New York: Duell, Sloan and Pearce 1944.
- Lebens-Beschreibung Herrn Gözens von Berlichingen*, ed. Franck von Steigerwald, Nuremberg: Adam Jonathan Felssecker 1731.
- Lippmann, Walter: *Public Opinion*, New York: Harcourt, Brace and Co. 1922.
- Lippmann, Walter: *The Phantom Public*, New York: Harcourt, Brace and Co. 1925.
- Lothar, Rudolph: *Das Wiener Burgtheater. Ein Wahrzeichen österreichischer Kunst und Kultur*, Vienna: Augartenverlag 1934.

- Ludwig, Emil: *Mussolinis Gespräche mit Emil Ludwig*, Berlin: Zsolnay 1932.
- Ludwig, Emil: *Napoleon*, Berlin: Cassirer 1906.
- Ludwig, Emil: *Napoleon*, Berlin: Rowohlt 1925.
- Mechau, Emil: "Das Universal-Tonzusatzgerät," in: Fritz Fischer and Hugo Lichte (eds.): *Tonfilm. Aufnahme und Wiedergabe nach dem Klangfilm-Verfahren (System Klangfilm-Tobis)*, Leipzig: Hirzel 1931, pp. 276–283.
- Mechau, Emil: "Der Wiedergabeprojektor," in: Fritz Fischer and Hugo Lichte (eds.): *Tonfilm. Aufnahme und Wiedergabe nach dem Klangfilm-Verfahren (System Klangfilm-Tobis)*, Leipzig: Hirzel 1931, pp. 271–276.
- Mussolini, Benito and Giovacchino Forzano: *Hundert Tage (Campo di maggio). Drei Akte (acht Bilder). Für die deutsche Bühne bearbeitet von Géza Herczeg*, Berlin: Marton 1932 [Italian 1931].
- Mussolini, Benito and Giovacchino Forzano: *Hundert Tage (Campo di maggio). Drei Akte in neun Bildern. Autorisierte Übersetzung von Géza Herczeg*, Vienna: Zsolnay 1933 [Italian 1931].
- Mussolini, Benito: "The Doctrine of Fascism" [Italian 1932], in: *Fascism. Doctrine and Institutions*, Rome: Ardita 1935, pp. 5–31.
- Neurath, Otto: *International Picture Language. The First Rules of Isotype*, London: Kegan Paul 1936.
- Österreichische Wirtschaftspsychologische Forschungsstelle (ed.): *Die Arbeitslosen von Marienthal. Ein soziographischer Versuch über die Wirkungen langandauernder Arbeitslosigkeit mit einem Anhang zur Geschichte der Soziographie*, Leipzig: Hirzel 1933.
- Pear, Tom Hatherley: *Voice and Personality*, London: Chapman and Hall 1931.
- "Prometheus Filmverleih- und Vertriebs GmbH, Berlin, an Sergej Eisenstein, Moskau, 1. Juni 1926," in: Oksana Bulgakowa (ed.): *Eisenstein und Deutschland. Texte, Dokumente, Briefe*, Berlin: Akademie der Künste 1998, pp. 75–78.
- Röbbling, Hermann: *Das Theater als völkerverbindender Faktor*, Vienna: Weiner 1932.
- Röbbling, Hermann: "Stimmen der Völker im Drama," in: *Almanach der österreichischen Bundestheater für das Spieljahr 1932/33*, Vienna: Wirtschafts-Zeitungs-Verlags-Ges.m.b.H. 1933, pp. 22–24.
- Schwaiger, Gustav: "Die bisherige Entwicklung der technischen Einrichtungen der 'Ravag,'" in: *Fünf Jahre Österreichischer Rundfunk*, Vienna: RAVAG 1929, pp. 51–71.
- Starhemberg, Ernst Rudiger: *Between Hitler and Mussolini*, New York/London: Harper & Brothers 1942.
- Starhemberg, Ernst Rüdiger: *Die Erinnerungen*, Vienna/Munich: Amalthea 1991.
- Starhemberg, Ernst Rüdiger: *Die Reden des Vizekanzlers E.R. Starhemberg*, Vienna: Österreichischer Bundespressedienst 1935.
- Starhemberg, Ernst Rüdiger: *Österreichs Weg*, Vienna: Österreichischer Heimatschutz 1934.
- Tischner, Horst: "Das Reiss-Mikrophon," in: Fritz Fischer and Hugo Lichte (eds.): *Tonfilm. Aufnahme und Wiedergabe nach dem Klangfilm-Verfahren (System Klangfilm-Tobis)*, Leipzig: Hirzel 1931, pp. 170–171.

Trendelenburg, Ferdinand: "Der Blatthaller," in: Fritz Fischer and Hugo Lichte (eds.): *Tonfilm. Aufnahme und Wiedergabe nach dem Klangfilm-Verfahren (System Klangfilm-Tobis)*, Leipzig: Hirzel 1931, pp. 171–174. *Wiener Adressbuch. Lehmanns Wohnungsanzeiger 1933*, vol. 1, Vienna: Österreichische Anzeigen-Gesellschaft 1933.

Secondary Literature

- Achenbach, Michael and Karin Moser: "Filmografie – Österreich in Bild und Ton," in: Michael Achenbach and Karin Moser (eds.): *Österreich in Bild und Ton. Die Filmwochenschau des austrofaschistischen Ständestaates*, Vienna: Filmarchiv Austria 2002, pp. 397–556.
- Achleitner, Friedrich: "Bauten von Wagner-Schülern in der Zwischenkriegszeit" [1987], in: *Wiener Architektur. Zwischen typologischem Fatalismus und semantischem Schlamassel*, Vienna: Böhlau 1996, pp. 44–51.
- Achleitner, Friedrich: "Der Wiener Gemeindebau als Teil einer sozialreformerischen Konzeption. Historische, politische und wirtschaftliche Vorbedingungen" [1983], in: *Wiener Architektur. Zwischen typologischem Fatalismus und semantischem Schlamassel*, Vienna: Böhlau 1996, pp. 73–80.
- Achleitner, Friedrich: *Österreichische Architektur im 20. Jahrhundert. Ein Führer in vier Bänden. Vol. III/1: Wien, 1.–12. Bezirk*, St. Pölten: Residenz 1990.
- Achleitner, Friedrich: "Wiener Architektur der Zwischenkriegszeit. Kontinuität, Irritation und Resignation" [1981], in: *Wiener Architektur. Zwischen typologischem Fatalismus und semantischem Schlamassel*, Vienna: Böhlau 1996, pp. 52–72.
- Ash, Mitchell G.: "Die Entwicklung des Wiener Psychologischen Instituts 1922–1938," in: Achim Eschbach (ed.): *Karl Bühler's Theory of Language*, Amsterdam: Benjamins 1988, pp. 303–325.
- Aurich, Rolf, Wolfgang Jacobson, Cornelius Schnauber (eds.): *Fritz Lang. Leben und Werk. Bilder und Dokumente*, Berlin: jovis 2001.
- Bächtold-Stäubli, Hanns: "Hinterer," in: Eduard Hoffmann-Krayer and Hanns Bächtold-Stäubli (eds.): *Handwörterbuch des deutschen Aberglaubens*, vol. IV, Berlin/Leipzig: Walter de Gruyter 1932, pp. 61–68.
- Bakhtin, Mikhail M.: "Forms of Time and of the Chronotope in the Novel" [Russian 1975], in: *The Dialogic Imagination. Four Essays*, ed. Michael Holquist, trans. Caryl Emerson and Michael Holquist, Austin: University of Texas Press 1981, pp. 84–258.
- Bakhtin, Mikhail: *Rabelais and His World*, trans. Helene Iswolsky, Bloomington: Indiana University Press 1984 [Russian 1965].
- Bauer, Kurt: *Hitlers zweiter Putsch. Dollfuß, die Nazis und der 25. Juli 1934*, St. Pölten: Residenz 2014.
- Bauer, Lilli and Werner T. Bauer: "Der Karl-Marx-Hof. 'Schaut! –, das ist ein Stück Marxismus!,'" in: Werner Michael Schwarz, Georg Spitaler, Elke Wikidal (eds.): *Das Rote Wien. 1919–1934*, Basel: Birkhäuser 2019, pp. 199–203.
- Beckermann, Ruth (ed.): *Die Mazzesinsel. Juden in der Wiener Leopoldstadt 1918–1938*, Vienna: Löcker 1984.

- Benjamin, Walter: "The Work of Art in the Age of Its Technological Reproducibility," trans. Harry Zohn and Edmund Jephcott [German 1936/39], in: *Selected Writings. Vol. 4: 1938–1940*, ed. Michael W. Jennings, Cambridge: Harvard University Press 2006, pp. 251–283.
- Bernard, Andreas: *The Triumph of Profiling. The Self in Digital Culture*, trans. Valentine A. Pakis, Cambridge: Polity 2019 [German 2017].
- Bernhart, Toni: "Benito Mussolini als Schriftsteller und seine Übersetzungen ins Deutsche," in: Andrea Albrecht, Lutz Danneberg, Simone De Angelis (eds.): *Die akademische "Achse Rom-Berlin"? Der wissenschaftlich-kulturelle Austausch zwischen Italien und Deutschland 1920 bis 1945*, Berlin: Walter de Gruyter 2017, pp. 345–399.
- Besslich, Barbara: *Der deutsche Napoleon-Mythos. Literatur und Erinnerung 1800–1945*, Darmstadt: WBG 2007.
- Blau, Eve: *The Architecture of Red Vienna 1919–1934*, Cambridge: MIT Press 1999.
- Blau, Eve: "Wien 1919–1934. Grossstadt und Proletariat im 'Roten Wien,'" in: Eve Blau and Monika Platzer (eds.): *Mythos Grossstadt. Architektur und Stadtbaukunst in Zentraleuropa 1890–1937*, Munich: Prestel 1999, pp. 205–214.
- Blume, Herbert: "Maas, Memel, Etsch und Belt. Die Gewässer in Hoffmanns *Lied der Deutschen* und die Grenzen des 'Vaterlands,'" in: Marek Hałub and Kurt Schuster (eds.): *Hoffmann von Fallersleben. Internationales Symposium Wrocław/Breslau 2003*, Bielefeld: Verlag für Regionalgeschichte 2005, pp. 247–265.
- Bruss, Susanne: "Neue Küchen für Neue Frauen. Modernisierung der Hauswirtschaft im Roten Wien," in: Werner Michael Schwarz, Georg Spitaler, Elke Wikidal (eds.): *Das Rote Wien. 1919–1934*, Basel: Birkhäuser 2019, pp. 242–245.
- Brocza, Judith and Christian Stadelmann: *Die Leute von Schönbrunn. Über die Nutzung des Schlosses im 20. Jahrhundert*, Vienna: Schloss Schönbrunn 2000.
- Bulgakowa, Oksana: "Montagebilder bei Sergej Eisenstein," in: Hans Beller (ed.): *Handbuch der Montage*, 4th ed., Munich: TR-Verlagsunion 2002, pp. 49–77.
- Burdick, Anne, Johanna Drucker, Peter Lunenfeld, Todd Presner, Jeffrey Schnapp: *Digital Humanities*, Cambridge: MIT Press 2012.
- Burke, Christopher, Eric Kindel, Sue Walker (eds.): *Isotype. Design and Contexts. 1925–1971*, London: Hyphen Press 2013.
- Chion, Michel: *La voix au cinéma*, Paris: Editions de l'Etoile 1993 [1982].
- Crafton, Donald: *The Talkies. American Cinema's Transition to Sound, 1926–1931*, New York: Charles Scribner's Sons 1997.
- Crary, Jonathan: "Dr. Mabuse and Mr. Edison," in: Russell Ferguson (ed.): *Art and Film Since 1945. Hall of Mirrors*, New York: Monacelli 1996, pp. 262–279.
- Danimann, Franz: "Der 11. März 1938 in Wien," in: Franz Danimann (ed.): *Finis Austriae. Österreich, März 1938*, Vienna: Europaverlag 1978, pp. 55–71.
- Decker, Kerstin: *Die Schwester. Das Leben der Elisabeth Förster-Nietzsche*, Berlin: Berlin Verlag 2016.

- Deleuze, Gilles: "Bartleby; or, The Formula" [French 1989], in: *Essays Critical and Clinical*, trans. Daniel W. Smith and Michael A. Greco, Minneapolis: University of Minnesota Press 1997 [French 1993], pp. 68–90.
- Deleuze, Gilles: "What is a *dispositif*?" in: Timothy J. Armstrong (ed.): *Michel Foucault Philosopher*, trans. Timothy J. Armstrong, New York: Routledge 1992 [French 1989], pp. 159–168.
- Dietrich, Margret: "Burgtheaterpublikum und Öffentlichkeit in der Ersten Republik," in: Margret Dietrich (ed.): *Das Burgtheater und sein Publikum*, vol. I, Vienna: Österreichische Akademie der Wissenschaften 1976, pp. 479–707.
- Drucker, Johanna: *Graphesis. Visual Forms of Knowledge Production*, Cambridge: Harvard University Press 2014.
- Duchkowitsch, Wolfgang: "Umgang mit 'Schädlingen' und 'schädlichen Auswüchsen.' Zur Auslöschung der freien Medienstruktur im 'Ständestaat,'" in: Emmerich Tálos and Wolfgang Neugebauer (eds.): *Austrofaschismus. Politik – Ökonomie – Kultur. 1933–1938*, 5th ed., Vienna: LIT 2005, pp. 358–370.
- Ehlert, Ralf Gerhard: "Public-Address-Strategien von 1919 bis 1949," in: Daniel Gethmann and Markus Stauff (eds.): *Politiken der Medien*, Zurich/Berlin: diaphanes 2005, pp. 319–340.
- Elliott, John H.: *Beware the Evil Eye. The Evil Eye in the Bible and the Ancient World. Vol. 2: Greece and Rome*, Cambridge: James Clarke 2016.
- Epping-Jäger, Cornelia: "'Eine einzige jubelnde Stimme.' Zur Etablierung des Dispositivs Laut/Sprecher in der politischen Kommunikation des Nationalsozialismus," in: Cornelia Epping-Jäger and Erika Linz (eds.): *Medien/Stimmen*, Cologne: DuMont 2003, pp. 100–123.
- Ergert, Viktor: *50 Jahre Rundfunk in Österreich. Vol. I: 1924–1945*, Vienna: Residenz 1974.
- Ewen, Stuart: *PR! A Social History of Spin*, New York: Basic Books 1996.
- Feichtinger, Johannes and Johann Heiss (eds.): *Geschichtspolitik und "Türkenbelagerung"*, Vienna: Mandelbaum 2013.
- Fleck, Christian and Nico Stehr: "Einleitung. Von Wien nach New York," in: Paul F. Lazarsfeld: *Empirische Analyse des Handelns. Ausgewählte Schriften*, trans. Hella Beister, ed. Christian Fleck and Nico Stehr, Frankfurt a.M.: Suhrkamp 2007, pp. 7–58.
- Fleck, Christian: *Rund um "Morienthal." Von den Anfängen der Soziologie in Österreich bis zu ihrer Vertreibung*, Vienna: Verlag für Gesellschaftskritik 1990.
- Foucault, Michel: *Discipline and Punish. The Birth of the Prison*, trans. Alan Sheridan, New York: Vintage Books 1995 [French 1975].
- Foucault, Michel: "Foucault," trans. Robert Hurley [French 1984], in: *Essential Works of Foucault. 1954–1984*, vol. 2, ed. James Faubion, Harmondsworth: Penguin 2000, pp. 459–463.
- Foucault, Michel: *Security, Territory, Population. Lectures at the Collège de France 1977–1978*, trans. Graham Burchell, ed. Michel Senellart, Basingstoke: Palgrave Macmillan 2007 [French 2004].

- Foucault, Michel: "The Confession of the Flesh," trans. Colin Gordon [French 1977], in: *Power/Knowledge. Selected Interviews and Other Writings 1972–1977*, ed. Colin Gordon, New York: Pantheon 1980, pp. 194–228.
- Foucault, Michel: *The Order of Things. An Archaeology of the Human Sciences*, London/New York: Routledge 2002 [French 1966].
- Foucault, Michel: "What is Critique?," trans. Lysa Hochroth [French 1978], in: *The Politics of Truth*, ed. Sylvère Lotringer, Los Angeles: Semiotext(e) 2007, pp. 1–81.
- Frank, Horst Joachim: *Handbuch der deutschen Strophenformen*, Tübingen: Francke 1993.
- Freud, Sigmund: "Character and Anal Erotism" [German 1908], in: *The Standard Edition of the Complete Psychological Works of Sigmund Freud. Vol. IX: 1906–1908*, ed. and trans. James Strachey, London: Hogarth Press 1959, pp. 167–176.
- Fritz, Walter: *Kino in Österreich. 1929–1945*, Vienna: ÖBV 1991.
- Galloway, Alexander R.: *The Interface Effect*, Cambridge: Polity 2012.
- Ganahl, Simon: *Karl Kraus und Peter Altenberg. Eine Typologie moderner Haltungen*, Konstanz: Konstanz University Press 2015.
- Gentner, Carin: "Zur Geschichte des Leitartikels," in: Winfried B. Lerg, Michael Schmolke, Gerhard E. Stoll (eds.): *Publizistik im Dialog*, Assen: van Gorcum 1965, pp. 60–68.
- Gloger, Josef: "Die österreichische Selenophon Licht- und Tonbildges. m.b.H.," in: Michael Achenbach and Karin Moser (eds.): *Österreich in Bild und Ton. Die Filmwochenschau des austrofaschistischen Ständestaates*, Vienna: Filmarchiv Austria 2002, pp. 149–160.
- Grabher, Peter: "Sowjet-Projektionen. Die Filmarbeit der kommunistischen Organisationen in der Ersten Republik (1918–1933)," in: Christian Dewald (ed.): *Arbeiterkino. Linke Filmkultur der Ersten Republik*, Vienna: Filmarchiv Austria 2007, pp. 221–303.
- Grasberger, Franz: *Die Hymnen Österreichs*, Tutzing: Hans Schneider 1968.
- Gruber, Helmut: *Red Vienna. Experiment in Working-Class Culture 1919–1934*, New York/Oxford: Oxford University Press 1991.
- Gunning, Tom: *The Films of Fritz Lang. Allegories of Vision and Modernity*, London: BFI 2000.
- Hajós, Beatrix: *Die Schönbrunner Schlossgärten. Eine topographische Kulturgeschichte*, Vienna: Böhlau 1995.
- Hassmann, Elisabeth: *Von Katterburg zu Schönbrunn. Die Geschichte Schönbrunn bis Kaiser Leopold I.*, Vienna: Böhlau 2004.
- Hautmann, Hans and Rudolf Hautmann: *Die Gemeindebauten des Roten Wien 1919–1934*, Vienna: Schönbrunn-Verlag 1980.
- Heiss, Johann and Johannes Feichtinger (eds.): *Der erinnerte Feind*, Vienna: Mandelbaum 2013.
- Henkel, Gabriele: "'Wie freu ich mich der hellen Tage!' Ergänzende Anmerkungen zum Thema 'Hoffmann und die Romantik,'" in: Bettina Greffrath, Gabriele Henkel, Christin Langermann (eds.): *Hoffmann von Fallersleben. Dichter, Germanist und singender Freiheitskämpfer*, Hildesheim: Olms 2015, pp. 36–43.

- Höbelt, Lothar: *Die Heimwehren und die österreichische Politik 1927–1936. Vom politischen "Kettenhund" zum "Austro-Fascismus"?*, Graz: Ares 2016.
- Hounshell, Eric Tapken: *A Feel for the Data. Paul F. Lazarsfeld and the Columbia University Bureau of Applied Social Research*, University of California, Los Angeles: PhD diss. 2017.
- Hunecke, Volker: *Napoleons Rückkehr. Die letzten Hundert Tage – Elba, Waterloo, St. Helena*, Stuttgart: Klett-Cotta 2015.
- Hüttner, Johann: "Die Staatstheater in den dreissiger Jahren. Kunst als Politik – Politik in der Kunst," in: Hilde Haider-Pregler and Beate Reiterer (eds.): *Verspielte Zeit. Österreichisches Theater der dreissiger Jahre*, Vienna: Picus 1997, pp. 60–76.
- Jahn, Otto: "Über den Aberglauben des bösen Blicks bei den Alten," in: *Berichte über die Verhandlungen der Königlich Sächsischen Gesellschaft der Wissenschaften zu Leipzig. Philologisch-Historische Classe. Siebenter Band*, Leipzig: Hirzel 1855, pp. 28–110.
- Jahoda, Marie: "Paul Felix Lazarsfeld in Vienna," in: Jacques Lautman and Bernard-Pierre Lécuyer (eds.): *Paul Lazarsfeld (1901–1976). La sociologie de Vienne à New York*, Paris: L'Harmattan 1998, pp. 135–140
- Jedlicka, Ludwig: "Ernst Rüdiger Starhemberg und die politische Entwicklung in Österreich im Frühjahr 1938," in: *Vom alten zum neuen Österreich. Fallstudien zur österreichischen Zeitgeschichte 1900–1975*, St. Pölten: Niederösterreichisches Pressehaus 1977, pp. 289–310.
- Jellinek, Georg: *Allgemeine Staatslehre*, 3rd ed., Berlin: Häring 1914 [1900].
- Jeřábek, Hynek: *Paul Lazarsfeld's Research Methodology. Biography, Methods, Famous Projects*, Prague: Karolinum Press 2006.
- Jerouschek, Günter: "Er aber, sagt ihm, er kann mich im Arsch lecken." *Psychoanalytische Überlegungen zu einer Beschämungsformel und ihrer Geschichte*, Giessen: Psychozial-Verlag 2005.
- Jossé, Harald: *Die Entstehung des Tonfilms. Beitrag zu einer faktenorientierten Mediengeschichtsschreibung*, Freiburg/Munich: Karl Alber 1984.
- Karner, Herbert: "Vom Jagdschloss zur Sommerresidenz. Die Baugeschichte des Schlosses von seinen Anfängen bis 1918," in: Franz Sattler (ed.): *Schönbrunn*, Baden: Edition Lammerhuber 2017, pp. 136–163.
- Kim, Annette Miae: *Sidewalk City. Remapping Public Space in Ho Chi Minh City*, Chicago: University of Chicago Press 2015.
- Klaus, Elisabeth and Josef Seethaler (eds.): *What Do We Really Know About Herta Herzog? Exploring the Life and Work of a Pioneer of Communication Research*, Frankfurt a.M.: Peter Lang 2016.
- Koopman, Colin: *How We Became Our Data. A Genealogy of the Informational Person*, Chicago/London: University of Chicago Press 2019.
- Kreimeier, Klaus: *Die Ufa-Story. Geschichte eines Filmkonzerns*, Munich/Vienna: Hanser 1992.
- Kristan, Markus: *Hubert Gessner. Architekt zwischen Kaiserreich und Sozialdemokratie 1871–1943*, ed. Gabriela Gantenbein, Vienna: Passagen 2011.
- Kröll, Katrin: "Der schalkhaft beredsame Leib als Medium verborgener Wahrheit. Zur Bedeutung von 'Entblössungsgebärden' in mittelalterlicher Bildkunst, Literatur und darstellendem Spiel,"

- in: Katrin Kröll and Hugo Steger (eds.): *Mein ganzer Körper ist Gesicht. Grotteske Darstellungen in der europäischen Kunst und Literatur des Mittelalters*, Freiburg: Rombach 1994, pp. 239–294.
- Kucher, Primus-Heinz: “Radiokultur und Radioästhetik in Österreich 1924–1934,” in: Primus-Heinz Kucher and Rebecca Unterberger: *“Akustisches Drama.” Radioästhetik, Kultur und Radiopolitik in Österreich 1924–1934*, Bielefeld: Aisthesis 2013, pp. 11–39.
- Kurdiovsky, Richard: *Die Gärten von Schönbrunn. Ein Spaziergang durch einen der bedeutendsten Barockgärten Europas*, St. Pölten: Residenz 2005.
- Latour, Bruno: *Reassembling the Social. An Introduction to Actor-Network-Theory*, New York/Oxford: Oxford University Press 2005.
- Law, Alma and Mel Gordon: *Meyerhold, Eisenstein and Biomechanics. Actor Training in Revolutionary Russia*, Jefferson/London: McFarland 1996.
- Leibnitz, Thomas: “‘Gott! erhalte...’ Joseph Haydns Kaiserlied und die Hymnen Österreichs,” in: Thomas Leibnitz (ed.): *Joseph Haydn. Gott erhalte. Schicksal einer Hymne*, Vienna: Österreichische Nationalbibliothek 2008, pp. 8–69.
- Lockner, Armin: “Privater Staatsbetrieb. Anmerkungen zu einer Entwicklungsgeschichte der Selenophon,” in: Hrvoje Miloslavac (ed.): *Die Ostmark-Wochenschau. Ein Propagandamedium des Nationalsozialismus*, Vienna: Filmarchiv Austria 2008, pp. 46–69.
- Lorenz, Hellmut: *Johann Bernhard Fischer von Erlach*, Zurich: Verlag für Architektur 1992.
- Mark, Desmond (ed.): *Paul Lazarsfelds Wiener RAVAG-Studie 1932. Der Beginn der modernen Rundfunkforschung*, Vienna: Guthmann-Peterson 1996.
- Mattern, Shannon: *Code + Clay... Data + Dirt. Five Thousand Years of Urban Media*, Minneapolis: University of Minnesota Press 2017.
- Mattern, Shannon: *Deep Mapping the Media City*, Minneapolis: University of Minnesota Press 2015.
- McFarland, Rob, Georg Spitaler, Ingo Zechner (eds.): *The Red Vienna Sourcebook*, Rochester: Camden House 2020.
- Mühl-Benninghaus, Wolfgang: “Vom Stummfilm zum Tonfilm,” in: Joachim-Felix Leonhard et al. (eds.): *Medienwissenschaft. Ein Handbuch zur Entwicklung der Medien und Kommunikationsformen*, vol. 2, Berlin/New York: Walter de Gruyter 2001, pp. 1027–1032.
- Mühlen, Bernt Ture von zur: *Hoffmann von Fallersleben. Biographie*, Göttingen: Wallstein 2010.
- Nance, Susan: “Elephants and the American Circus,” in: Susan Weber, Kenneth L. Ames, Matthew Wittmann (eds.): *The American Circus*, New Haven/London: Yale University Press 2012, pp. 232–249, here pp. 238–239.
- Neurath, Paul: “Die methodische Bedeutung der RAVAG-Studie von Paul F. Lazarsfeld,” in: Desmond Mark (ed.): *Paul Lazarsfelds Wiener RAVAG-Studie 1932. Der Beginn der modernen Rundfunkforschung*, Vienna: Guthmann-Peterson 1996, pp. 11–26.
- Orosz, Eva-Maria: “Wohnen lernen,” in: Werner Michael Schwarz, Georg Spitaler, Elke Wikidal (eds.): *Das Rote Wien. 1919–1934*, Basel: Birkhäuser 2019, pp. 246–253.
- Pensold, Wolfgang: *Zur Geschichte des Rundfunks in Österreich. Programm für die Nation*, Wiesbaden: Springer 2018.

- Peucker, Brigitte: "Fritz Lang. Object and Thing in the German Films," in: Joe McElhaney (ed.): *A Companion to Fritz Lang*, Chichester: Wiley & Sons 2015, pp. 279–299.
- Pfarrhofer, Hedwig: *Friedrich Funder. Ein Mann zwischen Gestern und Morgen*, Graz: Styria 1978.
- Pilz, Katrin: "Mutter (Rotes) Wien. Fürsorgepolitik als Erziehungs- und Kontrollinstanz im 'Neuen Wien,'" in: Werner Michael Schwarz, Georg Spitaler, Elke Wikidal (eds.): *Das Rote Wien. 1919–1934*, Basel: Birkhäuser 2019, pp. 74–81.
- Pirhofer, Gottfried and Reinhard Sieder: "Zur Konstitution der Arbeiterfamilie im Roten Wien. Familienpolitik, Kulturreform, Alltag und Ästhetik," in: Michael Mitterauer and Reinhard Sieder (eds.): *Historische Familienforschung*, Frankfurt a.M.: Suhrkamp 1982, pp. 326–368.
- Presner, Todd, David Shepard, Yoh Kawano: *HyperCities. Thick Mapping in the Digital Humanities*, Cambridge: Harvard University Press 2014.
- Price, Munro: *Napoleon. The End of Glory*, New York/Oxford: Oxford University Press 2014.
- Pyräh, Robert: *The Burgtheater and Austrian Identity. Theatre and Cultural Politics in Vienna, 1918–38*, London: Legenda 2007.
- Raimondo-Souto, Héctor Mario: *Motion Picture Photography. A History 1891–1960*, Jefferson: McFarland 2006.
- Robinson, Jack Fay: *Bell & Howell Company. A 75-Year History*, Chicago: Bell & Howell 1982.
- Rothländer, Christiane: "Das 'Adolf-Hitler-Haus' in der Hirschengasse 25, Mariahilf," in: Kilian Franer and Ulli Fuchs (eds.): *Erinnern für die Zukunft. Ein Projekt zum Gedächtnis an die Mariahilfer Opfer des NS-Terrors*, Vienna: Echomedia 2009, pp. 147–150.
- Rudolph, Harriet: "Die visuelle Kultur des Reiches. Kaiserliche Einzüge im Medium der Druckgraphik," in: Heinz Schilling, Werner Heun, Jutta Götzmann (eds.): *Heiliges Römisches Reich Deutscher Nation 962–1806. Altes Reich und neue Staaten 1495–1806*, vol. 2: Essays, Dresden: Sandstein 2006, pp. 231–241.
- Samuel, Lawrence R.: *Freud on Madison Avenue. Motivation Research and Subliminal Advertising in America*, Philadelphia/Oxford: University of Pennsylvania Press 2010.
- Scheffler, Wolfgang: "Massenmord in Kowno," in: Wolfgang Scheffler and Diana Schulle (eds.): *Buch der Erinnerung. Die ins Baltikum deportierten deutschen, österreichischen und tschechoslowakischen Juden*, vol. 1, Munich: Saur 2003, pp. 83–188.
- Schellenberg, Kathrin: "Das Lied der Deutschen – Geschichte und Rezeption," in: Bettina Greffrath, Gabriele Henkel, Christin Langermann (eds.): *Hoffmann von Fallersleben. Dichter, Germanist und singender Freiheitskämpfer*, Hildesheim: Olms 2015, pp. 215–233.
- Schieder, Wolfgang: *Faschistische Diktaturen. Studien zu Italien und Deutschland*, Göttingen: Wallstein 2008.
- Schlabrendorf, Gustav von: *Anti-Napoleon*, Frankfurt a.M.: Eichborn 1991 [1804].
- Schlögl, Reinhard: *Oskar Czeija. Radio- und Fernsehponier, Unternehmer, Abenteurer*, Vienna: Böhlau 2005.

- Schumacher, Olaf and Hans Jürgen Wulff: "Warner, Fox, Tobis-Klangfilm und die Anfänge des Tonfilms," in: Joachim-Felix Leonhard et al. (eds.): *Medienwissenschaft. Ein Handbuch zur Entwicklung der Medien und Kommunikationsformen*, vol. 2, Berlin/New York: Walter de Gruyter 2001, pp. 1198–1207.
- Schütz, Karl: *Theater- und Kinoorgeln in Wien*, Vienna: Österreichische Akademie der Wissenschaften 1991.
- Schwarzkopf, Stefan and Rainer Gries (eds.): *Ernest Dichter and Motivation Research. New Perspectives on the Making of Post-War Consumer Culture*, New York: Palgrave Macmillan 2010.
- Schwarz, Werner Michael: *Kino und Kinos in Wien. Eine Entwicklungsgeschichte bis 1934*, Vienna: Turia + Kant 1992.
- Schwerdling, Johann: *Geschichte des Hauses Starhemberg*, Linz: Feichtinger 1830.
- Sedlmayr, Hans: *Johann Bernhard Fischer von Erlach*, Stuttgart: DVA 1997 [1976].
- Siebmacher's Wappenbuch*, vol. 27: *Die Wappen des Adels in Oberösterreich*, Neustadt an der Aisch: Bauer und Raspe 1984 [1904].
- Sieder, Reinhard J.: "Wohnen und Haushalten im Gemeindebau. Politischer Diskurs, Repräsentation, Praxis, kulturelle Folgen," in: Werner Michael Schwarz, Georg Spitaler, Elke Wikidal (eds.): *Das Rote Wien. 1919–1934*, Basel: Birkhäuser 2019, pp. 234–241.
- Sommer-Mathis, Andrea: "...*ma il Papa rispose, che il Re de' Romani a Roma era lui.*" Frühneuzeitliche Krönungsfestlichkeiten am Kaiser- und Papsthof," in: Richard Bösel, Grete Klingenstein, Alexander Koller (eds.): *Kaiserhof – Papsthof. 16.–18. Jahrhundert*, Vienna: Österreichische Akademie der Wissenschaften 2006, pp. 251–284.
- Sommer-Mathis, Andrea: "Theater und Fest," in: Hellmut Lorenz and Anna Mader-Kratky (eds.): *Die Wiener Hofburg 1705–1835. Die kaiserliche Residenz vom Barock bis zum Klassizismus*, Vienna: Österreichische Akademie der Wissenschaften 2016, pp. 457–486.
- Staats- und Verfassungskrise 1933*, ed. österreichische Parlamentsdirektion, Vienna: Böhlau 2014.
- Stachel, Peter: *Mythos Heldenplatz. Hauptplatz und Schauplatz der Republik*, Vienna: Molden 2018.
- Statistisches Jahrbuch Österreichs 2018*, Vienna: Verlag Österreich 2018.
- Steinbauer, Johannes: *Land der Hymnen. Eine Geschichte der Bundeshymnen Österreichs*, Vienna: Sonderzahl 1997.
- Stein, Hans-Peter: *Symbole und Zeremoniell in deutschen Streitkräften vom 18. bis zum 20. Jahrhundert*, Herford/Bonn: Mittler 1984.
- Stieg, Gerald: *Sein oder Schein. Die Österreich-Idee von Maria Theresia bis zum Anschluss*, Vienna: Böhlau 2016.
- Stiegler, Bernd: *Der montierte Mensch. Eine Figur der Moderne*, Paderborn: Fink 2016.
- Tálos, Emmerich: "Das austrofaschistische Herrschaftssystem," in: Emmerich Tálos and Wolfgang Neugebauer (eds.): *Austrofaschismus. Politik – Ökonomie – Kultur. 1933–1938*, 5th ed., Vienna: LIT 2005, pp. 394–420.
- Teuber, Oscar: *Die österreichische Armee von 1700 bis 1867*, vol. 1, Vienna: Berté & Czeiger 1895.

- Thompson, Kristin: "Initial Standardization of the Basic Technology," in: David Bordwell, Janet Staiger, Kristin Thompson (eds.): *The Classical Hollywood Cinema. Film Style and Mode of Production to 1960*, London: Routledge 2006 [1985], pp. 262–280.
- Transfeldt, Walter: *Wort und Brauch in Heer und Flotte*, 9th ed., Stuttgart: Spemann 1986.
- Tye, Larry: *The Father of Spin. Edward L. Bernays and the Birth of Public Relations*, New York: Crown 1998.
- Ulmschneider, Helgard: *Götz von Berlichingen. Ein adeliges Leben der deutschen Renaissance*, Sigmaringen: Thorbecke 1974.
- Venus, Theodor: "Vom Funk zum Rundfunk – Ein Kulturfaktor entsteht," in: Isabella Ackerl and Rudolf Neck (eds.): *Geistiges Leben im Österreich der Ersten Republik*, Vienna: Verlag für Geschichte und Politik 1986, pp. 379–415.
- Vocelka, Karl: "Die Herrschaft der Habsburger. Wie ein Schloss zum Symbol der Dynastie wurde," in: Franz Sattler (ed.): *Schönbrunn*, Baden: Edition Lammerhuber 2017, pp. 98–129.
- Vogel, Jakob: *Nationen im Gleichschritt. Der Kult der 'Nation in Waffen' in Deutschland und Frankreich, 1871–1914*, Göttingen: Vandenhoeck & Ruprecht 1997.
- Wacks, Georg: "Der schöne Moritz von der Klabriaspertie. Die Budapester Orpheum Gesellschaft. Eine Ausnahmerecheinung der Wiener Unterhaltungskultur," in: Marie-Theres Arnbom and Georg Wacks (eds.): *Jüdisches Kabarett in Wien. 1889–2009*, Vienna: Armin Berg 2009, pp. 53–62.
- Wacks, Georg: *Die Budapester Orpheumgesellschaft. Ein Variété in Wien 1889–1919*, Vienna: Holzhausen 2002.
- Walterskirchen, Gudula: *Starhemberg oder Die Spuren der "30er Jahre"*, Vienna: Amalthea 2002.
- Wedel, Michael: "Klärungsprozesse. Tobis, Klangfilm und die Tonfilmumstellung 1928–32," in: Jan Distelmeyer (ed.): *Tonfilmfrieden/ Tonfilmkrieg. Die Geschichte der Tobis vom Technik-Syndikat zum Staatskonzern*, Munich: edition text + kritik 2003, pp. 34–43.
- Weihsmann, Helmut: *Das Rote Wien. Sozialdemokratische Architektur und Kommunalpolitik 1919–1934*, 2nd ed., Vienna: Promedia 2002.
- Wiltschegg, Walter: *Die Heimwehr. Eine unwiderstehliche Volksbewegung?*, Vienna: Verlag für Geschichte und Politik 1985.
- Wimberly, Cory: *How Propaganda Became Public Relations. Foucault and the Corporate Government of the Public*, New York: Routledge 2020.
- Wöhrle, Dieter: *Bertolt Brechts medienästhetische Versuche*, Cologne: Prometh 1988.
- Wolczko, Tekla Kulczicky de: *Hermann Röbbling und das Burgtheater*, University of Vienna: PhD diss. 1950.
- Zeisel, Hans: "Die Wiener Schule der Motivforschung" [1967], in: Josef Langer (ed.): *Geschichte der österreichischen Soziologie. Konstituierung, Entwicklung und europäische Bezüge*, Vienna: Verlag für Gesellschaftskritik 1988, pp. 157–166.

Zuber, Barbara: *Die "Polizeijahresschauen" 1928–1938. Eine filmische Quelle zur Wiener Polizeigeschichte der Zwischenkriegszeit*, University of Vienna: PhD diss. 1996.

2.3 Journals and Newspapers

Primary Literature

- "1. Telegraphenverordnung," in: *Bundesgesetzblatt für die Republik Österreich* (BGBl.), 77/346 (September 27, 1924), pp. 1233–1239.
- "530 Personen festgenommen," in: *Wiener Zeitung* (Vienna), May 16, 1933, p. 4.
- "Abreise der deutschen Funktionäre,"
in: *Neue Freie Presse* (Vienna), May 15, 1933 (evening edition), p. 4.
- Adler, Robert: "Die Geheimsprache der Amateursender,"
in: *Rundfunk für alle* (Vienna), 2/4 (January 22, 1933), p. 12.
- "Alles für Österreich," in: *Reichspost* (Vienna), April 19, 1933, p. 2.
- "An Grossartigkeit alles übertroffen,"
in: *Wiener Mittagsblatt* (Vienna), May 15, 1933, p. 3.
- "A Song for Two Voices. As Sung at Both Playhouses,"
in: *The Gentleman's Magazine* (London), 15 (1745), p. 552.
- Auernheimer, Raoul: "Mussolinis Napoleon,"
in: *Neue Freie Presse* (Vienna), April 23, 1933 (morning edition), pp. 1–3.
- "Aufbruch!," in: *Reichspost* (Vienna), March 3, 1933, p. 1.
- "Aus der nationalsozialistischen Freiheitsbewegung,"
in: *Deutschoesterreichische Tages-Zeitung* (Vienna), May 13, 1933, p. 7.
- "Aus der Radiowoche," in: *Arbeiter-Zeitung* (Vienna), April 3, 1933, p. 5.
- "Ausnahmen vom Aufmarschverbot statthaft,"
in: *Reichspost* (Vienna), May 14, 1933, p. 1.
- Bach, David Josef: "Das Ende einer Diktatur,"
in: *Arbeiter-Zeitung* (Vienna), April 23, 1933, p. 7.
- [Bauer, Otto:] "Austromarxismus,"
in: *Arbeiter-Zeitung* (Vienna), November 3, 1927, pp. 1–2.
- "Begeisterungstürme begrüßen Hitlers Minister,"
in: *Deutschoesterreichische Tages-Zeitung* (Vienna), May 14, 1933, p. 1.
- Bell, Donald J.: "A Letter from Donald Bell," in: *International Photographer* (Hollywood), 2/1 (February 1930), pp. 18–21.
- Bernays, Edward L.: "Manipulating Public Opinion. The Why and the How,"
in: *American Journal of Sociology*, 33/6 (1928), pp. 958–971.
- Blauner, Jacob: "Wer hört alles Rundfunk? Berufsstatistik der deutschen Hörschaft," in: *Radiowelt* (Vienna), 8/46 (November 14, 1931), pp. 1477–1478.
- Brecka, Hans: "Hundert Tage," in: *Reichspost* (Vienna), April 23, 1933, pp. 2–3.
- "Bürgerliche 'Demokraten,'" in: *Arbeiter-Zeitung* (Vienna), May 16, 1933, p. 2.
- "Christlicher und Rassen-Antisemitismus,"
in: *Reichspost* (Vienna), July 8, 1897, pp. 1–2.
- "Das Mikrophon berichtet," in: *Radio Wien* (Vienna), 9/34 (May 19, 1933), p. 2.
- "Das neue Heim der 'Reichspost,'"
in: *Reichspost* (Vienna), December 7, 1913, pp. 4–7.

- “Das neueste Ravag-Stückl,” in: *Arbeiter-Zeitung* (Vienna), May 14, 1933, p. 3.
- “Das Wunschkonzert der RAVAG: Johann Strauss hat gesiegt,”
in: *Radio Wien* (Vienna), 7/20 (February 13, 1931), p. 1.
- “Der entfesselte Radioreporter,”
in: *Radiowelt* (Vienna), 10/25 (June 17, 1933), p. 795.
- “Der grosse Heimwehraufmarsch,” in: *Die Stunde* (Vienna), May 16, 1933, p. 2.
- “Der Heimwehraufmarsch in Wien,”
in: *Neues Wiener Tagblatt* (Vienna), May 15, 1933, pp. 1–2.
- “Der Marsch durch Wien,” in: *Reichspost* (Vienna), May 15, 1933, p. 3.
- “Der Schutzbund aufgelöst,” in: *Arbeiter-Zeitung* (Vienna), April 1, 1933, p. 1.
- “Der Spiessrutenlauf von Starhembergs Völkerbund,”
in: *Deutschoesterreichische Tages-Zeitung* (Vienna), May 15, 1933, p. 1.
- “Der Streit Deutschland-Österreich geht weiter,”
in: *Neue Freie Presse* (Vienna), May 9, 1933 (evening edition), p. 2.
- “Der Wandel im Wiener Rathause,”
in: *Reichspost* (Vienna), February 14, 1934, p. 1.
- “Der Zug der Vierzigtausend durch Wien,”
in: *Reichspost* (Vienna), May 15, 1933, p. 1.
- “Des Feindes Wogen gebrochen an Starhemberg,”
in: *Wiener Mittagsblatt* (Vienna), May 15, 1933, pp. 3–4.
- “Die amtliche Wettervorhersage,”
in: *Neue Freie Presse* (Vienna), May 14, 1933 (morning edition), p. 14.
- “Die Ankunft der reichsdeutschen Nationalsozialisten,”
in: *Das Kleine Volksblatt* (Vienna), May 14, 1933, p. 4.
- “Die Antwort auf den Kikeriki-Sonntag,”
in: *Arbeiter-Zeitung* (Vienna), May 16, 1933, p. 2.
- “Die Arbeiterpresse unter Vorzensur,”
in: *Arbeiter-Zeitung* (Vienna), March 26, 1933, pp. 1–2.
- “Die Befreiung Wiens und die Gegenwart,”
in: *Neue Freie Presse* (Vienna), May 14, 1933 (morning edition), pp. 1–2.
- “Die Freiheitsfeiern in den Wiener Bezirken,”
in: *Arbeiter-Zeitung* (Vienna), May 15, 1933, p. 1.
- “Die Haydn-Melodie in den Schulen,”
in: *Neue Freie Presse* (Vienna), February 13, 1930 (morning edition), p. 7.
- “Die Heimreise Dr. Franks,”
in: *Neue Freie Presse* (Vienna), May 16, 1933 (evening edition), p. 2.
- “Die Hörerbefragung der Ravag,”
in: *Radio Wien* (Vienna), 9/6 (November 4, 1932), pp. 2–5.
- “Die nationalsozialistischen Fluggäste aus Deutschland,”
in: *Reichspost* (Vienna), May 14, 1933, p. 8.
- “Die nationalsozialistische Türkenbefreiungsfeier in der Engelmann-Arena,”
in: *Deutschoesterreichische Tages-Zeitung* (Vienna), May 16, 1933, p. 4.
- “Die neue deutschösterreichische Hymne,”
in: *Illustrierte Kronen-Zeitung* (Vienna), June 28, 1920, p. 2.
- “Die Ravag der ‘Gnädigen,’” in: *Das Kleine Blatt* (Vienna), May 16, 1933, p. 2.
- “Die Ravag mit dem Hahnenschwanz,”
in: *Das Kleine Blatt* (Vienna), May 16, 1933, p. 9.

- “Die Rede des Bundeskanzlers,”
in: *Reichspost* (Vienna), May 15, 1933, pp. 2–3.
- “Die Türkenbefreiungsfeier in Schönbrunn,”
in: *Reichspost* (Vienna), May 15, 1933, pp. 1–2.
- Dobesch, Karl: “Lautsprecher im Stephansdom,”
in: *Radiowelt* (Vienna), 9/20 (May 14, 1932), pp. 620–621.
- “Easter Sun Finds the Past in Shadow at Modern Parade,”
in: *The New York Times* (New York City), April 1, 1929, pp. 1 and 3.
- “Ein Wettbewerb für Stadtarchitektur,”
in: *Arbeiter-Zeitung* (Vienna), October 30, 1923, p. 6.
- “Empfangsabend auf der italienischen Gesandtschaft,”
in: *Neues Wiener Journal* (Vienna), April 23, 1933, p. 7.
- “Ernst Rüdiger Starhemberg einem Herzschlag erlegen,”
in: *Vorarlberger Nachrichten* (Bregenz), March 16, 1956, p. 1.
- “Ersuchen um Rückberufung Dr. Franks,”
in: *Reichspost* (Vienna), May 16, 1933, p. 1.
- Flynn, John T.: “Edward L. Bernays. The Science of Ballyhoo,”
in: *Atlantic Monthly* (Boston), 149/5 (May 1932), pp. 562–571.
- “Fort mit dem Parlament!,” in: *Österreichische Heimatschutzzeitung*
(Vienna), 2/8 (February 25, 1933), pp. 1–3.
- “Fox Tönende Wochenschau,” in: *Österreichische Film-Zeitung*
(Vienna), 7/20 (May 20, 1933), p. 6.
- Frühwald, Franz: “Rundfunkzahlen und ihre Wertung,”
in: *Radio-Amateur* (Vienna), 9/2 (February 1932), pp. 73–78.
- “Für wen sendet Radio-Wien?,” in: *Radiowelt* (Vienna), 5/17 (April 28, 1928), p. 1.
- “Galaabend im Burgtheater,” in: *Neues Wiener Journal*
(Vienna), April 23, 1933, p. 7.
- “Gesetz vom 3. April 1919 über die Aufhebung des Adels, der weltlichen
Ritter- und Damenorden und gewisser Titel und Würden,”
in: *Staatsgesetzblatt für den Staat Deutschösterreich* (StGBL),
71/211 (April 10, 1919), pp. 514–515.
- “Gründung einer Kurzwellenarbeitsgemeinschaft,”
in: *Die Rote Fahne* (Vienna), April 13, 1930, p. 8.
- “Heimatdienst im Rundfunk,”
in: *Radiowelt* (Vienna), 10/19 (May 6, 1933), p. 582.
- “Heimwehrkundgebungen am Sonntag,”
in: *Reichspost* (Vienna), May 19, 1930, p. 2.
- Herzog, Herta: “Stimme und Persönlichkeit,”
in: *Zeitschrift für Psychologie*, 130/3–5 (1933), pp. 300–369.
- “Heute Freiheitsfeiern,” in: *Arbeiter-Zeitung* (Vienna), May 14, 1933, p. 1.
- “Hinein in die vaterländische Front!,”
in: *Wiener Zeitung* (Vienna), May 21, 1933, p. 3.
- Hirsch, Johann: “Der Jazzsänger,”
in: *Das Kleine Blatt* (Vienna), January 25, 1929, p. 8.
- “Hörerbefragung,” in: *Radio Wien* (Vienna), 8/7 (November 13, 1931), p. 1.
- “Hymnenchaos,” in: *Neue Freie Presse* (Vienna),
February 14, 1930 (morning edition), pp. 1–2.

- “Inländische Begebenheiten,” in: *Wiener Zeitung* (Vienna), February 22, 1797, pp. 537–541.
- “‘Innsbrucker Empfang’ der Starhemberg-Heimwehr in Wien,” in: *Deutschösterreichische Tages-Zeitung* (Vienna), May 15, 1933, p. 2.
- “Italienische Waffen für Ungarn gehen über Österreich!,” in: *Arbeiter-Zeitung* (Vienna), January 8, 1933, p. 1.
- “Kein Aufmarschverbot für die Hahnenschwänzler!,” in: *Arbeiter-Zeitung* (Vienna), May 14, 1933, p. 3.
- “Kino-Programme,” in: *Die Stunde* (Vienna), May 13, 1933, p. 4.
- “Kino-Programme,” in: *Die Stunde* (Vienna), May 14, 1933, p. 4.
- “Klarstellungen zum deutschen Ministerbesuch,” in: *Reichspost* (Vienna), May 11, 1933, p. 3.
- Kleebinder, Bernhard: “Was sind Rundspruch-Kabelleitungen?,” in: *Radiowelt* (Vienna), 9/11 (March 12, 1932), pp. 338–340.
- Kobl Müller, Alfred: “Über Mikrophone und ihre Besprechungstechnik,” in: *Radiowelt* (Vienna), 8/45 (November 7, 1931), pp. 1458–1461.
- Kretschmayr, Heinrich: “Die historische Bedeutung der Befreiung Wiens,” in: *Das interessante Blatt* (Vienna), 52/22 (June 1, 1933), pp. 4–5.
- “Kündigung des Radioabonnements,” in: *Arbeiter-Zeitung* (Vienna), November 28, 1933, p. 7.
- “Lärmender Empfang der nationalsozialistischen Minister,” in: *Neue Freie Presse* (Vienna), May 14, 1933 (morning edition), p. 7.
- Lazarsfeld, Paul F.: “The Art of Asking Why in Marketing Research. Three Principles Underlying the Formulation of Questionnaires,” in: *National Marketing Review*, 1/1 (1935), pp. 26–38.
- Lazarsfeld, Paul F.: “The Psychological Aspect of Market Research,” in: *Harvard Business Review*, 13/1 (1934), pp. 54–71.
- Lazarsfeld, Paul: “Was erraten wir aus der menschlichen Stimme?,” in: *Radio Wien* (Vienna), 7/36 (June 5, 1931), pp. 9–11.
- Lazarsfeld, Paul: “Was erraten wir aus der menschlichen Stimme?,” in: *Radio Wien* (Vienna), 7/45 (August 7, 1931), pp. 4–5.
- “Lichtspiele,” in: *Deutschösterreichische Tages-Zeitung* (Vienna), May 13, 1933, p. 14.
- Loos, Adolf: “Wohnen lernen!,” in: *Neues Wiener Tagblatt* (Vienna), May 15, 1921, p. 8.
- Melville, Herman: “Bartleby, the Scrivener,” in: *Putnam’s Monthly Magazine of American Literature, Science, and Art* (New York), 2 (July–December 1853), pp. 546–557 and 609–615.
- “Österreichs staatliche Zukunft und die Sozialdemokratie,” in: *Arbeiter-Zeitung* (Vienna), May 13, 1933, p. 1.
- “Paramount-Tonwoche,” in: *Österreichische Film-Zeitung* (Vienna), 7/20 (May 20, 1933), p. 6.
- “Pfui-Rufe, rote Fahnen und Pfeifkonzert,” in: *Die Rote Fahne* (Vienna), May 14, 1933, p. 2.
- “Probesendungen am Bisamberg,” in: *Radiowelt* (Vienna), 10/19 (May 6, 1933), p. 582.
- Radermacher, Lotte: “Warum Hörer ihre Teilnehmerschaft aufgeben,” in: *Radio Wien* (Vienna), 7/47 (August 21, 1931), p. 3.

- “Radiodemokratie!,” in: *Arbeiter-Zeitung* (Vienna), March 12, 1924, pp. 1–2.
- “Radiofreiheit!,” in: *Radiowelt* (Vienna), 1/3 (March 23, 1924), pp. 1–2.
- “Radio-Wochenprogramm vom 22. bis 30. April,”
in: *Neue Freie Presse* (Vienna), April 22, 1933 (evening edition), p. 4.
- “Radio-Wochenprogramm vom 13. bis 21. Mai,”
in: *Neue Freie Presse* (Vienna), May 13, 1933 (evening edition), p. 4.
- Rakuschan, Ferdinand: “Die Andacht der Dreihunderttausend,”
in: *Radiowelt* (Vienna), 10/46 (November 11, 1933), pp. 1508–1509.
- “Reichsdeutscher Besuch bei den Nationalsozialisten,”
in: *Wiener Zeitung* (Vienna), May 14, 1933, p. 6.
- “Riesentriumph des Heimatschutzes!,”
in: *Wiener Mittagsblatt* (Vienna), May 15, 1933, p. 2.
- Robinson, Frederic H.: “The Hearty Breakfast Wins,”
in: *Medical Review of Reviews*, 28/11 (November 1922), pp. 503–508.
- Rosenfeld, Fritz: “Der Jazzsänger,”
in: *Arbeiter-Zeitung* (Vienna), January 23, 1929, p. 6.
- Rosenfeld, Fritz: “Die Front des Friedens,”
in: *Arbeiter-Zeitung* (Vienna), April 4, 1930, p. 8.
- Rosenfeld, Fritz: “Die Herrschaft des Verbrechens,”
in: *Arbeiter-Zeitung* (Vienna), May 14, 1933, p. 17.
- “Ruhiger Verlauf des Tages zu erwarten,”
in: *Neue Freie Presse* (Vienna), May 13, 1933 (morning edition), pp. 1–2.
- “Rundfunksendungen auf Tonstreifen,”
in: *Radio Wien* (Vienna), 13/13 (December 25, 1936), pp. 2–3.
- Rundt, Arthur: “Humbug, Bluff und Ballyhoo. Von Barnum bis Bernays,”
in: *Der Querschnitt* (Berlin), 13/4 (April 1933), pp. 265–269.
- Rundt, Arthur: “Humbug, Bluff und Ballyhoo. Von Barnum bis Bernays,” in:
Neue Freie Presse (Vienna), May 14, 1933 (morning edition), pp. 25–26.
- Schiller, Friedrich: “An die Freude,” in: *Thalia* (Leipzig), 1/2 (1786), pp. 1–5.
- Schwaiger, Gustav: “Die Bedeutung der Kurzwellen für den Rundfunk,”
in: *Radiowelt* (Vienna), 9/23 (June 4, 1932), pp. 710 and 735.
- Schwaiger, Gustav: “Technischer Rück- und Ausblick,”
in: *Radio Wien* (Vienna), 11/1 (September 28, 1934), pp. 19–25.
- “Sei gesegnet ohne Ende!,” in: *Reichspost* (Vienna), December 22, 1929, p. 4.
- “Sie haben gesprochen!,” in: *Radiowelt* (Vienna), 2/19 (May 9, 1925), pp. 1–2.
- “Sonntag, 14. Mai,” in: *Radio Wien* (Vienna), 9/33 (May 12, 1933), pp. 31–38.
- “Staatsvertrag von Saint-Germain-en-Laye vom 10. September 1919,”
in: *Staatsgesetzblatt für die Republik Österreich* (StGBL),
90/303 (July 21, 1920), pp. 995–1245.
- “Starhemberg beglückwünscht siegreichen Fascismus,”
in: *Der Heimatschützer* (Vienna), 4/20 (May 16, 1936), p. 3.
- “Tausende Radiohörer kündigen das Abonnement,”
in: *Arbeiter-Zeitung* (Vienna), April 20, 1933, p. 1.
- “Telegramm des Unterrichtsministers Dr. Rintelen an den Duce,”
in: *Neues Wiener Journal* (Vienna), April 23, 1933, p. 7.
- “Theater,” in: *Neue Freie Presse* (Vienna), May 13, 1933 (morning edition), p. 16.
- “Triumphzug durch die Strassen,” in: *Deutschösterreichische Tages-Zeitung* (Vienna), May 14, 1933, p. 3.

- “Überwältigende Feier in der Engelmann-Arena,” in:
Deutschösterreichische Tages-Zeitung (Vienna), May 14, 1933, p. 2.
- “Überwältigende Trauerkundgebung auf dem Heldenplatz,”
 in: *Reichspost* (Vienna), August 9, 1934, p. 1.
- “Unerwünschter Besuch,” in: *Arbeiter-Zeitung* (Vienna), May 10, 1933, p. 3.
- “Unerwünschter Besuch,” in: *Reichspost* (Vienna), May 9, 1933, pp. 1–2.
- “Unser Weg ist der einzig richtige!,”
 in: *Wiener Mittagsblatt* (Vienna), May 15, 1933, pp. 4–5.
- “Volkshymne,” in: *Wiener Zeitung* (Vienna), April 9, 1854, p. 2.
- “Vorträge und Führungen der BEST im Jänner und Februar 1931,”
 in: *Die Wohnungsreform* (Vienna), 2/1 (January 1931), p. 7.
- Wagner, Gertrud: “Die Programmwünsche der österreichischen Radiohörer,”
 in: *Archiv für die gesamte Psychologie*, 90 (1934), pp. 157–164.
- “Was gibt’s Neues im Äther?,”
 in: *Radiowelt* (Vienna), 10/14 (April 1, 1933), p. 423.
- “Was jetzt? Rundfunkrede des Bundeskanzlers,”
 in: *Reichspost* (Vienna), March 14, 1933, p. 5.
- “Was wünschen Sie zu hören?,”
 in: *Radiowelt* (Vienna), 1/41 (December 13, 1924), p. 7.
- “Was zahlt der Radiohörer?,”
 in: *Radiowelt* (Vienna), 9/3 (January 16, 1932), pp. 1–2.
- “Weder Hitler noch Habsburg!,”
 in: *Arbeiter-Zeitung* (Vienna), May 13, 1933, pp. 1–2.
- “Wesen und Arbeitsmethoden des Sowjetfilms,”
 in: *Die Rote Fahne* (Vienna), February 9, 1930, p. 7.
- “Wie die Tonfilmwochenschau entsteht,”
 in: *Mikrophon* (Vienna), 1/1 (February 1934), pp. 47–49.
- “Wir Heimatschützer decken den Bundeskanzler!,”
 in: *Reichspost* (Vienna), May 15, 1933, p. 2.
- “Wir kämpfen für die Freiheit,” in: *Das Kleine Blatt* (Vienna), May 14, 1933, p. 2.
- “Wir sind unbesiegbar!,” in: *Wiener Mittagsblatt* (Vienna), May 15, 1933, p. 4.
- “Zwei Feste der Wiener Gemeindeverwaltung,”
 in: *Arbeiter-Zeitung* (Vienna), October 4, 1926, p. 3.

Secondary Literature

- Bauer, Jean: “Who You Calling Untheoretical?,” in: *Journal of Digital Humanities*, 1/1 (2011), URL: journalofdigitalhumanities.org/1-1/who-you-calling-untheoretical-by-jean-bauer
- Beverungen, Armin and Stephen Dunne: “‘I’d prefer not to.’
 Bartleby and the Excesses of Interpretation,” in: *Culture and Organization*, 12/2 (2007), pp. 171–183.
- Bitterauh, Theodor: “Friedrich Stepss und das Schönbrunner Attentat auf Napoleon I.,” in: *Die Grenzboten* (Berlin), 69/3 (1910), pp. 212–220.
- Borkowsky, Ernst: “Das Schönbrunner Attentat im Jahr 1809 nach unveröffentlichten Quellen,” in: *Die Grenzboten* (Leipzig), 57/4 (1898), pp. 293–301.

- Bussemer, Thymian: "Paul Felix Lazarsfeld und die Etablierung der Kommunikationsforschung als empirische Sozialwissenschaft," in: *Medien & Kommunikationswissenschaft*, 55/1 (2007), pp. 80–100.
- Crampton, Jeremy W. and John Krygier: "An Introduction to Critical Cartography," in: *ACME. An International E-Journal for Critical Geographies*, 4/1 (2005), pp. 11–33, URL: www.acme-journal.org/index.php/acme/article/view/723
- Downie, J.A. and Thomas N. Corns (eds.): "Telling People What to Think. Early Eighteenth-Century Periodicals from *The Review* to *The Rambler*," in: *Prose Studies*, 16/1 (1993).
- Fisher, Lucy: "Dr. Mabuse and Mr. Lang," in: *Wide Angle*, 3/3 (1979), pp. 18–26.
- Fullerton, Ron: "The Beginnings of Motivation Research, 1934–1954. A Prequel to Fullerton 2013," in: *Journal of Historical Research in Marketing*, 7/4 (2015), pp. 509–523.
- Ganahl, Simon: "Der monströse Fouleuze. Eine philosophische Lektüre von Andrej Belyjs *Petersburg*," in: *Le foucauldien*, 3/1 (2017), DOI: doi.org/10.16995/lefou.23
- Hadamowsky, Franz: "Die Schauspielerei, die 'Erhebung des Burgtheaters zum Hoftheater' und seine 'Begründung als Nationaltheater' im Jahr 1776," in: *Maske und Kothurn*, 22/1–2 (1976), pp. 5–19.
- Haraway, Donna: "Situated Knowledges. The Science Question in Feminism and the Privilege of Partial Perspective," in: *Feminist Studies*, 14/3 (1988), pp. 575–599.
- Henz, Rudolf: "Der März 1938. Die letzten Tage der RAVAG. Ein Dokument," in: *morgen – Kulturzeitschrift aus Niederösterreich*, 2/3 (1978), pp. 29–32.
- Kleespies, Ingrid: "Riding the *Soviet Iron Horse*. A Reading of Viktor Turin's *Turksib* through the Lens of John Ford," in: *Slavic Review*, 77/2 (2018), pp. 358–389.
- Lazarsfeld, Paul F.: "Notes on the History of Quantification in Sociology. Trends, Sources and Problems," in: *Isis*, 52/2 (1961), pp. 277–333.
- Longman, Stanley V.: "Mussolini and the Theatre," in: *Quarterly Journal of Speech*, 60/2 (1974), pp. 212–224.
- Merton, Robert K.: "The Focused Interview and Focus Groups. Continuities and Discontinuities," in: *Public Opinion Quarterly*, 51/4 (1987), pp. 550–566.
- Miller, Rotraut: "Die Hofreisen Kaiser Leopolds I.," in: *Mitteilungen des Instituts für Österreichische Geschichtsforschung*, 75/1–2 (1967), pp. 66–103.
- Murphree, Vanessa: "Edward Bernays's 1929 'Torches of Freedom' March. Myths and Historical Significance," in: *American Journalism*, 32/3 (2015), pp. 258–281.
- Payne, Matthew J.: "Viktor Turin's 'Turksib' (1929) and Soviet Orientalism," in: *Historical Journal of Film, Radio and Television*, 21/1 (2001), pp. 37–62.
- Totzeva, Sophia: "Der Festspielzyklus 'Stimmen der Völker im Drama' (1932–1938). Übersetzungs- und Theaterpraxis im Spannungsfeld von Politik und Ideologie," in: *Maske und Kothurn*, 42/2–4 (1996), pp. 77–103.
- Venus, Theodor: "'Der Sender sei die Kanzel des Volkes.' Zur sozialdemokratischen Rundfunkpolitik in der 1. Republik," in: *Medien-Journal*, 7/1 (1983), pp. 8–19.

2.4 Films and Sound Recordings

- Crosland, Alan: *The Jazz Singer*, DVD, Hamburg: Warner Home Video 2007 [1927].
- Deutschland erwacht*, 35 mm film, Berlin: NSDAP 1933, Film Archive of the Federal Archives (Berlin), K 125719-6.
- “Die Arbeiter von Wien,” DAT cassette, Österreichische Mediathek, 11-00983_b02.
- “Die Türkenbefreiungs-Feier des österreichischen Heimatschutzes am 14. Mai 1933 im Schloss Schönbrunn,” in: *Jahresschau 1933 der Bundespolizeidirektion in Wien. Eine Chronik im Laufbild*, 35 mm film, Filmarchiv Austria, JS 1933/8.
- “Die Türkenbefreiungsfeier des österreichischen Heimatschutzes in Wien,” in: *Jahresschau 1933 der Bundespolizeidirektion in Wien. Eine Chronik im Laufbild*, 35 mm film, Filmarchiv Austria, JS 1933/8.
- Eisenstein, Sergej and Edmund Meisel: *Panzerkreuzer Potemkin* [1926/1930] & *Oktjabr*, DVD 1, Munich: Edition Filmmuseum 2014.
- “Engelbert Dollfuß anlässlich einer Feier zur Erinnerung an die Befreiung Wiens von den Türken” (Vienna, May 14, 1933), CD, Österreichische Mediathek, 8-29501_b02.
- Gervasi, Sacha: *Hitchcock*, DVD, Frankfurt a.M.: Twentieth Century Fox 2013 [2012].
- Hitchcock, Alfred: *Psycho*, DVD, Universal City: Universal Studios 1999 [1960].
- Lang, Fritz: *Das Testament des Dr. Mabuse*, 35 mm film, Berlin: Nero Film AG 1933, Film Archive of the Federal Archives (Berlin), BSP 26989-12.
- “Letzte Rundfunkansprache als Österreichischer Bundeskanzler von Kurt Schuschnigg am 11. März 1938,” audiotape (AEG), Österreichische Mediathek, 99-38002_k02.
- “NSDAP-Kundgebung zum 1. Mai 1933 in der Wiener Engelmann-Arena,” in: Hannes Leidinger and Karin Moser (eds.): *Österreich Box 2: 1918–1938. Zwischen den Weltkriegen*, DVD, Vienna: Filmarchiv Austria 2008.
- N.S. Ton-Bild-Bericht Nr. 2*, 35 mm film, Berlin: NSDAP 1933, Film Archive of the Federal Archives (Berlin), K 20317-2.
- Turin, Viktor: *Turksib* [1929/1930], in: *The Soviet Influence. From Turksib to Night Mail*, DVD, London: BFI 2011.

2.5 Websites

- Austrian Newspapers Online*, URL: anno.onb.ac.at
- Creative Commons Attribution 4.0 International*, URL: creativecommons.org/licenses/by/4.0/deed.en
- Dallinger, Silvia: “Katholikentag & Staatliche Türkenbefreiungsfeier 1933,” in: Johannes Feichtinger and Johann Heiss (eds.): *Türkengedächtnis* (2010), URL: www.oeaw.ac.at/tuerkengedaechtnis/home/feiern/250-jaehriges-jubilaeum-1933/katholikentag-staatliche-tuerkenbefreiungsfeier
- “Das Testament des Dr. Mabuse,” in: *filmportal.de*, URL: www.filmportal.de/film/das-testament-des-dr-mabuse_2ab1c65e6aed44dfac401ad99147182d

Ganahl, Simon et al.: *Campus Medius*, 2014–2021, URL: campusmedius.net
 Hadler, Simon: “Stephansdom, Mondschein,” in: Johannes Feichtinger and Johann Heiss (eds.): *Türkengedächtnis* (2010), URL: www.oeaw.ac.at/tuerkengedaechtnis/home/denkmaeler/ort/stephansdom-mondschein
JSON for Linking Data, URL: json-ld.org
Karl Kraus 1933, URL: kraus1933.ace.oeaw.ac.at
 Krimbacher, Andreas: “Campus Medius,” 2021, in: *GitHub*, URL: github.com/campusmedius/campusmedius
OpenStreetMap, URL: www.openstreetmap.org
PHAIDRA, URL: phaidra.univie.ac.at
 Presner, Todd et al.: *HyperCities*, URL: www.hypercities.com
Schema.org, URL: schema.org
 Schnapp, Jeffrey et al.: *The Digital Humanities Manifesto 2.0*, 2009, URL: www.humanitiesblast.com/manifesto/Manifesto_V2.pdf

3. Project Team

3.1 Project Head

Simon Ganahl heads the project *Campus Medius* and wrote all the texts of the website campusmedius.net and of this book edition. He researches and teaches as a literature and media scholar with a focus on digital humanities at the Universities of Vienna, Zurich, Liechtenstein, and Vorarlberg. After studies in liberal arts and social sciences in Vienna, Hamburg, and Zurich, he obtained PhD degrees in communication science (2009) and in German philology (2012) at the University of Vienna. In 2012/13 he was a visiting researcher in the School of Media Studies at The New School in New York and in 2016 a visiting lecturer in the Center for Digital Humanities at the University of California, Los Angeles (UCLA). He is also cofounder and managing editor of the peer-reviewed, open-access journal *Genealogy+Critique*, published by the Open Library of Humanities (London). His research work has received several awards and grants (e.g., APART from the Austrian Academy of Sciences and Schrödinger from the Austrian Science Fund). Selected publications: *Campus Medius: Digital Mapping in Cultural and Media Studies* (2022); *Karl Kraus-Handbuch: Leben – Werk – Wirkung* (ed. with Katharina Prager, 2022); *Karl Kraus und Peter Altenberg: Eine Typologie moderner Haltungen* (2015).

3.2 Software Development

I.1 *Darius Daftary* programmed the front end of **Campus Medius 1.0** (2014) in AngularJS and Leaflet. He has many years of experience as a leading software engineer in New York’s digital economy and also teaches web development at university level. He studied Spanish at Washington University in St. Louis.

I.2 *Andreas Krimbacher* developed the software for **Campus Medius 2.0** (2021). He employed only open-source technologies and has made the project code available under the MIT license at GitHub (URL: github.com/campusmedius/campusmedius). The website’s front end was programmed in Angular and Mapbox GL JS, the back end in Django using a PostgreSQL database. He studied geomatics engineering at the University of Graz (BA, 2012) and the ETH Zurich (MSc, 2014). Since 2015 he has been working at the Austrian Zentralanstalt für Meteorologie und Geodynamik (ZAMG) as a software developer and system architect. Since 2020 he has also been tech lead (CTO) of the start-up company nexyo (URL: nexyo.io).

I.1 *Rory Solomon* developed **Campus Medius 1.0** (2014) together with Simon Ganahl and programmed the back end of this initial version of the website in Django using a PostgreSQL database. He is director of the “Code as a Liberal Art” program at Eugene Lang College and assistant professor in the Department of Culture & Media at The New School in New York. He studied computer science and mathematics (BA) at UC Berkeley, as well as media studies (MA) at The New School, and earned his PhD in the Department of Media, Culture, and Communication at New York University.

3.3 Design

Stefan Amann designed this book edition of *Campus Medius*. After training as a merchant, he studied communication design at Vorarlberg University of Applied Sciences (FH) and Manchester Metropolitan University and worked as a marketing consultant, copywriter, and graphic designer. In 2004, he founded the design agency proxi (URL: proxi.me) with offices

in Austria, Spain, and Germany, which he has co-owned and co-led since then. Apart from his design work, focusing on editorial and spatial design, he teaches in the InterMedia program at FH Vorarlberg.

- I.1 *Mallory Brennan* designed the website of **Campus Medius 1.0** (2014). She studied communication design (BFA) and media studies (MA) at The New School and works as a media designer in New York City.
- I.2 *Susanne Kiesenhofer* designed the website of **Campus Medius 2.0** (2021). She studied media technology at St. Pölten University of Applied Sciences (BSc, 2012) and media design at Vorarlberg University of Applied Sciences (MA, 2016). From 2017 to 2020 she was employed at the innovation lab of the communication agency Milla & Partner in Stuttgart. Since 2020 she has been working at the Ars Electronica Futurelab in Linz.

3.4 Translations

- I.1 *Katy Derbyshire* translated the texts of **Campus Medius 1.0** (2014) from German into English. She grew up in London, where she studied translation and German. Since 1996 she has been living in Berlin as a translator of contemporary German literature (among others by Clemens Meyer, Inka Parei, and Christa Wolf).
- III *Maria Slater* translated the **Topology module** from German into English and copy-edited all other English-language texts of **Campus Medius 2.0** (2021) and of this book edition. Based in Vienna since 2009, she has many years of experience as a translator and copy editor of publications and a wide range of texts in the fields of art & culture and research & academia. She studied modern and medieval languages (French and German, MA Cantab) at the University of Cambridge and German philology (MA) at the University of Vienna.

3.5 Advisory Board

Roland Innerhofer is emeritus professor of modern German literature at the University of Vienna. Among his research foci are the history of Austrian literature and culture, science fiction, media aesthetics, the theory of literary genres, and the poetics of knowledge. He is the main editor of a digital edition of Andreas Okopenko's diaries (URL: edition.onb.ac.at/okopenko). His monographs include: *Architektur aus Sprache: Korrespondenzen zwischen Literatur und Baukunst 1890–1930* (2018); *Deutsche Science Fiction 1870–1914: Rekonstruktion und Analyse der Anfänge einer Gattung* (1996).

Colin Koopman is head of the philosophy department and director of the New Media & Culture graduate certificate program at the University of Oregon. His work mobilizes analytics and concepts from the philosophical traditions of genealogy and pragmatism to engage current issues of politics, ethics, and culture. He has published three monographs: *How We Became Our Data: A Genealogy of the Informational Person* (2019); *Genealogy as Critique: Foucault and the Problems of Modernity* (2013); *Pragmatism as Transition: Historicity and Hope in James, Dewey, and Rorty* (2009).

Shannon Mattern is professor in the Department of Anthropology at The New School in New York. Her research and teaching addresses, among other subjects, media infrastructures, the materiality of media objects, urban media history, and media architecture, especially libraries and archives. She is the author of the following monographs: *A City Is Not a Computer: Other Urban Intelligences* (2021); *Code and Clay, Data and Dirt: Five Thousand Years of Urban Media* (2017); *Deep Mapping the Media City* (2015); *The New Downtown Library: Designing with Communities* (2006).

Todd Presner is chair of the Department of European Languages and Transcultural Studies at the University of California, Los Angeles (UCLA), from 2011 to 2021 he was the director of UCLA's Digital Humanities program. His research focuses on European intellectual history, the history of media, visual

culture, digital humanities, and cultural geography. From 2005 to 2015, he headed *HyperCities*, a collaborative, digital mapping platform that explored the layered histories of city spaces. He is the author or editor of several books, among them *Urban Humanities: New Practices for Reimagining the City* (ed. et al., 2020), *HyperCities: Thick Mapping in the Digital Humanities* (coauthored with David Shepard and Yoh Kawano, 2014), *Digital Humanities* (ed. et al., 2012), and *Mobile Modernity: Germans, Jews, Trains* (2007).

Philipp Sarasin is professor of modern history at the University of Zurich and coeditor of the online journal *Geschichte der Gegenwart*. His research mainly deals with the history of knowledge, theories of historiography, urban history, and the history of sexuality and the human body. His key publications are: *1977: Eine kurze Geschichte der Gegenwart* (2021); *Michel Foucault zur Einführung* (7th ed., 2020); *Darwin und Foucault: Genealogie und Geschichte im Zeitalter der Biologie* (2009); *Anthrax: Bioterror as Fact and Fantasy* (2006); *Geschichtswissenschaft und Diskursanalyse* (2003); *Reizbare Maschinen: Eine Geschichte des Körpers 1765–1914* (2001).